

付属品関係/Accessories

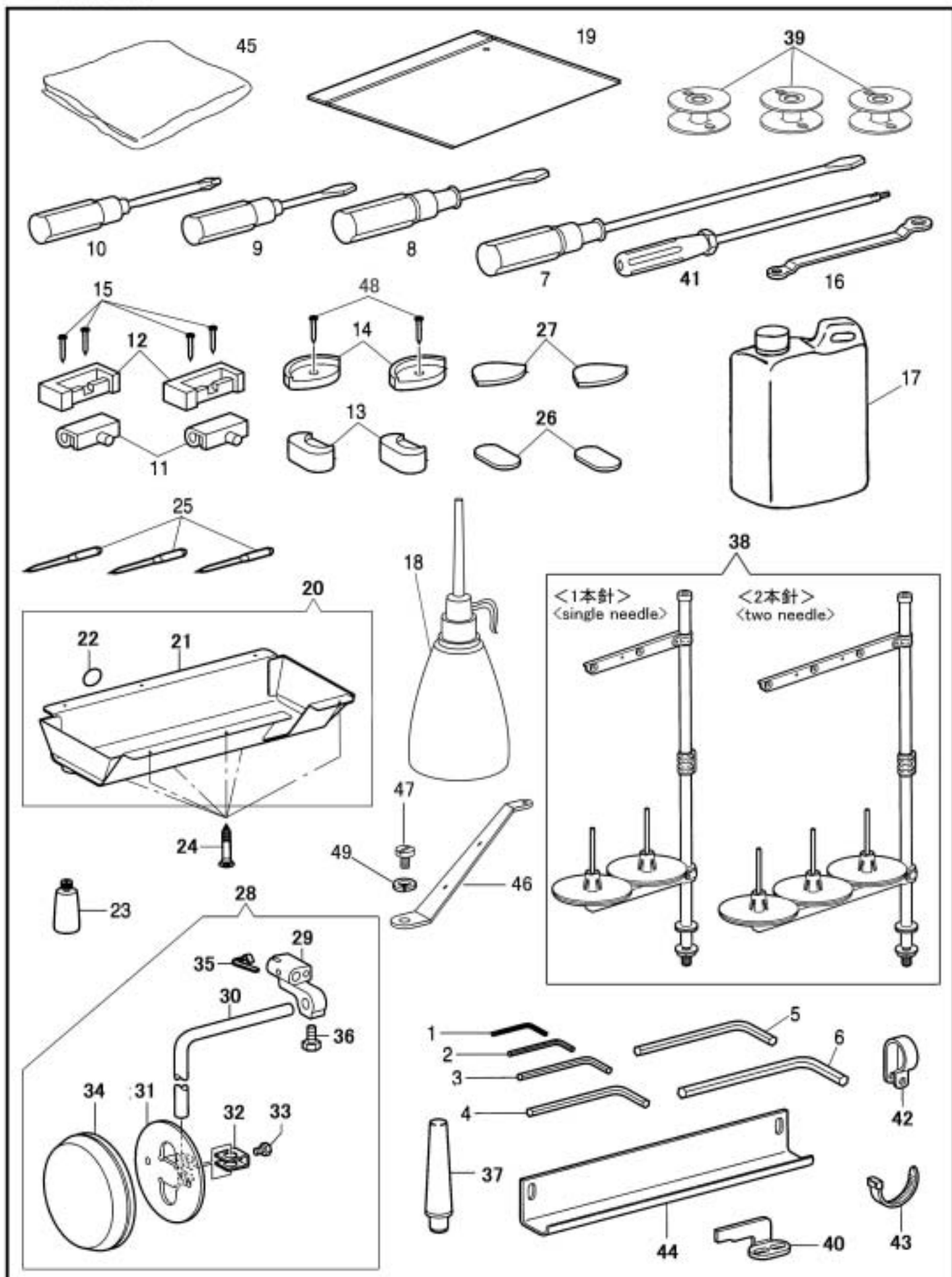

付属品関係/Accessories

NO.	部品番号 PARTS NO.	-8BL	-28BL	-8BLC	-28BLC	-8BLC- BTFL-CD-DS	-28BLC- BTFL-CD-DS	数量	品名	DESCRIPTION
								QTY		
1	1872	*	*	*	*	*	*	1	六角レンチ(1.5MM)	HEXAGONAL WRENCH, 1.5
2	19456	*	*	*	*	*	*	1	六角レンチ(2MM)	HEXAGONAL WRENCH, 2
3	19457	*	*	*	*	*	*	1	六角レンチ(2.5MM)	HEXAGONAL WRENCH, 2.5
4	19458-A	*	*	*	*	*	*	1	六角レンチ(3MM)	HEXAGONAL WRENCH, 3
5	19459	*	*	*	*	*	*	1	六角レンチ(4MM)	HEXAGONAL WRENCH, 4
6	19460	*	*	*	*	*	*	1	六角レンチ(5MM)	HEXAGONAL WRENCH, 5
7	8118	*	*	*	*	*	*	1	ドライバー(大)	SCREW DRIVER, L
8	8120	*	*	*	*	*	*	1	ドライバー(中)	SCREW DRIVER, M
9	8121	*	*	*	*	*	*	1	ドライバー(小)	SCREW DRIVER, S
10	19473	*	*	*	*	*	*	1	十字ドライバー	SCREW DRIVER, PLUS
11	11885	*	*	*	*	*	*	2	ヒンジ	HINGE
12	B143910	*	*	*	*	*	*	2	ヒンジ受けゴム	RUBBER CUSHION
13	BS53188	*	*	*	*	*	*	2	コーナー受け(B)	CORNER SUPPORT
14	B148890	*	*	*	*	*	*	2	コーナー受け(A)	HEAD CUSHION
15	6055	*	*	*	*	*	*	4	ヒンジ受け止釘	NAIL
16	19462	*	*	*	*	*	*	1	メガネレンチ	DOUBLE WRENCH
17	11193	*	*	*	*	*	*	1	オイルタンク	OIL TANK
18	8125	*	*	*	*	*	*	1	油差し	OILER
19	8132-A	*	*	*	*	*	*	1	部品袋	ACCESSORY BAG
20	60386C	*	*	*	*	*	*	1	油受け(組)	OIL PAN ASSY
21	60386	*	*	*	*	*	*	1	油受け	OIL PAN
22	PL-09	*	*	*	*	*	*	1	アースラベル	LABEL, GROUNDING
23	15082	*	*	*	*	*	*	1	油びん	POLY OILER
24	15081	*	*	*	*	*	*	6	油受け取付けねじ	WOOD SCREW
25	N0122	*	-	*	-	*	-	3	針 DPx17 #22	NEEDLE DPX17 (#22)
25	N0122	-	*	-	*	-	*	4	針 DPx17 #22	NEEDLE DPX17 (#22)
26	BS53190	*	*	*	*	*	*	2	頭部敷ゴム間座	SPACER, C-SUPPORT
27	BS53189	*	*	*	*	*	*	2	コーナー受けゴム間座	SPACER, H-CUSHION
28	60478C	*	*	*	*	-	-	1	膝当て(組)	KNEE LIFTER ASSY
29	60478	*	*	*	*	-	-	1	膝上げ継手	BRACKET, KNEE LIFTER
30	B104619	*	*	*	*	-	-	1	膝上げ立て軸	KNEE LIFTER BAR
31	BS34756	*	*	*	*	-	-	1	膝当て	KNEE LIFTER PLATE
32	B114967	*	*	*	*	-	-	1	膝当てストッパー	STOPPER, ;K-LIFTER PLATE
33	B110087	*	*	*	*	-	-	1	膝当て止	BOLT, SM5.95X28 L=8
34	BS31885	*	*	*	*	-	-	1	膝当てカバー	COVER, ;K-LIFTER PLATE
35	BS25783	*	*	*	*	-	-	1	膝上げ継手ばね	SPRING
36	B017081	*	*	*	*	-	-	1	膝上げ継手固定ねじ	BOLT, M8X1.25 L=16
37	B100477	*	*	*	*	*	*	1	頭部受け棒	HEAD REST
38	35254	*	-	*	-	*	-	1	糸立セット	THREAD STAND ASSY
38	10947	-	*	-	*	-	*	1	糸立セット	THREAD STAND ASSY
39	60536	*	-	*	-	*	-	3	ボビン	BOBBIN
39	60536	-	*	-	*	-	*	4	ボビン	BOBBIN
40	60302	-	-	*	-	*	-	1	固定メス	FIXED KNIFE
40	60302	-	-	-	*	-	*	2	固定メス	FIXED KNIFE
41	60699	-	*	-	*	-	*	1	六角棒ねじ回し	SCREW DRIVER, HEXAGONAL 2.5
42	30625	-	-	*	*	*	*	1	クッションクランプ	CUSHION CLAMP
43	60374	-	-	*	*	*	*	1	結束バンド	CABLE TIE
44	60012	-	-	-	-	*	*	1	コードカバー	CORD COVER
45	8124	*	*	*	*	*	*	1	マシンカバー	MACHINE COVER
46	38264	-	-	*	-	*	-	1	アーム糸掛け	THREAD GUIDE
46	38264	-	-	-	*	-	*	2	アーム糸掛け	THREAD GUIDE
47	30601	-	-	*	*	*	*	1	アーム糸掛け止めねじ	SCREW M5X0.8 L=10
48	6055	*	*	*	*	*	*	2	コーナー受け(A)止釘	NAIL
49	90625	-	-	*	-	*	-	1	スプリングワッシャー	SPRING WASHER
49	90625	-	-	-	*	-	*	2	スプリングワッシャー	SPRING WASHER