

糸調子関係/Tread tension

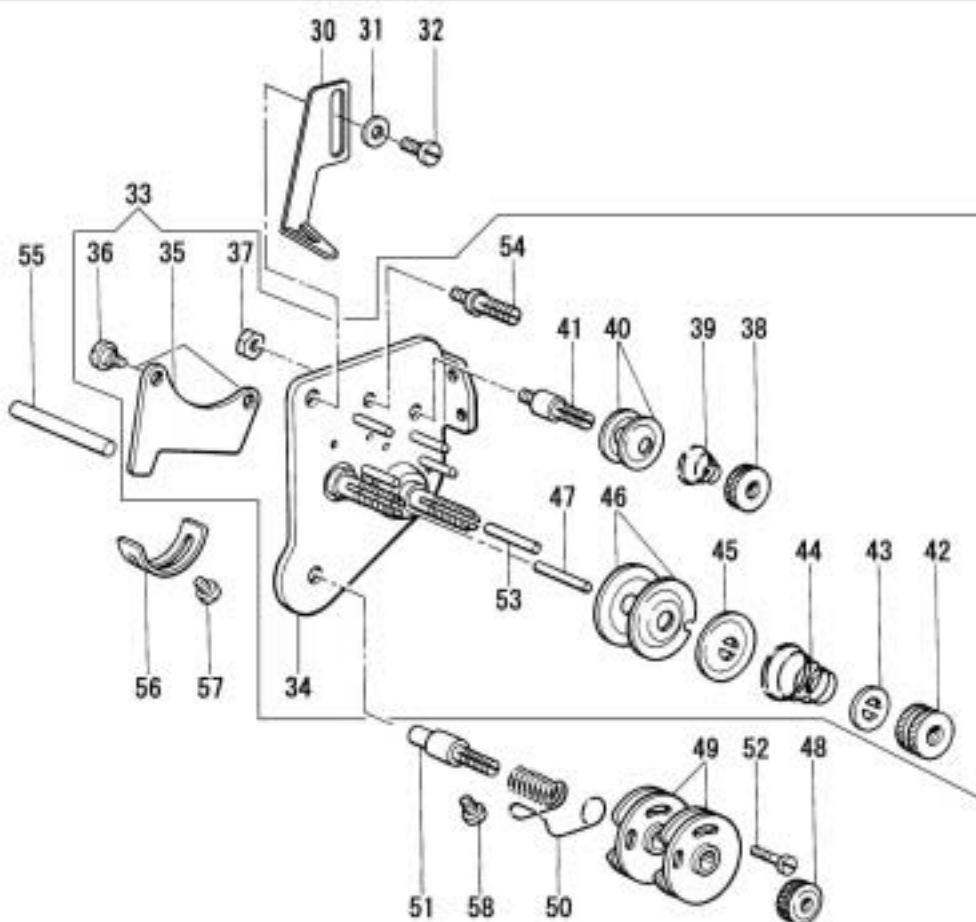
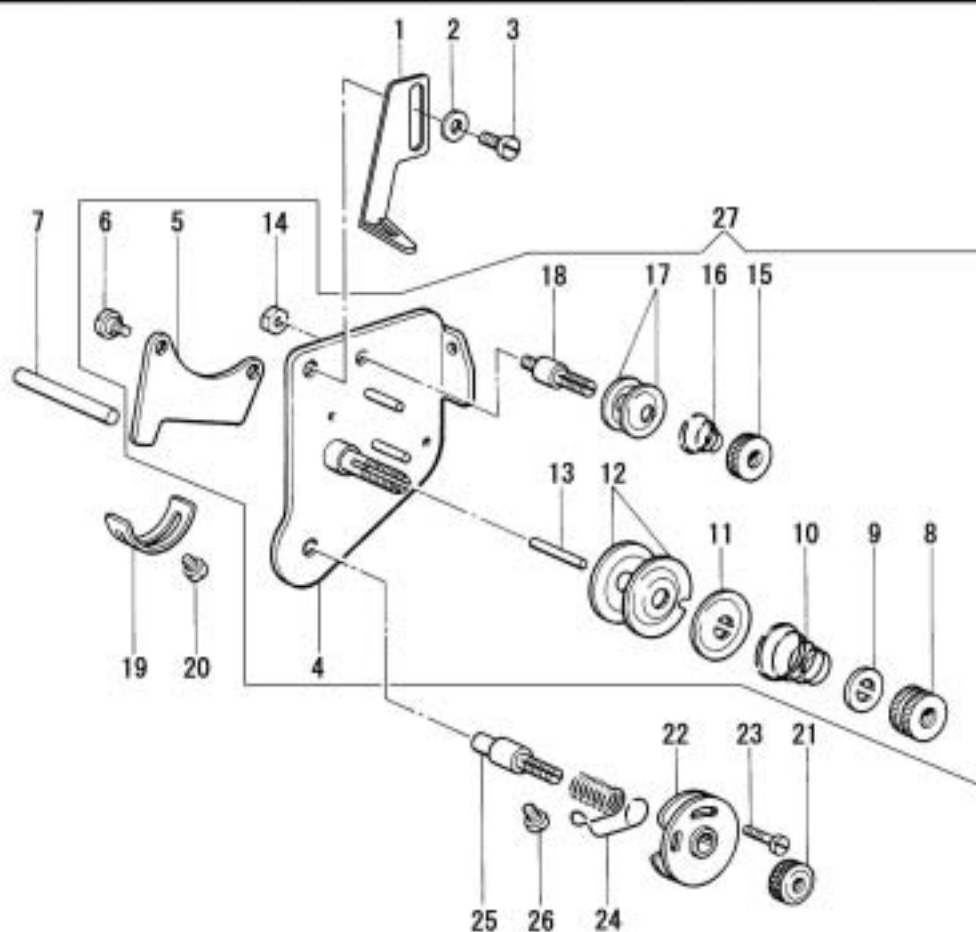

糸調子関係/Thread tension

	部品番号	8GW-1	8GWC-1	8GWC-1-ONU	22GW-1	数量	品名	DESCRIPTION
	PARTS					QTY		
1	37275	*	-	-	-	1	糸調子系掛け	THREAD GUIDE
2	33139	*	-	-	-	1	座金	WASHER
3	33141	*	-	-	-	1	止めねじ	SCREW SM11/64X32 L=9
4	33104	*	-	-	-	1	調子板	TENSION PLATE
5	10678	*	-	-	-	1	糸緩め板	TENSION RELEASE PLATE
6	10679	*	-	-	-	2	段ねじ	STUD SCREW 3.4X36
7	37278	*	-	-	-	1	糸緩めピン	TENSION RELEASE PIN
8	33105	*	-	-	-	1	ローレットナット	NUT
9	28206	*	-	-	-	1	ローレットストッパー	STOPPER
10	33135	*	-	-	-	1	糸調子ばね	TENSION SPRING
11	33151	*	-	-	-	1	丸一皿	TENSION DISC WASHER
12	33150	*	-	-	-	2	調子皿	TENSION DISC
13	10793	*	-	-	-	1	糸緩め段ピン	PIN
14	10652	*	-	-	-	1	ナット	NUT
15	33155	*	-	-	-	1	第一調子ローレット	TENSION THUMB NUT
16	33156	*	-	-	-	1	第一調子棒スプリング	SPRING
17	20224	*	-	-	-	2	第一調子皿	TENSION DISC
18	33160	*	-	-	-	1	第一調子棒(A)	TENSION STUD
19	10690	*	-	-	-	1	スプリング受け	SPRING STOPPER
20	33134	*	-	-	-	1	止めねじ	SET SCREW SM9/64X40 L=6
21	19534	*	-	-	-	1	ローレットナット	NUT
22	10694	*	-	-	-	1	二重皿	THREAD CONTROLLER
23	33136	*	-	-	-	1	止めねじ	SET SCREW SM3/32X80 L=6.5
24	10689	*	-	-	-	1	糸引きスプリング	SPRING
25	33149	*	-	-	-	1	糸調子棒	TENSION STUD
26	10545	*	-	-	-	1	止めねじ	SET SCREW SM11/64X32 L=14
27	33104C	*	-	-	-	1	調子板 (組)	TENSION PLATE COMPLETE
30	37275	-	-	-	*	1	糸調子系掛け	THREAD GUIDE
31	33139	-	-	-	*	1	座金	WASHER
32	33140	-	-	-	*	1	止めねじ	SCREW SM11/64X32 L=9
33	33510C	-	-	-	*	1	調子板 (組)	TENSION PLATE COMPLETE
34	33510	-	-	-	*	1	調子板	TENSION PLATE
35	10678	-	-	-	*	1	糸緩め板	TENSION RELEASE PLATE
36	10679	-	-	-	*	2	段ねじ	STUD SCREW 3.4X36
37	10652	-	-	-	*	1	ナット	NUT
38	33155	-	-	-	*	2	第一調子ローレット	TENSION THUMB NUT
39	33156	-	-	-	*	2	第一調子棒スプリング	SPRING
40	20224	-	-	-	*	4	第一調子皿	TENSION DISC
41	33501	-	-	-	*	1	第一調子棒 (B)	TENSION STUD
42	33105	-	-	-	*	2	ローレットナット	NUT
43	28206	-	-	-	*	2	ローレットストッパー	STOPPER
44	33135	-	-	-	*	2	糸調子ばね	TENSION SPRING
45	33151	-	-	-	*	2	丸一皿	TENSION DISC WASHER
46	33150	-	-	-	*	4	調子皿	TENSION DISC
47	10957	-	-	-	*	2	糸緩め段ピン (短)	PIN (SHORT)
48	19534	-	-	-	*	1	ローレットナット	NUT
49	10694	-	-	-	*	2	二重皿	THREAD CONTROLLER
50	10953	-	-	-	*	1	糸引きスプリング	SPRING
51	10951	-	-	-	*	1	糸調子棒	TENSION STUD
52	33500	-	-	-	*	1	止めねじ	SET SCREW SM3/32X80 L=12
53	10952	-	-	-	*	1	糸緩め段ピン (長)	PIN (LONG)
54	33160	-	-	-	*	1	第一調子棒 (A)	TENSION STUD
55	37278	-	-	-	*	1	糸緩めピン	TENSION RELEASE PIN
56	10690	-	-	-	*	1	スプリング受け	SPRING STOPPER
57	33134	-	-	-	*	1	止めねじ	SCREW SM9/64X40 L=6
58	10545	-	-	-	*	1	止めねじ	SET SCREW SM11/64X32 L=14

糸調子関係/Tread tension

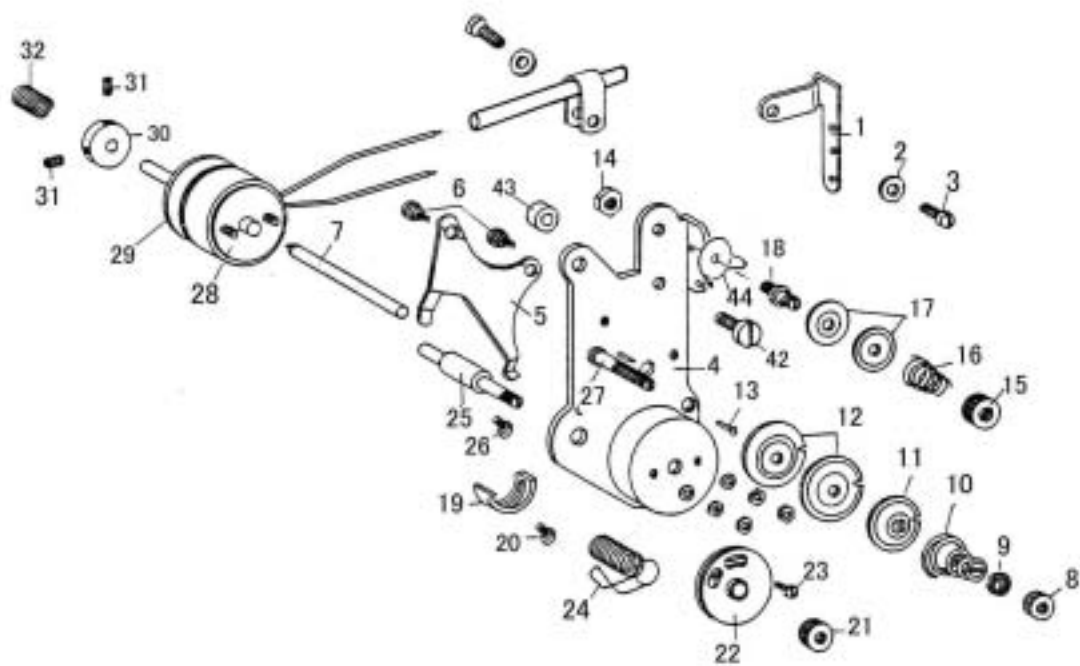

糸調子関係/Thread tension

	部品番号	8GW-1	8CWC-1	8CWC-1-ONU	22GW-1	数量	品名	DESCRIPTION
	PARTS					QTY		
1	35727	-	*	*	-	1	糸調子系掛け	THREAD GUIDE
2	33139	-	*	*	-	1	座金	WASHER
3	15055	-	*	*	-	1	止めねじ	SCREW SM11/64X32 L=9
4	17377C	-	*	*	-	1	調子板(組)	TENSION BRACKET COMPLETE
5	30010	-	*	*	-	1	糸緩め板	TENSION RELEASE PLATE
6	10679	-	*	*	-	2	段ねじ	STUD SCREW 3.4X36
7	37278	-	*	*	-	1	糸緩めピン	TENSION RELEASE PIN
8	37279	-	*	*	-	1	ローレットナット	NUT
9	28206	-	*	*	-	1	ローレットストッパー	STOPPER
10	10693	-	*	*	-	1	糸調子ばね	TENSION SPRING
11	19532	-	*	*	-	1	丸一皿	TENSION DISC WASHER
12	19531	-	*	*	-	2	調子皿	TENSION DISC
13	10793	-	*	*	-	1	糸緩め段ピン	PIN
14	10652	-	*	*	-	1	ナット	NUT
15	20225	-	*	*	-	1	第一調子ローレット	TENSION THUMB NUT
16	20226-01	-	*	*	-	1	第一調子棒スプリング	SPRING
17	20224	-	*	*	-	2	第一調子皿	TENSION DISC
18	20223	-	*	*	-	1	第一調子棒(A)	TENSION STUD
19	10690	-	*	*	-	1	スプリング受け	SPRING STOPPER
20	8100	-	*	*	-	1	止めねじ	SET SCREW 3.4X36 L=6
21	19534	-	*	*	-	1	ローレットナット	NUT
22	10694	-	*	*	-	1	二重皿	THREAD CONTROLLER
23	10695	-	*	*	-	1	止めねじ	SET SCREW SM3/32X80 L=6.5
24	10689	-	*	*	-	1	糸引きスプリング	SPRING
25	19512	-	*	*	-	1	糸調子棒	TENSION STUD
26	10545	-	*	*	-	1	止めねじ	SET SCREW SM11/64X32 L=14
27	19511	-	*	*	-	(1)	糸調子棒	TENSION STUD
28	30006	-	*	*	-	1	プッシュソレノイド(24V)	TENSION SOLENOID (24V)
29	30007	-	*	*	-	1	パッキン	PACKING
30	30008	-	*	*	-	1	糸ゆるめカラー	COLLAR
31	10630	-	*	*	-	2	糸ゆるめカラー止めねじ	SCREW
32	30009	-	*	*	-	1	糸ゆるめカラースプリング	SPRING
42	6604	-	*	*	-	1	調子板止めねじ	SCREW
43	18304	-	*	*	-	1	調子板止め座金	WASHER

糸調子関係/Tread tension

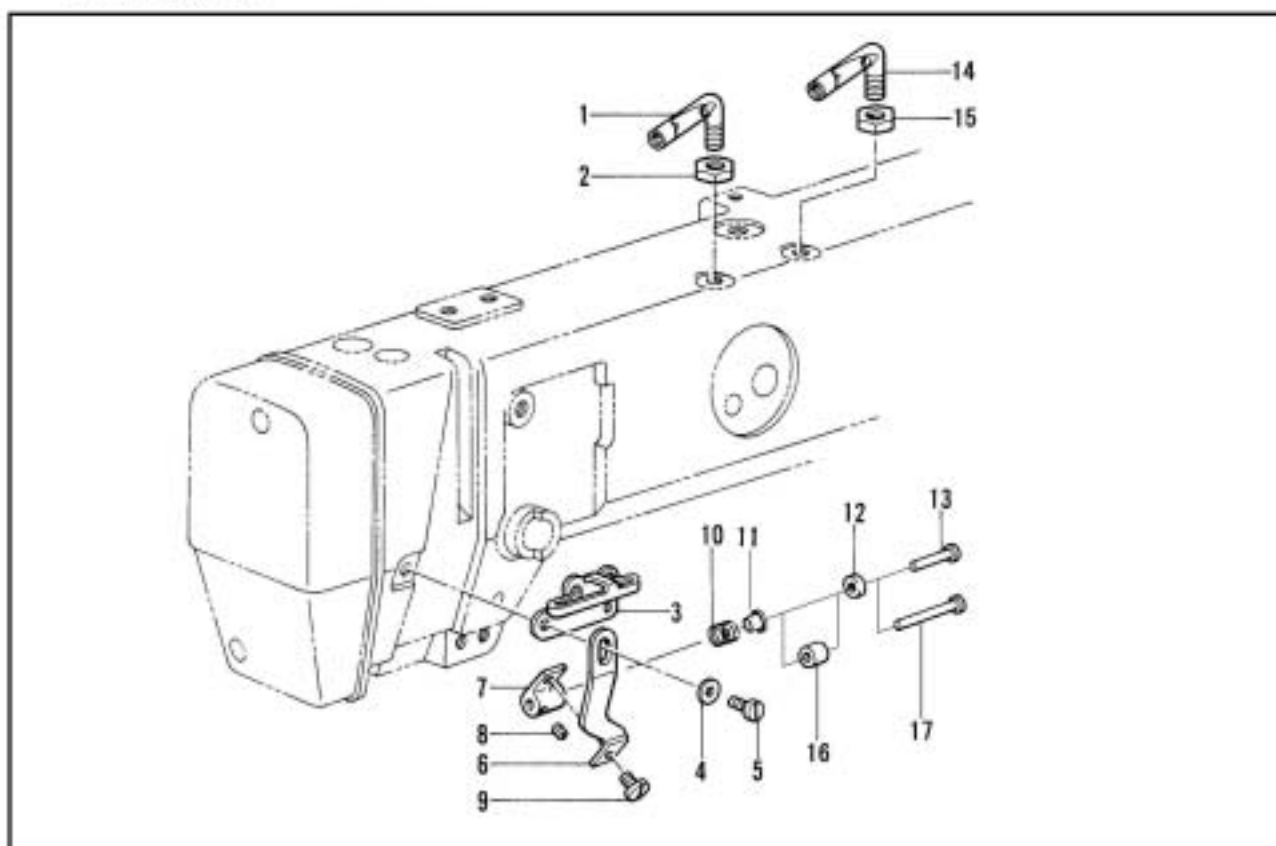

糸巻き関係/Bobbin winder mechanism

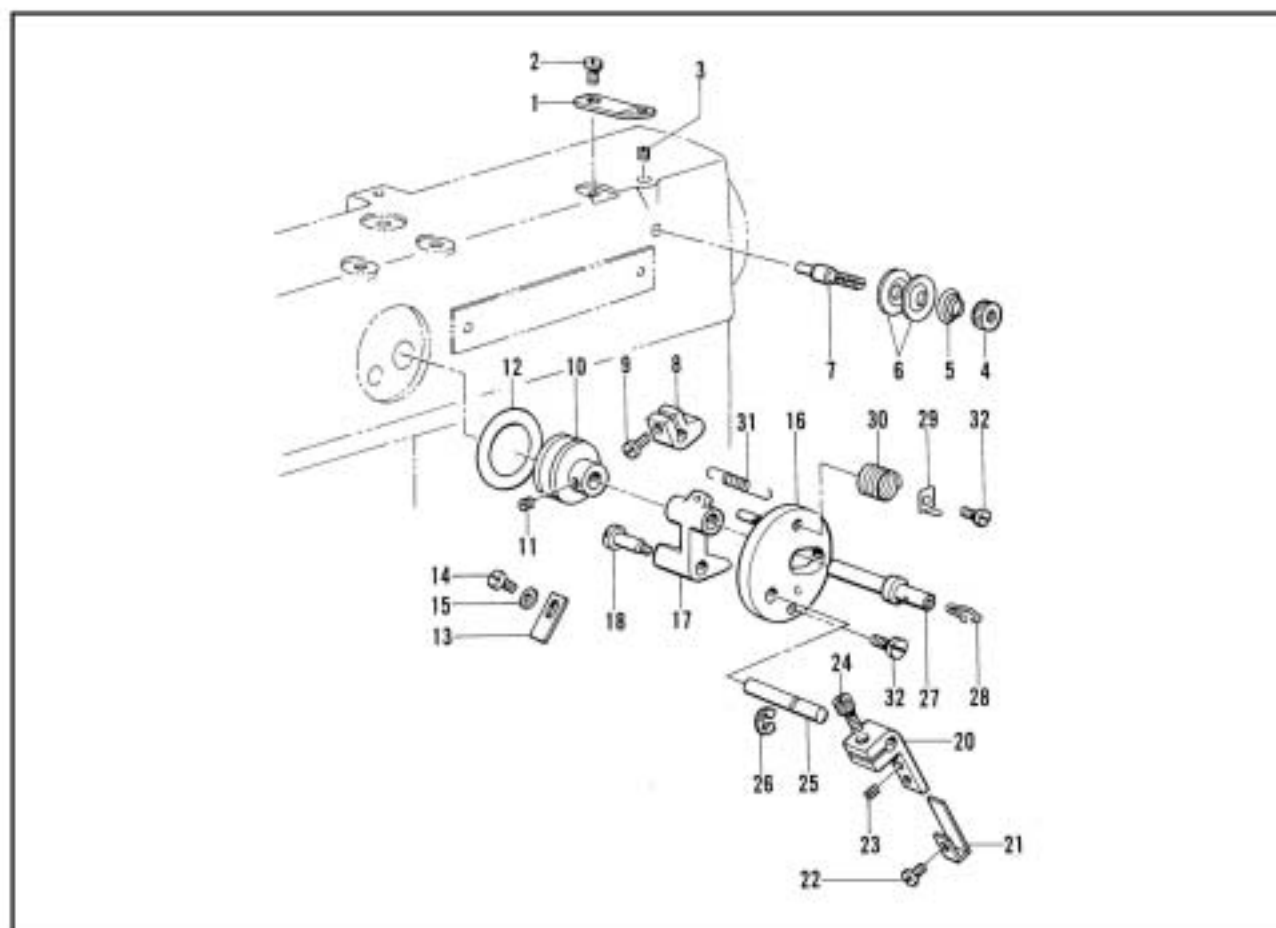

糸調子関係/Thread tension

	部品番号	8GW-1	8GWC-1	8GWC-1-	22GW-1	数量	品名	DESCRIPTION
	PARTS					QTY		
1	11006	*	*	*	*	1	アーム系掛け	THREAD GUIDE
2	13076-02	*	*	*	*	1	ナット	NUT 7/32X40
3	37281	*	*	*	*	1	面系掛け	THREAD GUIDE
4	16287	*	*	*	*	1	座金	WASHER
5	37009	*	*	*	*	1	締めねじ	PINCH SCREW M5X0.8 L=16
6	37289	*	*	*	*	1	糸案内受け金	THREAD GUIDE HOLDER
7	37287	*	*	*	*	1	糸案内ホルダー	THREAD GUIDE HOLDER
8	37283	*	*	*	*	1	止めねじ	SET SCREW M4X0.7 L=3
9	37288	*	*	*	*	1	止めねじ	SET SCREW M4X0.7 L=5
10	37286	*	*	*	*	1	糸案内スプリング	THREAD GUIDE SPRING
11	37284	*	*	*	*	1	糸案内カラー	THREAD GUIDE COLLAR
12	37285	*	*	*	*	1	糸案内リング	THREAD GUIDE RING
13	37282	*	*	*	-	1	糸案内ピン	THREAD GUIDE PIN
14	11006	-	-	-	*	1	アーム系掛け	THREAD GUIDE
15	13076-02	-	-	-	*	1	ナット	NUT SM7/32X40
16	37589	-	-	-	*	1	糸案内カラー	THREAD GUIDE COLLAR
17	33511	-	-	-	*	1	糸案内ピン	THREAD GUIDE PIN

糸巻き関係/Bobbin winder mechanism

	部品番号	8GW-1	8GWC-1	8GWC-1-ONU	22GW-1	数量	品名	DESCRIPTION
	PARTS					QTY		
1	33121	*	*	*	*	1	糸巻き案内板	PIN
2	8040	*	*	*	*	1	止めねじ	SCREW SM9/64X40 L=8
3	33169	*	*	*	*	1	止めねじ	SET SCREW SM3/32X32 L=9
4	8079	*	*	*	*	1	糸巻き調節ローレットナット	NUT
5	33135	*	*	*	*	1	糸巻き調子ばね	BOBBIN WINDER TENSION SPRING
6	33131	*	*	*	*	2	糸巻き調節調子皿	BOBBIN WINDER REGULATING TENSION DISC
7	33201	*	*	*	*	1	糸巻き調節芯棒	BOBBIN WINDER REGULATING STUD
8	28188	*	*	*	*	1	糸巻き板ばね受け	SPRING HOLDER
9	27174	*	*	*	*	1	糸巻き板ばね受け締めねじ	PINCH SCREW M4X0.7 L=10
10	28184	*	*	*	*	1	糸巻きローラー	BOBBIN WINDER WHEEL
11	33122	*	*	*	*	2	糸巻きローラー止めねじ	SET SCREW SM11/64X40 L=6
12	28193	*	*	*	*	1	糸巻きゴム輪	BOBBIN WINDER RIBBER RING
13	28187	*	*	*	*	1	糸巻き板ばね	BOBBIN WINDER SPRING PLATE
14	33127	*	*	*	*	1	糸巻きスプリング止めねじ	SCREW SM9/64X40 L=6
15	28194	*	*	*	*	1	座金	WASHER
16	33166	*	*	*	*	1	糸巻き取り付け板	BOBBIN WINDER BRACKET
17	35945	*	*	*	*	1	糸巻き軸受	BOBBIN WINDER SHAFT HOLDER
18	28183	*	*	*	*	1	糸巻き断ねじ	STUD SCREW M4X0.7
20	35947	*	*	*	*	1	糸巻きレバー	BOBBIN WINDER LEVER
21	33147	*	*	*	*	1	糸巻き調節板ばね	BOBBIN WINDER REGULATING SPRING PLATE
22	10597	*	*	*	*	1	糸巻き調節板ばね止めねじ	SCREW SM1/8X40 L=5
23	33132	*	*	*	*	1	糸巻き調節ねじ	BOBBIN WINDER REGULATING SCREW SM1/8X40
24	33161	*	*	*	*	1	糸巻きレバー止めねじ	PINCH SCREW M5X0.8 L=10
25	33158	*	*	*	*	1	糸巻きレバー軸	BOBBIN WINDER LEVER SHAFT
26	33126	*	*	*	*	1	糸巻きレバー軸止め輪	STOP RING
27	37291	*	*	*	*	1	糸巻き芯棒	BOBBIN WINDER SHAFT
28	35949	*	*	*	*	1	糸巻きピンフック	BOBBIN HOOK
29	33165	*	*	*	*	1	糸巻き糸切りメス	THREAD TRIMMER KNIFE
30	33164	*	*	*	*	1	糸巻き糸切りスプリング	THREAD TRIMMER SPRING
31	33157	*	*	*	*	1	糸巻き復帰ばね	BOBBIN WINDER RETURN SPRING
32	33128	*	*	*	*	2	糸巻き取り付け板止めねじ	SCREW SM9/64X40 L=11.5