

プーリー、上軸/PULLEY, ARM SHAFT

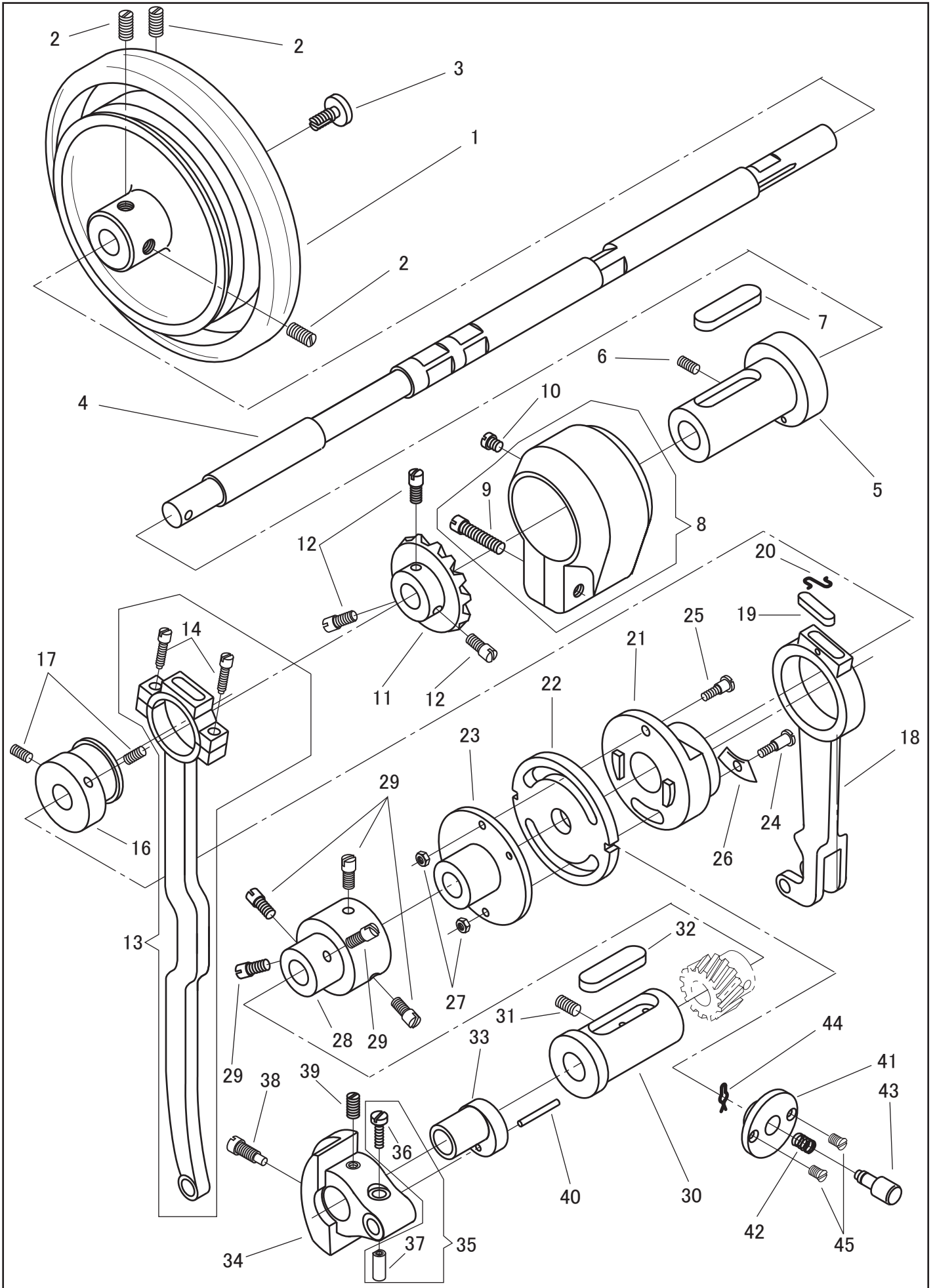

プーリー、上軸/PULLEY, ARM SHAFT

No.	部品番号 PARTS NO.	2B	2B-3	2B-4	個数 QTY	品名	DESCRIPTION
1	1448-A	*	*	*	1	プーリー	PULLEY
2	1327	*	*	*	3	プーリー止めねじ	SCREW 5/16X24 L=13
3	6047	*	*	*	1	プーリー押しねじ	SCREW 5/16X24
4	1229	*	*	*	1	上軸	ARM SHAFT (HORIZONTAL)
5	1810	*	*	*	1	上軸メタル(後)パイプ付	ARM SHAFT (HORIZONTAL) BUSHING WITH PIPE (REAR)
6	6383	*	*	*	1	上軸メタル(後)止めねじ	SCREW 15/64X28 L=10
7	1325	*	*	*	1	上軸メタル(後)フェルト	ARM SHAFT BUSHING FELT
8	1330	*	*	*	1	大ギヤカバーねじ付	ARM SHAFT GEAR COVER WITH SCREW
9	1331	*	*	*	1	大ギヤカバー止めねじ	SCREW 9/32X20 L=24.5
10	1454	*	*	*	1	ギヤカバー油栓	OIL CAP
11	1328	*	*	*	1	大ギヤ	ARM SHAFT GEAR (LARGE)
12	1329	*	*	*	3	大ギヤ止めねじ	SCREW 1/4X40 L=10
13	1775	*	*	*	1	上下送りロッド	FEED LIFTING ROCK SHAFT CONNECTING ROD
14	6029	*	*	*	2	上下送りロッド締めねじ	SCREW 3/16X28
16	1507	*	*	*	1	上下送りカム	FEED LIFTING ECCENTRIC
17	6383	*	*	*	2	上下送りカム止めねじ	SCREW 15/64X28 L=10
18	1727	*	*	*	1	立ロッド(上)	FEED ROCK SHAFT CONNECTING ROD (UPPER)
19	1452	*	*	*	1	立ロッド(上)フェルト	OIL FELT
20	10723	*	*	*	1	立ロッド(上)フェルト押え	OIL FELT STOPPER
21	1726	*	*	*	1	送りカム	FEED ECCENTRIC
22	1725	*	*	*	1	送り調節カム	FEED ECCENTRIC ADJUSTING DISC
23	1353	*	*	*	1	カム土台	FEED ECCENTRIC ADJUSTING FLANGE
24	1354	*	*	*	1	カム段ねじ(A)	SCREW (A) 3/16X32
25	1355	*	*	*	1	カム段ねじ(B)	SCREW (B) 3/16X33
26	1356	*	*	*	1	扇ばね	FEED ECCENTRIC FRICTION SPRING WASHER
27	6360	*	*	*	2	カム段ねじナット	NUT 3/16X32
28	1357	*	*	*	1	カム土台ケース	FEED ECCENTRIC ADJUSTING FLANGE COUPLING
29	1329	*	*	*	5	カム土台ケース止めねじ	SCREW 1/4X40 L=10
30	1322	*	*	*	1	上軸メタル(前)	ARM SHAFT BUSHING (FRONT)
31	1309	*	*	*	1	上軸メタル(前)止めねじ	SCREW 9/32X28 L=11
32	1325	*	*	*	1	上軸メタル(前)フェルト	ARM SHAFT BUSHING FELT
33	1237	*	*	*	1	上送りカム	UPPER FEED ECCENTRIC
34	1808	*	*	*	1	針棒クランク	NEEDLE BAR CRANK
35	6322C	*	*	*	1	九十度パイプ(組)	THREAD TAKE-UP CRANK PIPE COMPLETE
36	6323	*	*	*	1	九十度パイプねじ	SCREW 3/16X32 L=14.5
37	6322	*	*	*	1	九十度パイプ	THREAD TAKE-UP CRANK PIPE
38	8004	*	*	*	1	針棒クランク止めねじ(大)	SCREW 9/32X28
39	1309	*	*	*	1	針棒クランク止めねじ(小)	SCREW 9/32X28 L=11
40	8023-B	*	*	*	1	針棒クランクメタルノックピン	TAPER PIN (3.5 X 40)
41	1848	*	*	*	1	押しボタン台	REGULATING STUD SOCKET
42	20213	*	*	*	1	押しボタンスプリング	FEED REGULATING PUSH BUTTON SPRING
43	20211	*	*	*	1	押しボタン	FEED REGULATING PUSH BUTTON
44	10674	*	*	*	1	押しボタン止割ピン	COTTER PIN
45	17093-02	*	*	*	2	押しボタン台止めねじ	SCREW 9/64X40