

中押え棒、外押え棒/PRESSER BAR, OUTER PRESSER BAR

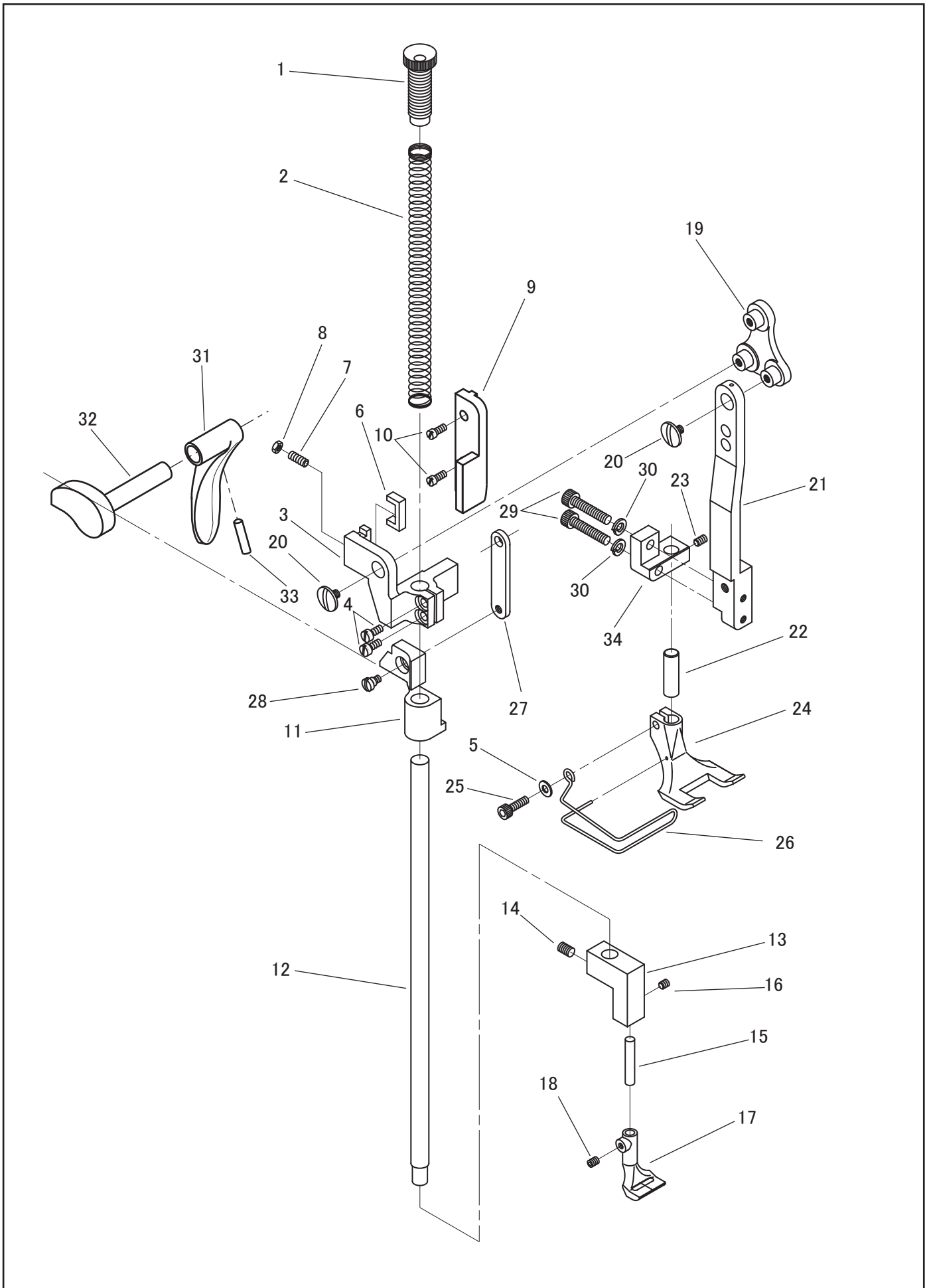

中押え棒、外押え棒/PRESSER BAR, OUTER PRESSER BAR

No.	部品番号 PARTS NO.	2B	2B-3	2B-4	個数 QTY	品名	DESCRIPTION
1	1402	*	*	*	1	筒ねじ	PRESSER BAR THUMB SCREW 5/8X28UN
2	1789	*	*	*	1	中押え棒スプリング	PRESSER BAR SPRING
3	1394	*	*	*	1	中押え棒抱き	PRESSER BAR GUIDE BRACKET
4	50003	*	*	*	2	中押え棒抱き締めねじ	SCREW 3/16X32 L=10.5
5	31207	*	*	*	1	外押え締めねじワッシャー	WASHER
6	1395	*	*	*	1	中押え棒抱きすべり板	PRESSER BAR GUIDE BRACKET GIB
7	8101-10	*	*	*	1	すべり板調節ねじ	SCREW 11/64X40 L=11
8	10652	*	*	*	1	すべり板調節ねじナット	NUT 11/64X40
9	1397	*	*	*	1	中押え棒抱き案内	PRESSER BAR GUIDE BRACKET SUPPORT
10	8060	*	*	*	2	中押え棒抱き案内止めねじ	SCREW 9/64X40 L=8
11	1218	*	*	*	1	中押え棒通り抱き	PRESSER BAR LIFTING AND RELEASING BRACKET
12	1201	*	*	*	1	中押え棒	PRESSER BAR
13	1213	*	*	*	1	中押えホルダー	PRESSER FOOT HOLDER
14	15568	*	*	*	1	中押えホルダー止めねじ	SCREW M6X1 L=8
15	1214	*	*	*	1	中押え連結ピン	PRESSER FOOT CONNECTING PIN
16	38136	*	*	*	1	中押え連結ピン止めねじ	SCREW M4X0.7 L=4
17	1215	*	*	*	1	中押え	PRESSER FOOT
18	37229	*	*	*	1	中押え止めねじ	SCREW M4X0.7 L=5
19	1208	*	*	*	1	三つ孔連結	BELL CRANK
20	1392	*	*	*	2	三つ孔連結止めねじ	SCREW 11/64X40 L=6.5
21	1209	*	*	*	1	外押え棒	OUTER PRESSER BAR
22	1212	*	*	*	1	外押え連結ピン	FEED FOOT CONNECTING PIN
23	37229	*	*	*	1	外押え連結ピン止めねじ	SCREW M4X0.7 L=5
24	1210	*	*	*	1	外押え	FEED FOOT
25	34008	*	*	*	1	外押え締めねじ	SCREW M4X0.7 L=14
26	1211	*	*	*	1	フィンガーガード	FINGER GUARD
27	1399	*	*	*	1	短冊メガネ	LIFTING LEVER LINK
28	1400	*	*	*	1	短冊メガネ止めねじ	SCREW 3/16X32
29	27178	*	*	*	2	外押えホルダー止めねじ	SCREW M5X0.8 L=25
30	90625	*	*	*	2	外押えホルダー止めねじワッシャー	WASHER
31	1911	*	*	*	1	押え上げレバー	PRESSER FOOT LIFTING LEVER (HANDLE)
32	1910	*	*	*	1	押え上げ	PRESSER FOOT LIFTER
33	8020-02	*	*	*	1	ノックピン	PIN
34	1222	*	*	*	1	外押えホルダー	FEED FOOT HOLDER