

弓、押え棒
FOOT LIFTING LEVER, PRESSER BAR

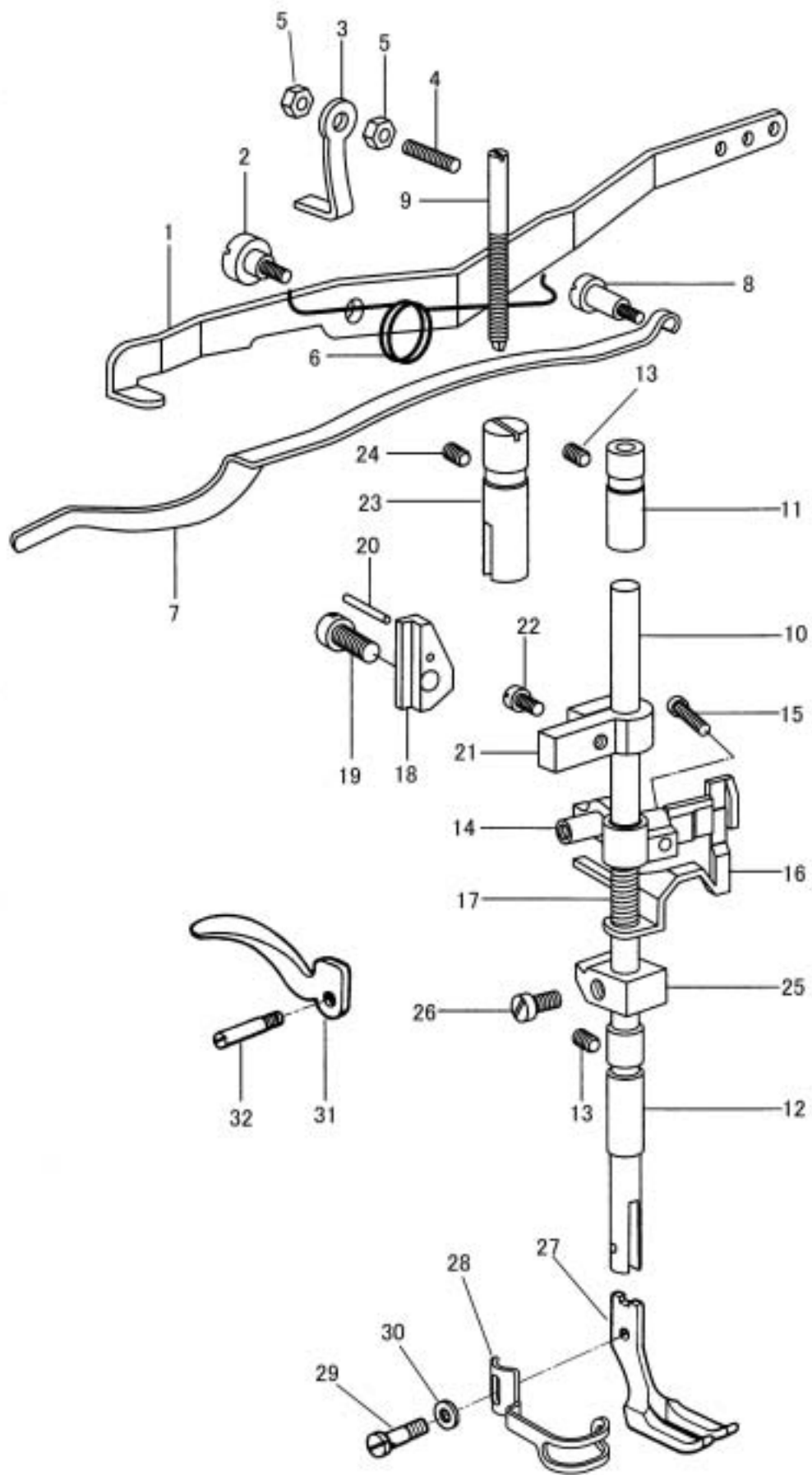

弓、押え棒

FOOT LIFTING LEVER, PRESSER BAR

No.	部品番号 PARTS NO.	-8BL	-8BLV	-8BL-1	-8BLV-1	個数 QTY	品名	DESCRIPTION
1	13056-A	*	*	*	*	1	弓	Foot lifting lever
2	10712	*	*	*	*	1	弓止め	Screw 6.75X24
3	13057	*	*	*	*	1	弓受	Lifting lever stop
4	13058	*	*	*	*	1	ねじ	Screw 6.75X24 L=29
5	13084	*	*	*	*	2	ナット	Nut 6.75X24
6	13059	*	*	*	*	1	弓ばね	Spring
7	10705	*	*	*	*	1	押え棒大板ばね	Presser bar spring (flat)
8	10706	*	*	*	*	1	ねじ	Screw 6.75X24
9	11156	*	*	*	*	1	大板ばね調節ねじ	Screw 1/4X32
10	10540	*	*	*	*	1	押え棒	Presser bar
11	10538	*	*	*	*	1	押え棒上メタル	Presser bar bushing (upper)
12	10539-A	*	*	*	*	1	押え棒下メタル	Presser bar bushing (lower)
13	10761	*	*	*	*	2	ねじ	Screw 6.75X24 L=11
14	18479	*	*	*	*	1	押え棒抱き	Presser bar lifting bracket
15	19518	*	*	*	*	1	ねじ	Screw 11/64X40 L=14
16	10546-A	*	*	*	*	1	押え棒抱き下板	Tension release slide
17	10547	*	*	*	*	1	押え棒抱き下板ばね	Tension release spring
18	10548-A	*	*	*	*	1	押え棒抱き振れ止め台	Lifting bracket guide block
19	10519	*	*	*	*	1	ねじ	Screw 6.75X24 L=17.5
20	15111	*	*	*	*	1	平行ピン	Pin
21	10541	*	*	*	*	1	押え棒案内	Presser bar position guide bracket
22	10662	*	*	*	*	1	ねじ	Screw 5/32X40 L=6.5
23	10543	*	*	*	*	1	案内棒	Presser bar position guide
24	10761	*	*	*	*	1	ねじ	Screw 6.75X24 L=11
25	13360	*	*	*	*	1	押え棒抱きリング	Presser bar spring bracket
26	13365	*	*	*	*	1	ねじ	Screw M4X0.7 L=9
27	10796-S	*	-	*	-	1	外押え	Lifting presser foot
28	19470	*	*	*	*	1	フィンガーガード	Finger guard
29	10749	*	*	*	*	1	ねじ	Screw 3.4X36 L=11
30	10677	*	*	*	*	1	ワッシャー	Washer
31	10659	*	*	*	*	1	押え上げレバー	Presser bar lifter
32	10660	*	*	*	*	1	押え上げレバーピンねじ	Hinge screw 4.5X32 L=7.5