

付屬品(1)  
ACCESSORIES (1)

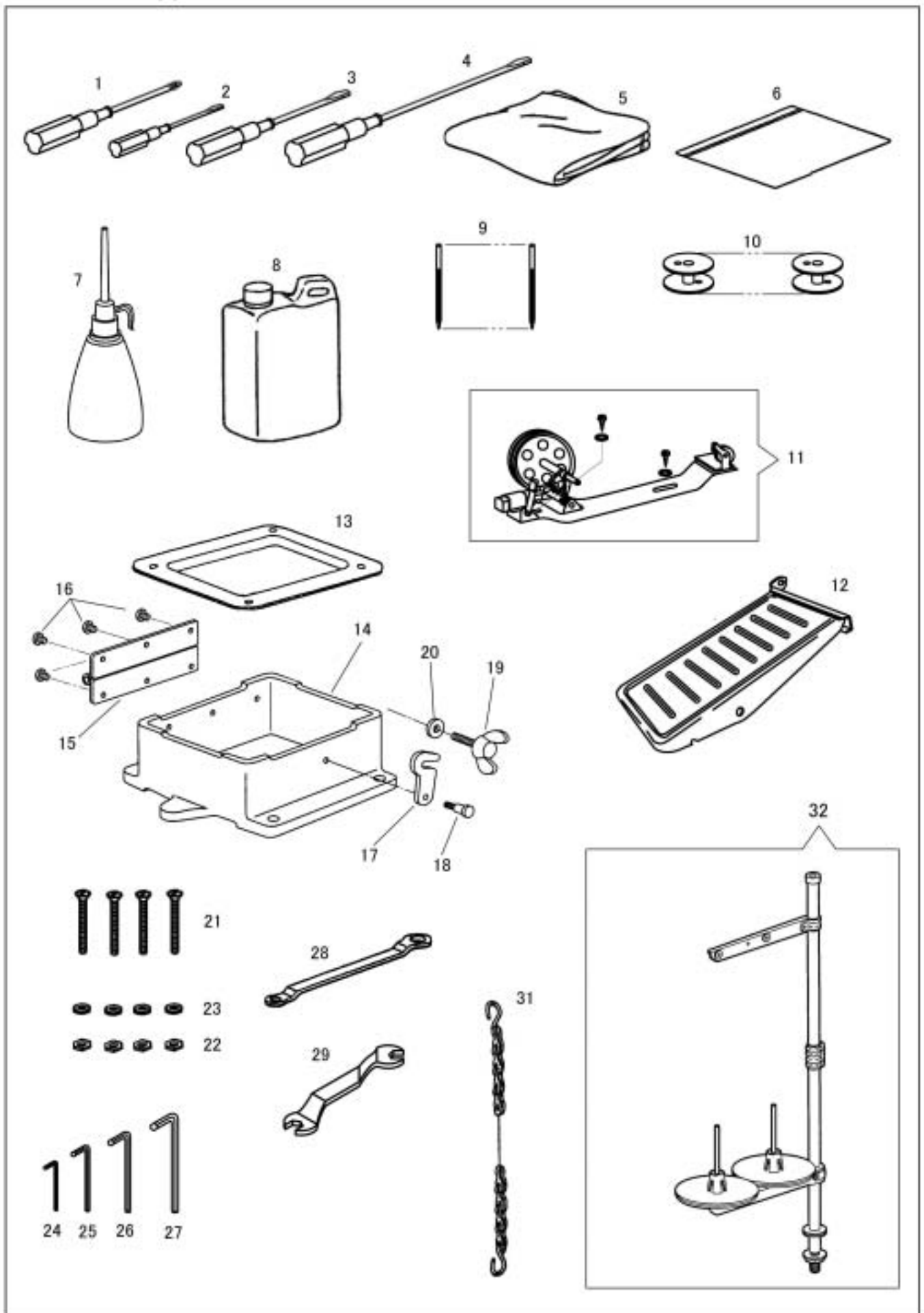

付属品(1)

ACCESSORIES (1)

No.	部品番号 PARTS NO.	-8BL	-8BLV	-8BL-1	-8BLV-1	個数 QTY	品名	DESCRIPTION
1	19473	*	*	*	*	1	十字ドライバー	Screw driver (cross type)
2	8121	*	*	*	*	1	ドライバー(小)	Screw driver (small)
3	8120	*	*	*	*	1	ドライバー(中)	Screw driver (middle)
4	8118	*	*	*	*	1	ドライバー(大)	Screw driver (large)
5	8124	*	*	*	*	1	ビニールカバー(大)	Machine cover (large)
6	8132-A	*	*	*	*	1	部品袋	Accessories pack
7	8125	*	*	*	*	1	油差し	Oiler
8	11193	*	*	*	*	1	油	Oil
9	N0122	*	*	*	*	3	針 DPX17 #22	Needle DPX17 #22
10	15041	*	*	*	*	6	ボビン	Bobbin
11	15101	*	*	*	*	1	糸巻きセット	Bobbin winder complete
12	13098	*	*	*	*	1	ペダルセット	Pedal complete
13	13089	*	*	*	*	1	油受	Oil pan
14	13383	*	*	*	*	1	ベース	Machine base
15	13004	*	*	*	*	1	蝶番	Bed hinge
16	37100	*	*	*	*	6	蝶番止めねじ	Screw M6X1.0 L=10
17	13006	*	*	*	*	1	鍵	Bed clamp
18	19403	*	*	*	*	1	鍵止めねじ	Screw 1/4X28 L=5.4
19	13388-A	*	*	*	*	1	蝶ボルト	Screw M6X1.0 L=20
20	13008	*	*	*	*	1	ワッシャー	Washer
21	13096	*	*	*	*	4	皿小ねじ	Screw 5/16X18 L=75
22	13096-N	*	*	*	*	4	ナット	Nut 5/16X18
23	13096-W	*	*	*	*	4	ワッシャー	Washer
24	10747	*	*	*	*	1	六角レンチ 1/16	Hexagonal wrench 1/16
25	19457	*	*	*	*	1	六角レンチ 2.5mm	Hexagonal wrench 2.5mm
26	19458	*	*	*	*	1	六角レンチ 3mm	Hexagonal wrench 3mm
27	19459	*	*	*	*	1	六角レンチ 4mm	Hexagonal wrench 4mm
28	19462	*	*	*	*	1	メガネレンチ 10X11	Double head wrench 10X11
29	50285	*	*	*	*	1	スパナ 8X8	Spanner 8X8
31	13079	*	*	*	*	1	くさり (1000)	Chain 1000mm
32	35254	*	*	*	*	1	糸立てセット	Thread unwinder complete