

SEIKO

パーツリスト PARTS LIST

TF-6

TF-6B

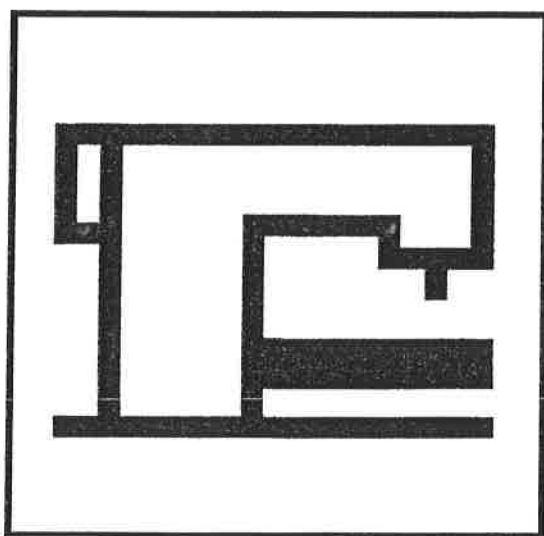

SEIKO SEWING MACHINE CO., LTD.

目次
CONTENTS

	Page
面板、針棒、押え棒 ----- FACE PLATE, NEEDLE BAR, PRESSURE BAR	1, 2
上軸・天秤、送り調節、送り関係 ----- UPPER SHAFT AND TAKE-UP LEVER, FEED REGULATING, FEED MECHANISM	3, 4
カマ土台、下軸、送り竿、関係 ----- SHUTTLE RACE BODY, OSCILLATING SHAFT, FEED ROCK SHAFT, MECHANISM	5, 6
ベルトガード、おぜん ----- BELT GUARD BODY, WORK PLATE BODY	7, 8
付属品関係 ----- ACCESSORIES	9, 10

面板、針棒、押え棒
 FACE PLATE, NEEDLE BAR, PRESSURE BAR

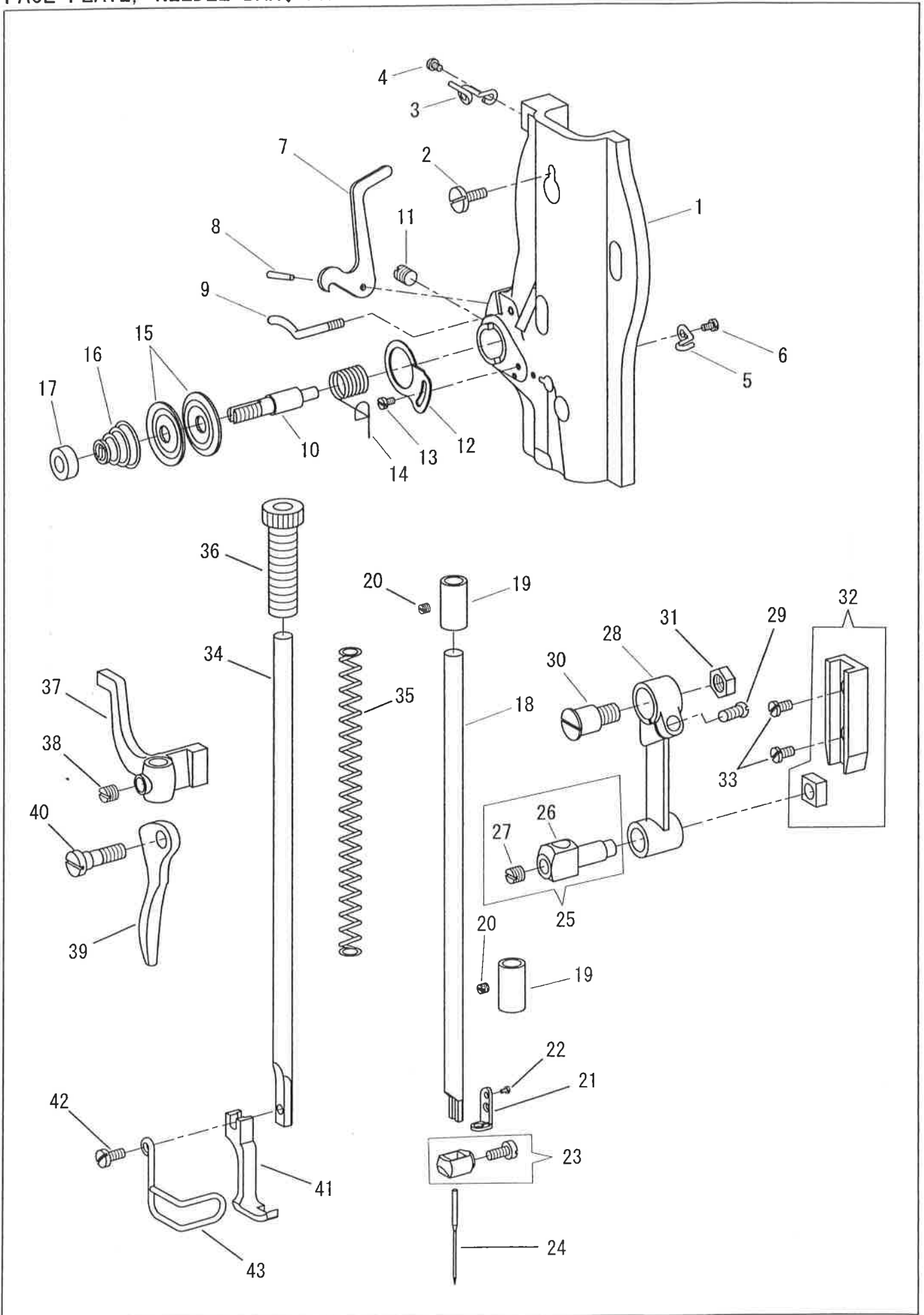

針棒、押え棒、糸調子

NEEDLE BAR, PRESSURE BAR, THREAD CONTROLLER

No.	部品番号 PARTS NO	TF-6	TF-6B	個数 QTY	品名	DESCRIPTION
1	8087	*	*	1	横面	ARM SIDE COVER (FRONT)
2	8089	*	*	1	横面止	SCREW 3/16X32 L=11.0
3	8083	*	*	1	小糸掛	THREAD GUID (SMALL)
4	8103	*	*	1	小糸掛止	SCREW 11/64X40 L=3.5
5	8106	*	*	1	針棒(細針用)	NEEDLE BAR (THIN)
5	8027	*	*	1	針棒(太針用) <オプション>	NEEDLE BAR (THICK) <OPTION>
6	8049	*	*	2	針棒メタル	NEEDLE BAR BUSHING
7	8103	*	*	2	針棒メタル止	SCREW 11/64X40 L=2.3
8	8030	*	*	1	針棒糸掛	N / BAR THREAD GUIDE
9	8031	*	*	1	針棒糸掛止	SCREW 3/32X56 L=4.0
10	8029	*	*	1	針止セット	NEEDLE CLAMP W / SCREW
11	N0411	*	*	1	針 TFX 2 #11	NEEDLE TF X 2 #11
12	8026C	*	*	1	針棒抱き(組)	NEEDLE BAR CONN. STUD COMPLETE
13	8026	*	*	1	針棒抱き	NEEDLE BAR CONN. STUD
14	8097	*	*	1	針棒抱き止	SCREW 15/64X28 L=5.0
15	8025	*	*	1	針棒クランク	NEEDLE BAR CONN. CRANK
16	8104	*	*	1	針棒クランク締めねじ	SCREW FOR 8025
17	8024	*	*	1	針棒クランク段ねじ	SCREW 9/32X28 L=10.0
18	8105	*	*	1	針棒クランク段ねじナット	NUT 9/32X28
19	8116C	*	*	1	針クラ案内箱(組)	N / BAR CONN. CRANK GUIDE COMPLETE
20	8100	*	*	2	案内箱止	SCREW 9/64X40 L=6.5
21	8039	*	*	1	押え棒	PRESSURE BAR
22	8049	*	*	1	押え棒下メタル	PRESSURE BAR BUSHING
23	8103	*	*	1	押え棒下メタル止	SCREW 11/64X40 L=2.3
24	8041	*	*	1	押え棒抱き	PRESSURE BAR BRACKET
25	8042	*	*	2	押え棒抱き止	SCREW 15/64X28 L=5.0
26	8060	*	*	1	押え棒抱き調節ネジ	SCREW 9/64X40 L=8.0
27	8043	*	*	1	ライナー	WEARING PLATE FOR 8041
28	8044	*	*	2	ライナー止	SCREW 1/8X44 L=6.0
29	8075	*	*	1	押え棒抱きすべり板	P/ BAR BRACKET GUIDE
30	8016	*	*	2	押え棒抱きすべり板止	SCREW 9/64X40 L=5.5
31	8036	*	*	1	筒ねじ	PRESSURE BAR THUMB SCREW
32	8037	*	*	1	押え棒スプリング	PRESSURE BAR SPRING
33	8048	*	*	1	糸ゆるめリング	TENSION RELEASE RING
34	8016	*	*	2	糸ゆるめリング止	SCREW 9/64X40 L=5.5
35	8051	*	*	1	糸ゆるめ	TENSION RELEASE LEVER
36	8052	*	*	1	糸ゆるめ段ねじ	HINGE SCREW FOR 8051
37	8050	*	*	1	糸ゆるめ案内ねじ	SCREW FOR 8051
38	8045	*	*	1	押え上げレバー	P / BAR LIFTING LEVER
39	6384	*	*	1	レバー段ねじ	HINGE SCREW FOR 8045
40	8047	*	*	1	押え上げレバー座金	WASHER
41	8101-M	*	*	1	ローラー押え(中)組・φ28	ROLLER PRESSURE FOOT COMP. (φ 28)
42	8040	*	*	1	ローラー押え止	SCREW 9/64X40 L=8.0
43	8190	*	*	1	フィンガーガード	FINGER GUARD
44	8076	*	*	1	糸調子棒	TENSION STUD
45	8060	*	*	1	糸調子棒止	SCREW 9/64X40 L=8.0
46	8077	*	*	2	糸調子皿	TENSION DISC
47	8078	*	*	1	渦巻ばねφ1.4	TENSION SPRING
48	8079	*	*	1	ローレットナット	TENSION THUMB NUT
49	8081	*	*	1	糸引スプリング	THREAD TAKE-UP SPRING
50	8080	*	*	1	糸引スプリング受	T / TAKE-UP SPRING STOP
51	8031	*	*	1	糸引スプリング受止	SCREW 3/32X56 L=4.0
52	8082	*	*	1	大糸掛	THREAD GUID (LARGE)
53	8040	*	*	1	大糸掛止	SCREW 9/64X40 L=8.0

上軸・天秤、送り調節、送り関係
 UPPER SHAFT AND TAKE-UP LEVER, FEED REGULATING, FEED MECHANISM

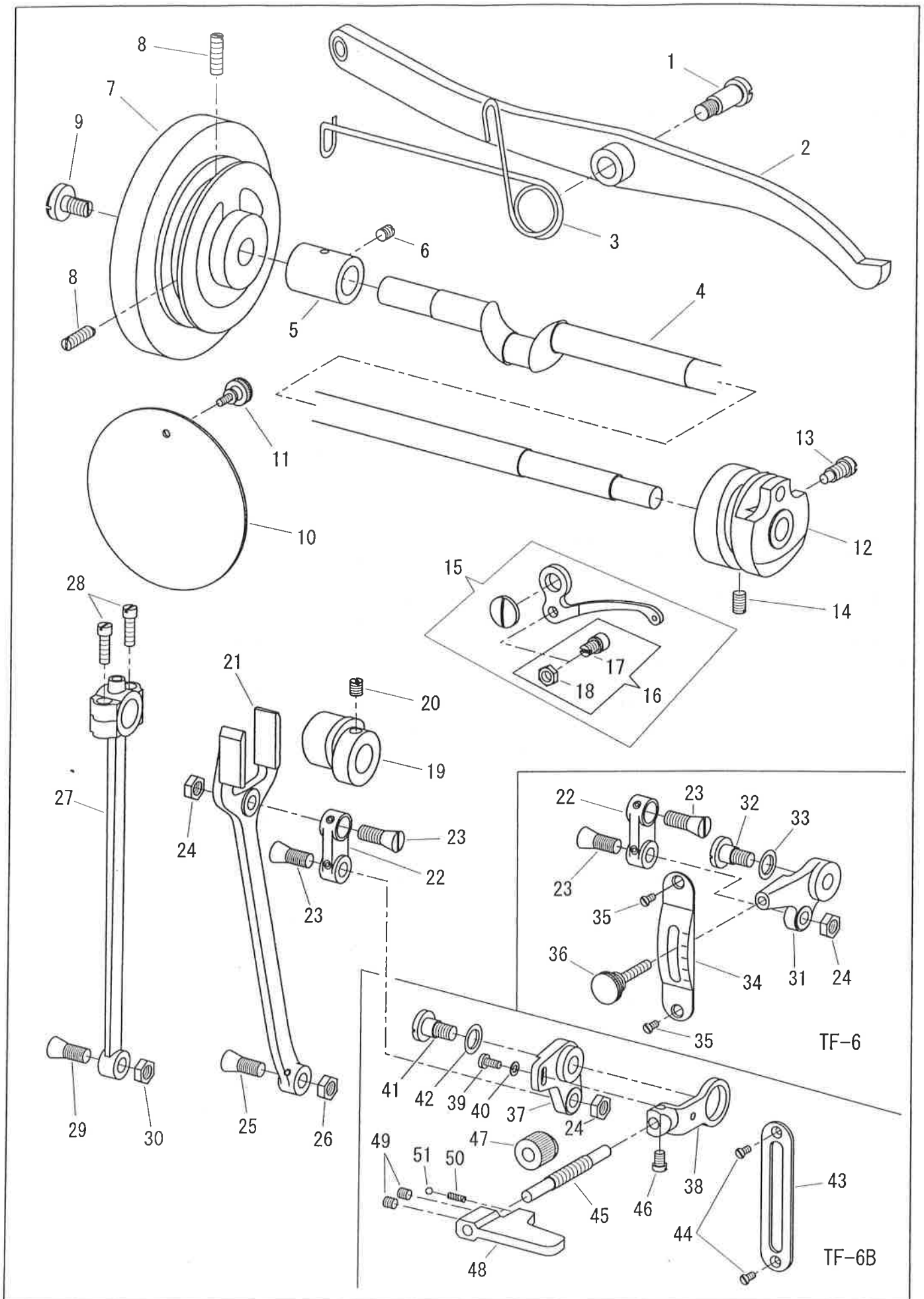

上軸・天秤、送り調節、送り関係

UPPER SHAFT AND TAKE-UP LEVER, FEED REGULATING, FEED MECHANISM

No.	部品番号 PARTS NO	TF-6	TF-6B	個数 QTY	品名	DESCRIPTION
1	8086-01	*	*	1	弓止	HINGE SCREW
2	8084	*	*	1	弓	FOOT LIFTING LEVER
3	8085	*	*	1	弓ばね	F / LIFTING LEVER SPRING
4	8003	*	*	1	上軸	ARM SHAFT
5	8008	*	*	1	後メタル	A / SHAFT BUSHING (REAR)
6	8009	*	*	1	後メタル止	SCREW 15/64X28 L=7.5
7	8195	*	*	1	プーリー	PULLEY
8	6046	*	*	2	プーリー止	SCREW 15/64X28 L=17
9	6047	*	*	1	プーリー押しねじ	ARM SHAFT SCREW 5/16X24 L=10.5
10	8095	*	*	1	丸面(小)	ARM SIDE COVER (SMALL)
11	8093	*	*	1	丸面止	SCREW 9/64X40 L=9.0
12	8005	*	*	1	キャム	THREAD TAKE-UP CAM
13	8004	*	*	1	キャム止(大)	SCREW (LARGE)
14	6383	*	*	1	キャム止	SCREW 15/64X28 L=10.0
15	8034C	*	*	1	天秤(組)	TAKE-UP LEVER COMPLETE
16	8145C	*	*	1	天秤玉、ナット(組)	RULER & STUD COMPLETE
17	8145	*	*	1	天秤玉(7.94)(組)	RULER & STUD (7.94)
18	8146	*	*	1	天秤玉ナット	NUT (SMALL)
19	8006	*	*	1	カム	FEED ECCENTRIC
20	6383	*	*	1	カム止	SCREW 15/64X28 L=10.0
21	8053	*	-	1	二又ロッド	FEED FORKED CONN. ROD
21	8159	-	*	1	二又ロッド	FEED FORKED CONN. ROD
22	8054	*	*	1	メガネ	F / REGULATOR CONN. LINK
23	8014	*	*	2	メガネ皿ねじ	SCREW 9/32X28 L=13.1
24	8105	*	*	2	メガネ皿ねじナット	NUT 9/32X28
25	8014	*	*	1	二又ロッド皿ねじ	SCREW 9/32X28 L=13.1
26	8105	*	*	1	二又ロッド皿ねじナット	NUT 9/32X28
27	8010	*	*	1	立ロッド	FEED CONNECTING ROD
28	8133	*	*	2	立ロッド締ねじ	SCREW FOR 8010
29	8014	*	*	1	立ロッド皿ねじ	SCREW 9/32X28 L=13.1
30	8105	*	*	1	立ロッド皿ねじナット	NUT 9/32X28
31	8001	*	-	1	への字(A)	FEED REGULATOR (A)
32	8056	*	-	1	への字止	SCREW 9/32X28 L=9.4
33	8088	*	-	1	への字ワッシャー	WASHER
34	8002	*	-	1	送り調節目盛板	STITCH LENGTH PLATE
35	7041	*	-	2	送り調節目盛板止	SCREW 1/8X44 L=7.0
36	8057	*	-	1	送り調節ねじ	FEED REGULATOR SCREW 3/16X32 L=27.0
37	8151	-	*	1	への字	FEED REGULATOR
38	8152	-	*	1	への字調節	FEED REGULATOR ADJUST
39	8040	-	*	1	への字調節止	SCREW 9/64X40 L=8.0
40	10677	-	*	1	への字調節止ワッシャー	WASHER
41	8056	-	*	1	への字止	SCREW 9/32X28 L=9.4
42	8088	-	*	1	への字ワッシャー	WASHER
43	8154	-	*	1	レバープレート	STITCH LENGTH PLATE
44	7041	-	*	2	レバープレート止ねじ	SCREW 1/8X44 L=7.0
45	8153	-	*	1	への字ピンねじ	FEED REGULATOR SCREW
46	6341	-	*	1	への字ピンねじ止	SCREW 3/16X32 L=6.5
47	8155	-	*	1	送り調節ローレット	THUMB NUT
48	18027	-	*	1	送り調節レバー	REVERSE FEED LEVER
49	18028	-	*	2	送り調節レバー止ねじ	SET SCREW M5X0.8 L=5.0
50	8157	-	*	1	レバースプリング	FEED REGULATOR SPRING
51	8158	-	*	1	レバーボール(3. 17)	FEED REGULATOR BALL

カマ土台、下軸、送り竿、関係

SHUTTLE RACE BODY, CSCILLATING SHAFT, FEED ROCK SHAFT, MECHANISM

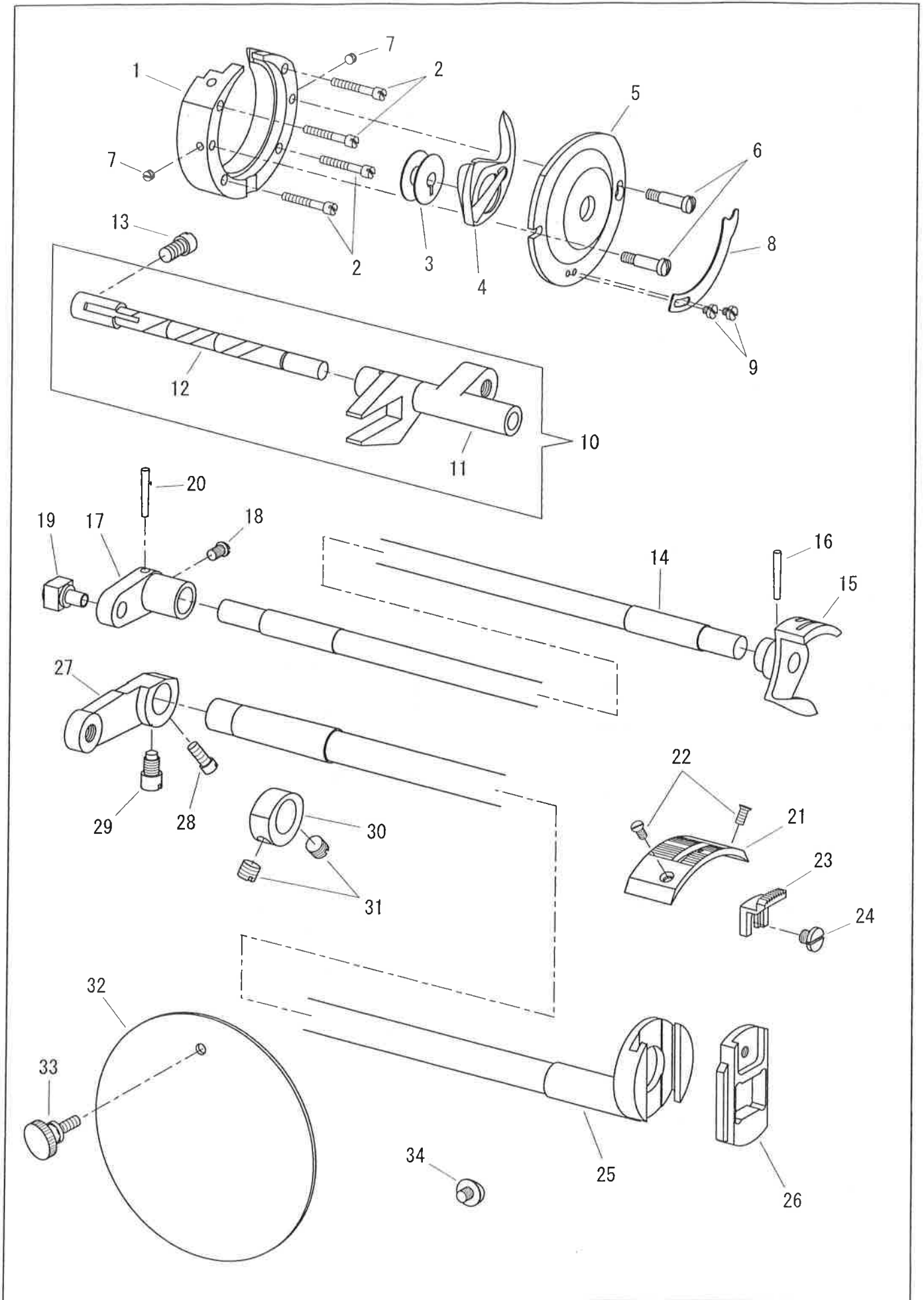

カマ土台、下軸、送り竿、関係

SHUTTLE RACE BODY, CSCILLATING SHAFT, FEED ROCK SHAFT, MECHANISM

No.	部品番号 PARTS NO	TF-6	TF-6B	個数 QTY	品名	DESCRIPTION
1	8021	*	*	1	大ガマ土台	SHUTTLE RACE BODY
2	8022	*	*	4	大ガマ土台止	SCREW 3/32X56 L=17.0
3	8096	*	*	1	ボビン	BOBBIN
4	8028	*	*	1	舟(組)(TF1)	SHUTTLE HOOK COMPLETE
5	8066	*	*	1	カマぶた	SHUTTLE RACE PLATE
6	8067	*	*	2	カマぶた止(大)	SCREW 9/64X40 L=8.0
7	8090	*	*	2	カマぶた止(小)	SCREW 1/8X44 L=2.0
8	8068	*	*	1	カマぶた板ばね	S / RACE COVER SPRING
9	8069	*	*	2	カマぶた板ばね止	SCREW 3/32X56 L=2.2
10	8011C	*	*	1	三又クランク・笛芯(組)	O / ROCK SHAFT CRANK COMPLETE
11	8011	*	*	1	三又クランク	O/ROCK SHAFT CRANK
12	8134	*	*	1	笛芯	SHAFT FOR 8011
13	8013	*	*	1	笛芯止	SCREW FOR 8134 15/64X28 L=6.5
14	8018	*	*	1	下軸	OSCILLATING SHAFT
15	8019	*	*	1	ドライバー	SHUTTLE DRIVER
16	8020-01	*	*	1	テーパピン(3X20L)	TAPER PIN (3 X 20)
17	8015	*	*	1	振り子	O / SHAFT CRANK
18	8016	*	*	1	振り子止	SCREW 9/64X40 L=5.5
19	8017	*	*	1	振り子角玉	SLIDE BLOCK COMPLETE
20	8020-02	*	*	1	テーパピン(3X16L)	TAPER PIN (3 X 16)
21	8065	*	*	1	針板	THROAT PLATE
22	8016	*	*	2	針板止	THROAT PLATE SCREW 1/8X44 L=7.0
23	8063	*	*	1	送り歯	FEED DOG
24	8064	*	*	1	送り歯止	FEED DOG SCREW 11/64X40 L=4.0
25	8061	*	*	1	送り竿	FEED ROCK SHAFT
26	8062	*	*	1	送り土台	FEED BASE
27	8058	*	*	1	連結	FEED ROCK SHAFT CRANK
28	8060	*	*	1	連結止(小)	SCREW (SMALL) 9/64X40 L=8.0
29	8059	*	*	1	連結止(大)	SCREW (LARGE) 15/64X28 L=10.0
30	8091	*	*	1	送り竿カラー	FEED ROCK SHAFT COLLAR
31	8097	*	*	2	送り竿カラー止	SCREW 15/64X28 L=5.0
32	8094	*	*	1	丸面(大)	ARM SIDE COVER (LARGE)
33	8093	*	*	1	丸面止	SCREW 9/64X40 L=9.0
34	30046	*	*	1	アース線止	SCREW ,TRUSS M4X0.7 L=4.0

ベルトガード、おぜん
BELT GUARD BODY, WORK PLATE BODY

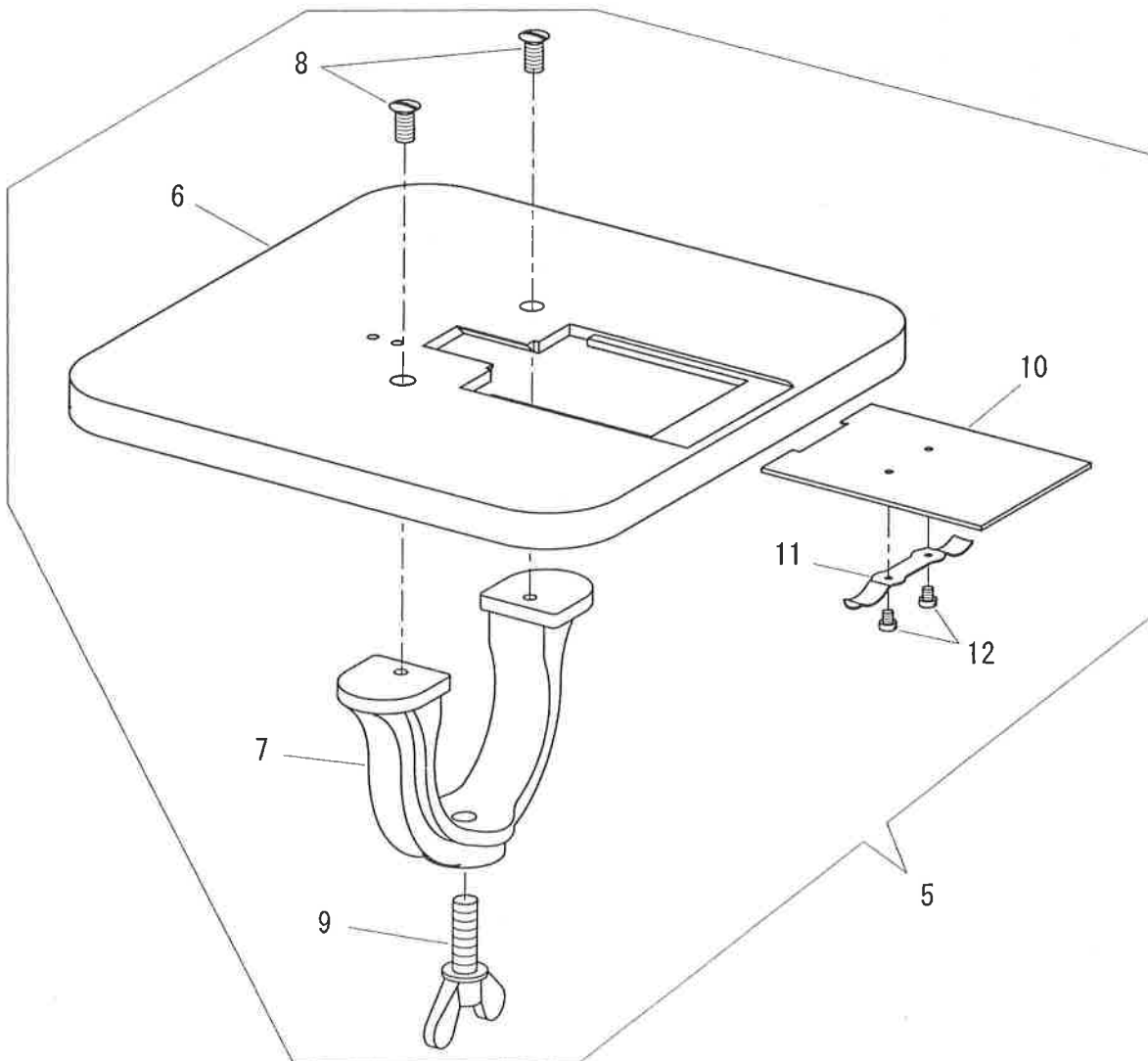
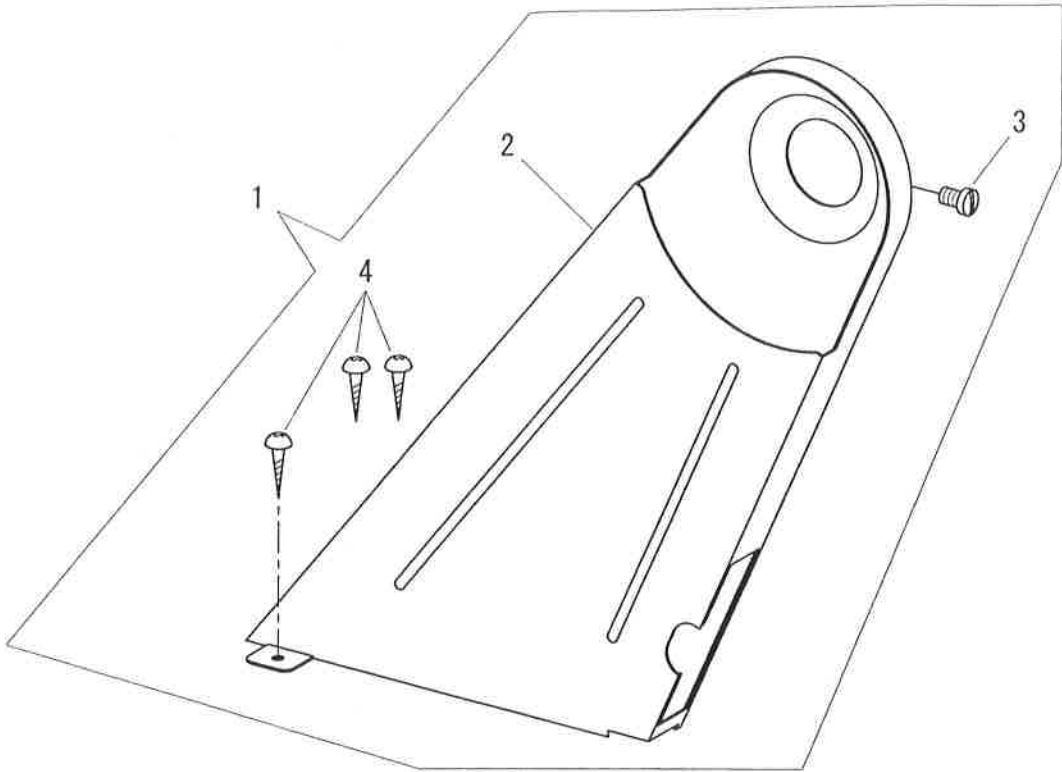

ベルトガード、おぜん

BELT GUARD BODY, WORK PLATE BODY

No.	部品番号 PARTS NO	TF-6	TF-6B	個数 QTY	品名	DESCRIPTION
1	8147C	*	*	1	ベルトガード(組)	BELT GUARD BODY COMPLETE
2	8147	*	*	1	ベルトガード	BELT GUARD BODY
3	10561	*	*	1	ベルトガード止ねじ	SCREW 11/64X32 L=6.5
4	15081	*	*	3	ベルトガード止木ねじ	BELT GUARD WOOD SCREW

おぜん < オプションパーツ >

WORK PLATE BODY < Optional Equipment >

5	8136C	*	*	1	おぜん(組)	WORK PLATE BODY COMPLETE
6	8136	*	*	1	おぜん	WORK PLATE BODY
7	8138	*	*	1	おぜん土台	WORK PLATE BASE
8	6031-02	*	*	2	おぜん止	N / PLATE SCREW 11/64X40 L=8.3
9	8139	*	*	1	おぜん土台止	WORK PLATE WING SCREW 5/16X18UNC L=38
10	8137	*	*	1	おぜん角板	WORK PLATE SLIDE PLATE
11	6034	*	*	1	角板裏ばね	SLIDE PLATE SPRING
12	6035	*	*	2	角板裏ばね止	SCREW 3/32X56 L=2

付属品関係
ACCESSORIES

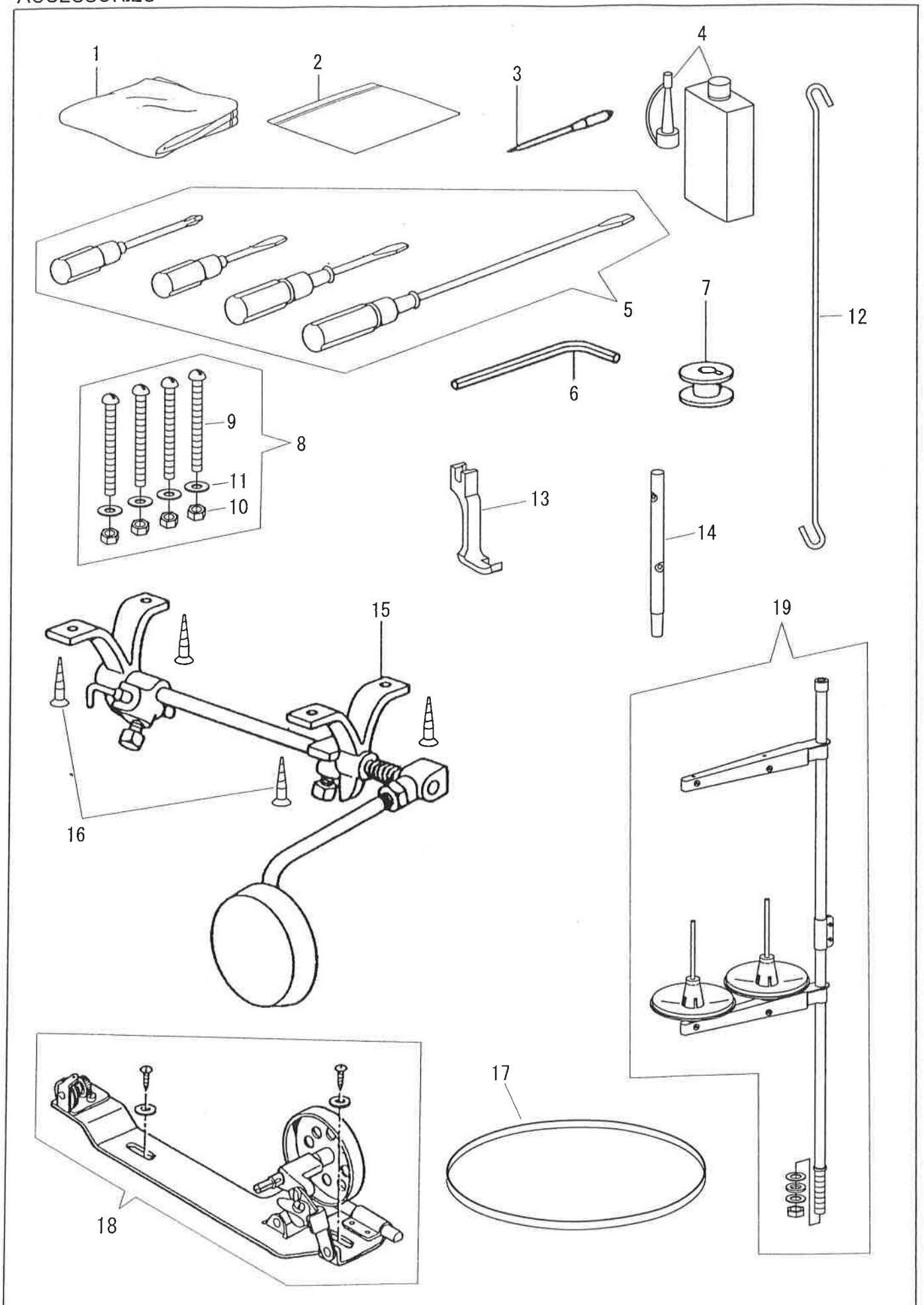

付属品関係
ACCESSORIES

No.	部品番号 PARTS NO	TE-6	TE-6B	個数 QTY	品名	DESCRIPTION
1	8124	*	*	1	ビニールカバー(大)	VINYL COVER (LARGE)
2	8132-A	*	*	1	部品袋チャック付	ACCESSORYS PACK
3	N0319	*	*	3	針 DB X 1 #19	NEEDLE DB X 1 #19
4	8123	*	*	1	油(差口付き)	OIL WITH OILER (SMALL)
5	25649C	*	*	1	ドライバー4点組	SCREW DRIVER COMPLETE
6	19457	-	*	1	六角レンチ (2.5mm)	WRENCH (2.5mm)
7	8096	*	*	6	ボビン	BOBBIN
8	8126	*	*	4	本体止(組)	SCREW W / NUT & WASHER
9	8126-01	*	*	4	本体止ボルト	SCREW 1/4 L=65
10	8126-02	*	*	4	本体止ナット	NUT 1/4
11	8126-03	*	*	4	本体止ワッシャー	WASHER
12	8119	*	*	1	吊り棒	LIFTING LEVER CONN. ROD
13	8101-M	*	*	1	ローラー押え(中)組・φ28	ROLLER PRESSURE FOOT COMP. (φ28)
14	8102	*	*	1	糸立棒	ARM SPOOL PIN
15	8129	*	*	1	膝上げセット	KNEE LIFTER COMPLETE
16	8130	*	*	4	膝上げセット止木ねじ	WOOD SCREW (4.5 X 2.5)
17	7046	*	*	1	定規	CLOTH EDGE GUIDE
18	7047	*	*	1	定規止	SCREW FOR 7046
19	8128	*	*	1	油受	OIL PAN
20	7048	*	*	1	糸巻きセット	BOBBIN WINDER
21	35254	*	*	1	糸立セット	THREAD UNWINDER COMP.

SEIKO SEWING MACHINE CO., LTD.

2-13-6 Sakaecho, Funabashi-shi Chiba Prefecture,
273-0018, Japan

TEL: 81-47-420-3561 (Overseas dept.)

FAX: 81-47-420-3560

E-mail: export@seiko-sewing.co.jp

<http://www.seiko-sewing.co.jp/>

セイコーミシン株式会社

〒273-0018 千葉県船橋市栄町2-13-6

TEL: 047-420-3561, IP電話: 050-3535-3491

FAX: 047-420-3560

E-mail: eigyo@seiko-sewing.co.jp

(国内営業)

Parts No. PB66100 (0418)