

SEIKO

パーツリスト PARTS LIST

SKZ-6B

SKZ-6B-3

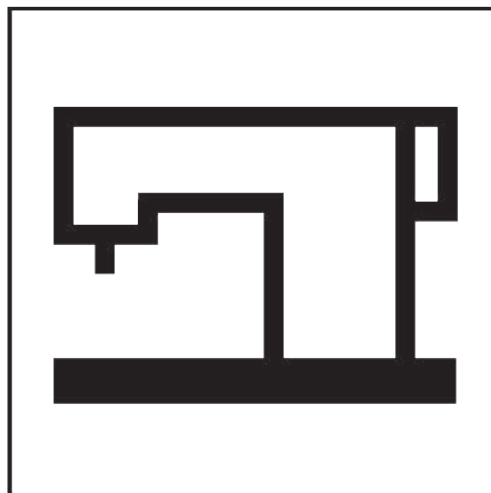

SEIKO SEWING MACHINE CO., LTD.

目次
CONTENTS

	Page
面板、天秤カバー FACE PLATE, THREAD TAKE-UP LEVER COVER	1, 2
プーリー、上軸 PULLEY, ARM SHAFT	3, 4
立軸、かま ARM SHAFT (UPRIGHT), ROTATING HOOK	5, 6
押え棒、針棒、天秤 PRESSER BAR, NEEDLE BAR, THREAD TAKE-UP LEVER	7, 8
針板、送り機構 THROAT PLATE, FEED MECHANISM	9, 10
糸調子、弓 THREAD TENSION, FOOT LIFTING LEVER	11, 12
返し機構 FEED REVERSING MECHANISM	13, 14
ベルトガード BELT GUARD	15, 16
針振りギヤー、上板 ZIGZAG GEAR, ARM TOP COVER SKZ-6B	17, 18
針振りギヤー、上板 ZIGZAG GEAR, ARM TOP COVER SKZ-6B-3	19, 20
付属品1 ACCESSORIES 1	21, 22
付属品2 ACCESSORIES 2	23, 24
別売品 OPTION	25, 26
ゲージ表 TABLE OF GAUGE PARTS	27

面板、天秤カバー / FACE PLATE, THREAD TAKE-UP LEVER COVER

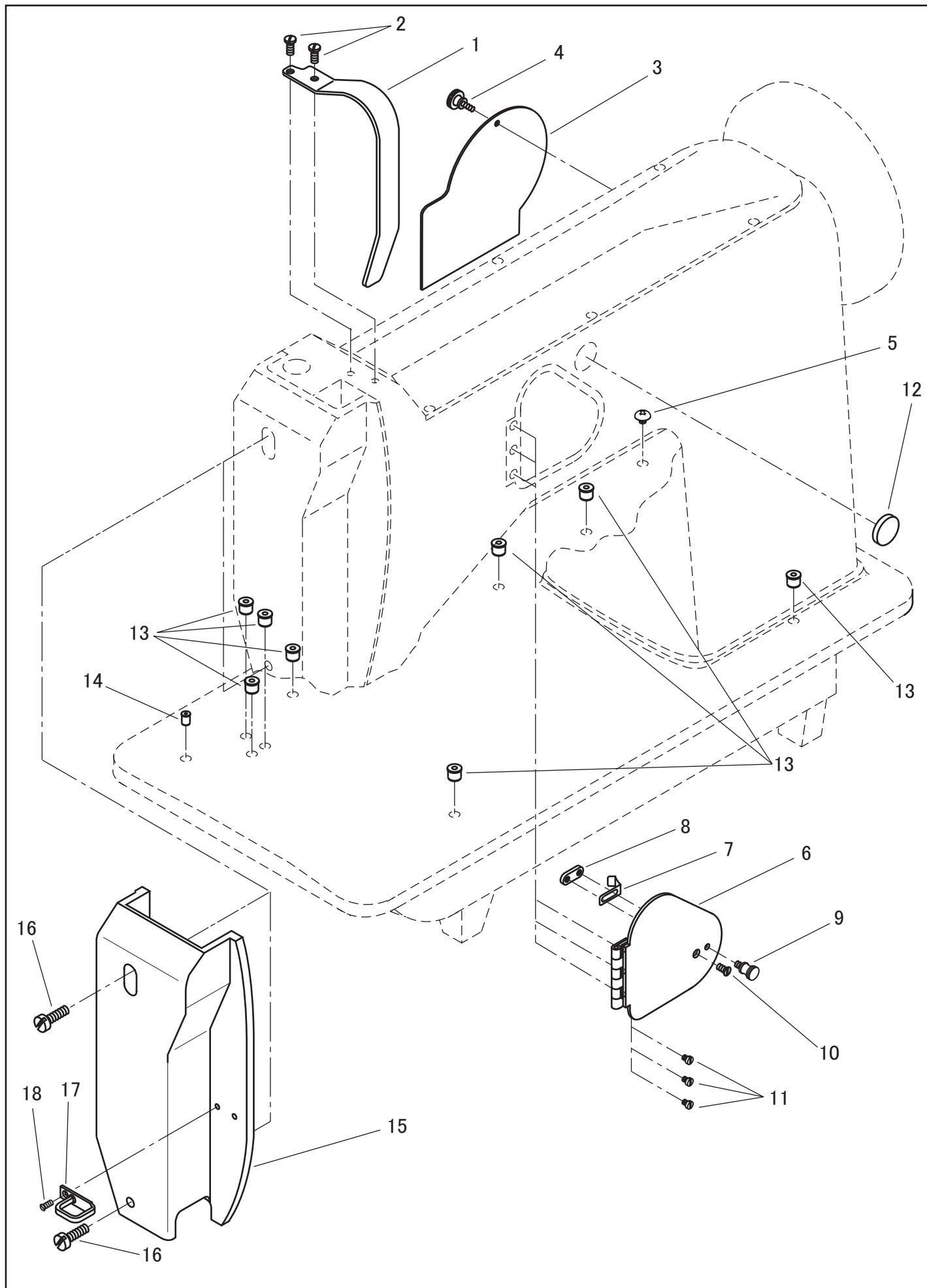

面板、天秤カバー/FACE PLATE, THREAD TAKE-UP LEVER COVER

No.	部品番号 PARTS NO.	6B	6B-3	個数 QTY	品名	DESCRIPTION
1	1997	*	*	1	天秤カバー	THREAD TAKE-UP LEVER COVER
2	15007	*	*	2	天秤カバー止めねじ	SCREW SM9/64X40
3	1983	*	*	1	アーム側面カバー	ARM SIDE COVER
4	8093	*	*	1	アーム側面カバー止めねじ	SCREW SM9/64X40
5	30046	*	*	1	アース線止めねじ	SCREW M4X0.7
6	1849	*	*	1	針振り調節開閉板(組)	ZIGZAG ADJUSTER COVER COMPLETE
7	1850	*	*	1	針振り調節開閉板ばね	ZIGZAG ADJUSTER COVER SPRING
8	1851	*	*	1	針振り調節開閉板ばね受	SPRING STOP
9	10699	*	*	1	針振り開閉板つまみ	THUMB SCREW 3.4X36
10	13023	*	*	1	針振り調節開閉板ばね止めねじ	SCREW 3.4X36
11	15039	*	*	3	針振り調節開閉板止めねじ	SCREW FOR 15036
12	1803	*	*	1	アームゴム栓	ARM RUBBER PLUG
13	10794	*	*	8	玉入カップ(3/8)	BALL TYPE OIL CUP (3/8)
14	10721	*	*	1	玉入カップ(1/4)	BALL TYPE OIL CUP (1/4)
15	1806	*	*	1	面板	FACE PLATE
16	1427	*	*	2	面板止めねじ	SCREW SM15/64X28 L=19.5
17	10682	*	*	1	面板糸掛	FACE PLATE THREAD GUIDE
18	10685	*	*	1	面板糸掛止めねじ	SCREW 3.4X36

プーリー、上軸/PULLEY, ARM SHAFT

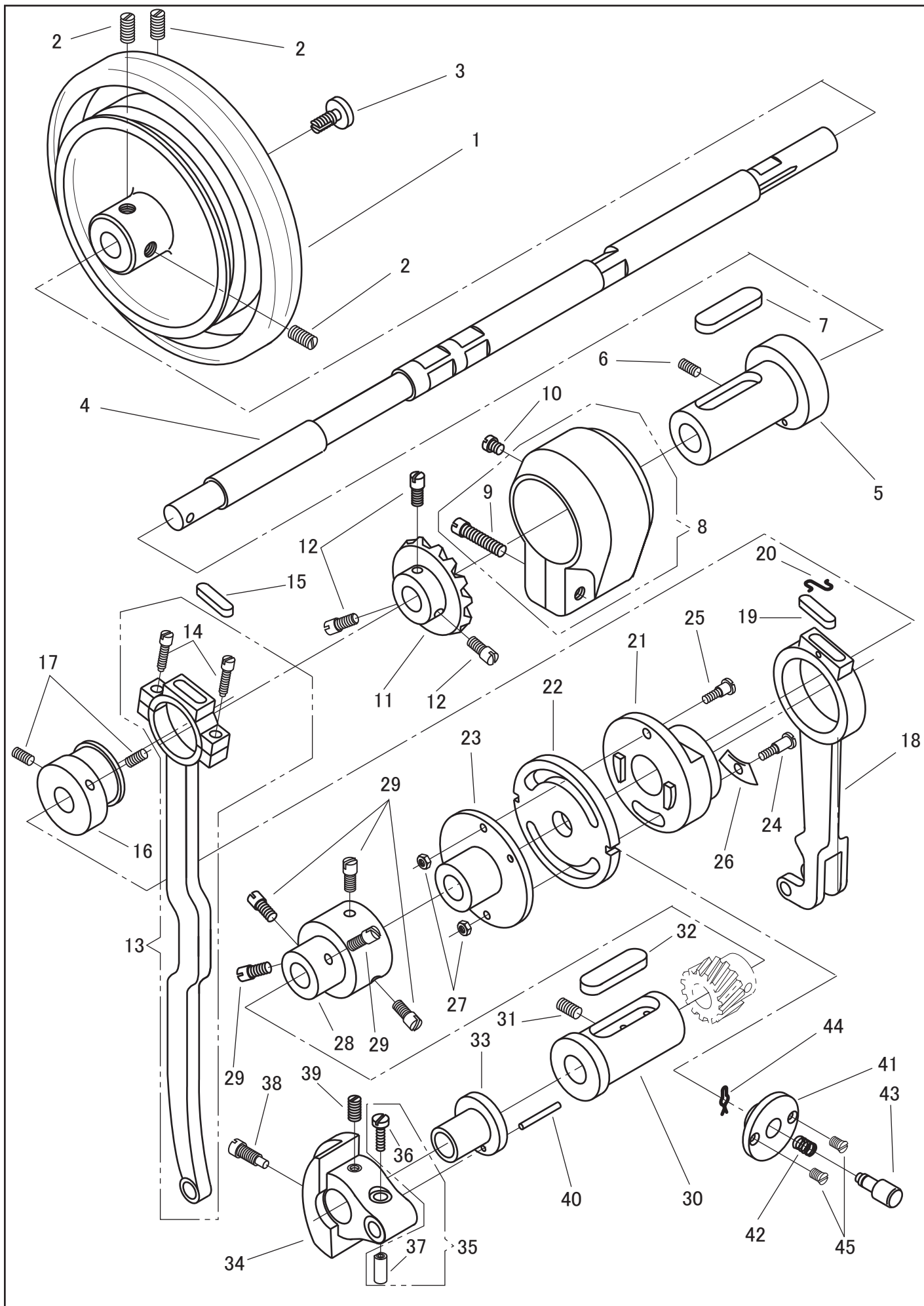

プーリー、上軸/PULLEY, ARM SHAFT

No.	部品番号 PARTS NO.	品	個数 QTY	品名	DESCRIPTION
1	1448-A	*	1	プーリー	PULLEY
2	1327	*	3	プーリー止めねじ	SCREW SM5/16X24 L=13
3	6047	*	1	プーリー押しねじ	SCREW SM5/16X24
4	1807	*	1	上軸	ARM SHAFT (HORIZONTAL)
5	1810	*	1	上軸メタル(後)パイプ付	ARM SHAFT (HORIZONTAL) BUSHING WITH PIPE (BACK)
6	6383	*	1	上軸メタル(後)止めねじ	SCREW SM15/64X28 L=10
7	1325	*	1	上軸メタル(後)フェルト	ARM SHAFT BUSHING FELT
8	1330	*	1	大ギヤカバーねじ付	ARM SHAFT GEAR COVER WITH SCREW
9	1331	*	1	大ギヤカバー止めねじ	SCREW SM9/32X20 L=24.5
10	1454	*	1	ギヤカバー油栓	OIL CAP
11	1328	*	1	大ギヤ	ARM SHAFT GEAR (LARGE)
12	1329	*	3	大ギヤ止めねじ	SCREW SM1/4X40 L=10
13	1775	*	1	上下送りロッド	FEED LIFTING ROCK SHAFT CONNECTING ROD
14	6029	*	2	上下送りロッド締めねじ	SCREW SM3/16X28
15	1452	*	1	上下送りロッドフェルト	OIL FELT
16	1507	*	1	上下送リカム	FEED LIFTING ECCENTRIC
17	6383	*	2	上下送リカム止めねじ	SCREW SM15/64X28 L=10
18	1727	*	1	立ロッド(上)	FEED ROCK SHAFT CONNECTING ROD (UPPER)
19	1452	*	1	立ロッド(上)フェルト	OIL FELT
20	10723	*	1	立ロッド(上)フェルト押え	OIL FELT STOPPER
21	1726	*	1	送リカム	FEED ECCENTRIC
22	1725	*	1	送リ調節カム	FEED ECCENTRIC ADJUSTING DISC
23	1353	*	1	カム土台	FEED ECCENTRIC ADJUSTING FLANGE
24	1354	*	1	カム段ねじ(A)	SCREW (A) SM3/16X32
25	1355	*	1	カム段ねじ(B)	SCREW (B) SM3/16X33
26	1356	*	1	扇ばね	FEED ECCENTRIC FRICTION SPRING WASHER
27	6360	*	2	カム段ねじナット	NUT SM3/16X32
28	1357	*	1	カム土台ケース	FEED ECCENTRIC ADJUSTING FLANGE COUPLING
29	1329	*	5	カム土台ケース止めねじ	SCREW SM1/4X40 L=10
30	1322	*	1	上軸メタル(前)	ARM SHAFT BUSHING (FRONT)
31	1309	*	1	上軸メタル(前)止めねじ	SCREW SM9/32X28 L=11
32	1325	*	1	上軸メタル(前)フェルト	ARM SHAFT BUSHING FELT
33	1809	*	1	針棒クランクメタル	NEEDLE BAR CRANK BUSHING
34	1808	*	1	針棒クランク	NEEDLE BAR CRANK
35	6322C	*	1	九十度パイプ(組)	THREAD TAKE-UP CRANK PIPE COMPLETE
36	6323	*	1	九十度パイプねじ	SCREW SM3/16X32 L=14.5
37	6322	*	1	九十度パイプ	THREAD TAKE-UP CRANK PIPE
38	8004	*	1	針棒クランク止めねじ(大)	SCREW SM9/32X28
39	1309	*	1	針棒クランク止めねじ(小)	SCREW SM9/32X28 L=11
40	8023-A	*	1	針棒クランクメタルノックピン	TAPER PIN (3.5 X 25)
41	1848	*	1	押しボタン台	REGULATING STUD SOCKET
42	20213	*	1	押しボタンスプリング	FEED REGULATING PUSH BUTTON SPRING
43	20211	*	1	押しボタン	FEED REGULATING PUSH BUTTON
44	10674	*	1	押しボタン止割ピン	COTTER PIN
45	17093-02	*	2	押しボタン台止めねじ	SCREW SM9/64X40

立軸、かま/ ARM SHAFT (UPRIGHT), ROTATING HOOK

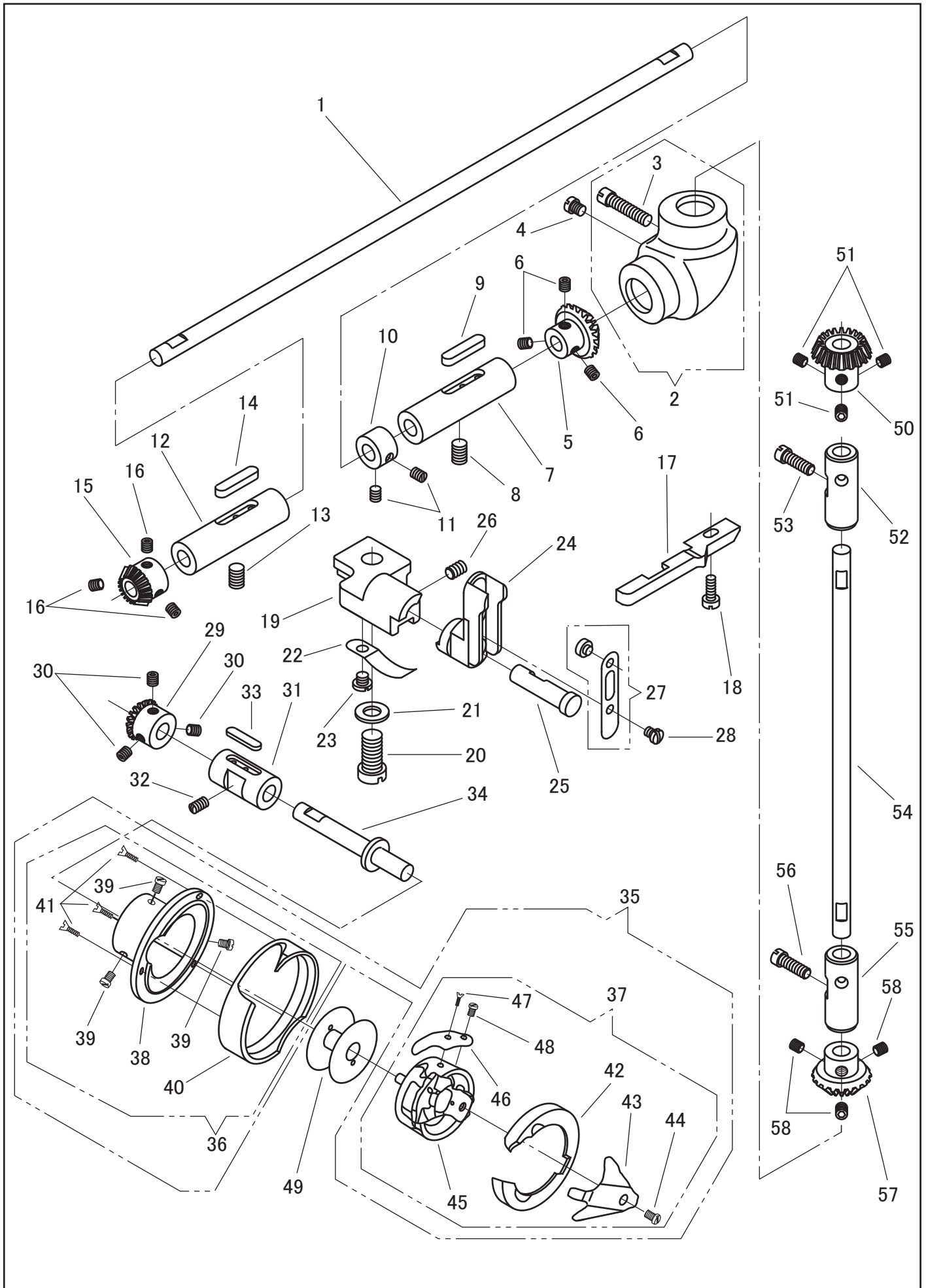

立軸、かま/ARM SHAFT (UPRIGHT), ROTATING HOOK

No.	部品番号 PARTS NO.	6B	6B-3	個数 QTY	品名	DESCRIPTION
1	1532	*	*	1	下軸	LOWER SHAFT
2	1337	*	*	1	下軸ギヤーカバーねじ付	LOWER SHAFT GEAR COVER WITH SCREW
3	1331	*	*	1	下軸ギヤーカバー止めねじ	SCREW SM9/32X20 L=24.5
4	1454	*	*	1	ギヤーカバー油栓	OIL CAP
5	1336	*	*	1	下軸ギヤー(後)	LOWER SHAFT GEAR (BACK)
6	10828-A	*	*	3	下軸ギヤー(後)止めねじ	SCREW SM1/4X40 L=5
7	1340	*	*	1	下軸メタル(後)	H/SHAFT BUSHING (REAR)
8	6042	*	*	1	下軸メタル(後)止めねじ	SCREW SM5/16X24 L=9
9	17026	*	*	1	下軸メタル(後)フェルト	OIL FELT
10	1342	*	*	1	下軸カラー	LOWER SHAFT COLLAR
11	8097	*	*	2	下軸カラー止めねじ	SCREW SM15/64X28 L=5
12	1548	*	*	1	下軸メタル(前)	LOWER SHAFT BUSHING (FRONT)
13	1327	*	*	1	下軸メタル(前)止めねじ	SCREW SM5/16X24 L=13
14	17026	*	*	1	下軸メタル(前)フェルト	OIL FELT
15	1531	*	*	1	下軸ギヤー(前)	LOWER SHAFT GEAR (FRONT)
16	10828-A	*	*	3	下軸ギヤー(前)止めねじ	SCREW SM1/4X40 L=5
17	1856	*	*	1	かま受	HOOK RETAINER
18	6025	*	*	1	かま受止めねじ	SCREW SM11/64X40 L=12
19	1528	*	*	1	かま押え土台	HOOK RETAINER BRACKET
20	1346	*	*	1	かま押え土台止めねじ	SCREW SM5/16X28 L=19
21	0058	*	*	1	かま押え土台止めねじワッシャー	WASHER
22	1349	*	*	1	かま押え土台板ばね	POSITION SPRING
23	8064	*	*	1	かま押え土台板ばね止めねじ	SCREW SM11/64X40 L=4
24	1347	*	*	1	かま押え	BOBBIN CASE RETAINER
25	1348	*	*	1	かま押えピン	HINGE STUD
26	8009	*	*	1	かま押えピン止めねじ	SCREW SM15/64X28 L=7.5
27	1350	*	*	1	ピン付板ばね	RETAINER SPRING WITH PIN
28	3052	*	*	1	ピン付板ばね止めねじ	SCREW SM9/64X40 L=4.5
29	1531	*	*	1	かま軸ギヤー	HOOK SHAFT GEAR
30	10828-A	*	*	3	かま軸ギヤー止めねじ	SCREW SM1/4X40 L=5
31	1530	*	*	1	かま軸メタル	HOOK SHAFT BUSHING
32	8009	*	*	1	かま軸メタル止めねじ	SCREW SM15/64X28 L=7.5
33	17026	*	*	1	かま軸メタルフェルト	OIL FELT
34	1529	*	*	1	かま軸	HOOK SHAFT
35	1855	*	*	1	かま(組)	ROTATING HOOK AND BOBBIN CASE COMPLETE
36	1855-3C	*	*	1	外かま(組)	ROTATING HOOK COMPLETE
37	1855-8C	*	*	1	内かま(組)	BOBBIN CASE COMPLETE
38	1855-01	*	*	1	外かま土台	ROTATING HOOK BASE
39	1855-02	*	*	3	外かま土台止めねじ	SCREW
40	1855-03	*	*	1	外かま	ROTATING HOOK
41	1855-04	*	*	3	外かま止めねじ	SCREW
42	1855-05	*	*	1	内かま押え	BOBBIN CASE HOLDER
43	1855-06	*	*	1	内かま押えばね	BOBBIN CASE HOLDER SPRING
44	1855-07	*	*	1	内かま押えばね止めねじ	SCREW
45	1855-08	*	*	1	内かま	BOBBIN CASE
46	1855-13	*	*	1	下糸調子ばね	BOBBIN CASE TENSION SPRING
47	1855-14	*	*	1	下糸調子ばね調節ねじ	SCREW
48	1855-15	*	*	1	下糸調子ばね止めねじ	SCREW
49	1441	*	*	1	ボビン	BOBBIN
50	1332	*	*	1	小ギヤー	ARM SHAFT GEAR (SMALL)
51	10828-A	*	*	3	小ギヤー止めねじ	SCREW SM1/4X40 L=5
52	1334	*	*	1	立軸メタル(上)	ARM SHAFT (UPRIGHT) BUSHING (UPPER)
53	1365	*	*	1	立軸メタル(上)止めねじ	SCREW SM15/64X28 L=16
54	1333	*	*	1	立軸	ARM SHAFT (UPRIGHT)
55	1335	*	*	1	立軸メタル(下)	ARM SHAFT (UPRIGHT) BUSHING (LOWER)
56	1365	*	*	1	立軸メタル(下)止めねじ	SCREW SM15/64X28 L=16
57	1336	*	*	1	立軸ギヤー(下)	ARM SHAFT (UPRIGHT) GEAR (LOWER)
58	10828-A	*	*	3	立軸ギヤー(下)止めねじ	SCREW SM1/4X40 L=5

押え棒、針棒、天秤/PRESSER BAR, NEEDLE BAR, THREAD TAKE-UP LEVER

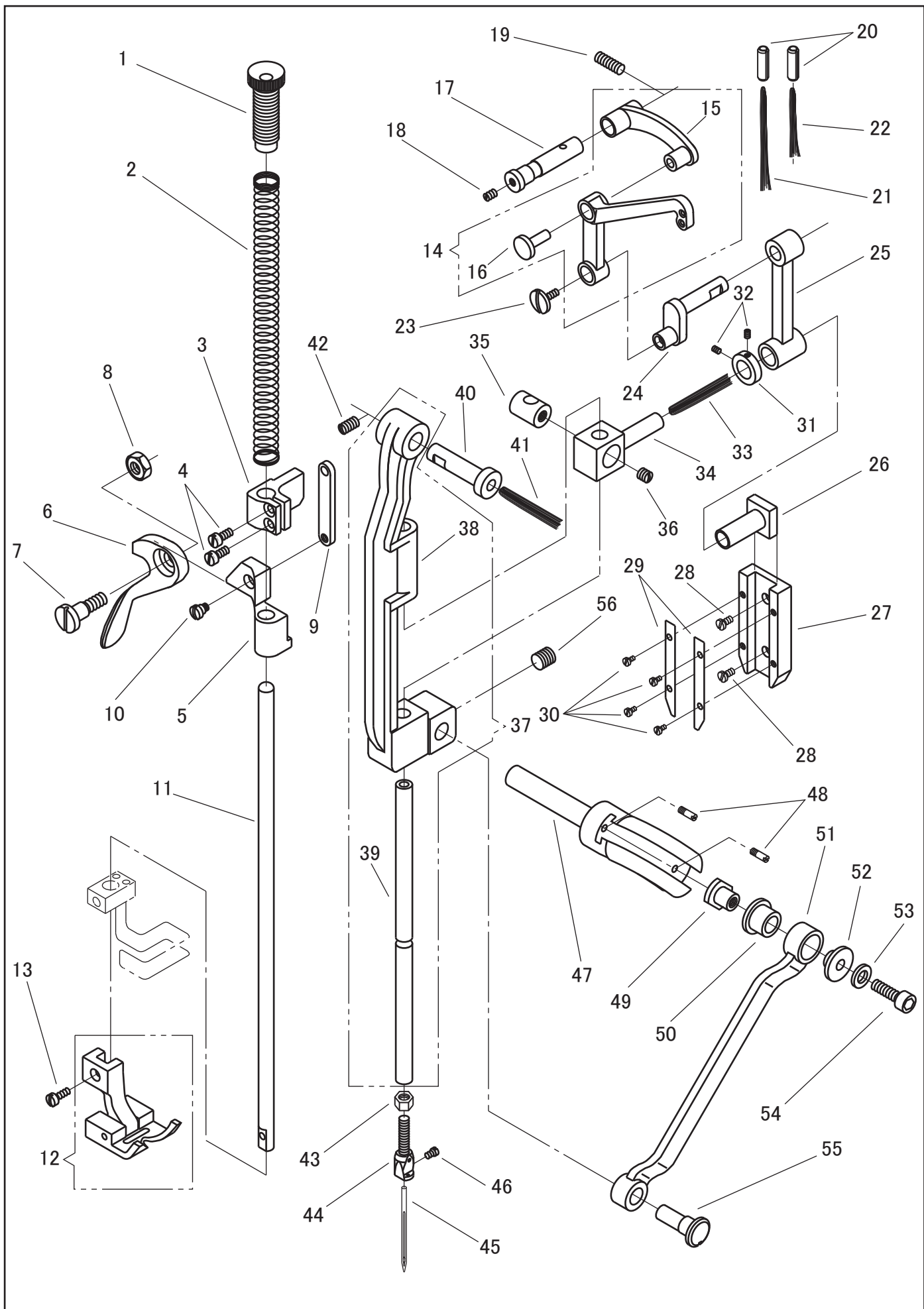

押え棒、針棒、天秤/PRESSER BAR, NEEDLE BAR, THREAD TAKE-UP LEVER

No.	部品番号 PARTS NO.	個 数	個 数	個 数	品名	DESCRIPTION
		個	個	個		
		QTY	QTY	QTY		
1	1402	*	*	1	筒ねじ	PRESSER BAR THUMB SCREW 5/8X28UN
2	1401	*	*	1	押え棒スプリング	PRESSER BAR SPRING
3	1538	*	*	1	押え棒抱き	PRESSER BAR BRACKET
4	50003	*	*	2	押え棒抱き締めねじ	SCREW SM3/16X32 L=10.5
5	1398	*	*	1	押え棒通り抱き	PRESSER BAR BRACKET
6	1409	*	*	1	押え上げレバー	PRESSER BAR LIFTING LEVER
7	1410	*	*	1	押え上げレバー段ねじ	SCREW SM9/32X28
8	8105	*	*	1	押え上げレバー段ねじナット	NUT SM9/32X28
9	1399	*	*	1	短冊メガネ	LIFTING LEVER LINK
10	1400	*	*	1	短冊メガネ止めねじ	SCREW SM3/16X32
11	1393	*	*	1	押え棒	PRESSER BAR
12	1989C	*	*	1	自由押え金(組)	HINGED PRESSER FOOT COMPLETE
13	6025	*	*	1	押え金止めねじ	SCREW SM11/64X40 L=12
14	1534	*	*	1	天秤	THREAD TAKE-UP LEVER
15	1314-01	*	*	1	天秤リンク	THREAD TAKE-UP LEVER LINK
16	1314-02	*	*	1	天秤リンクかしめピン	THREAD TAKE-UP LEVER LINK PIN
17	1315	*	*	1	天秤ピン	THREAD TAKE-UP LEVER PIN
18	2067	*	*	1	天秤ピン油栓ねじ	SCREW SM11/64X40 L=6
19	6046	*	*	1	天秤ピン止めねじ	SCREW SM15/64X28 L=17
20	2092	*	*	2	油パイプ	OIL PIPE
21	1811	*	*	1	天秤油芯(長)	OIL WICK (LONG)
22	3078	*	*	1	天秤油芯(短)	OIL WICK (SHORT)
23	1316	*	*	1	左ねじ	COUNTER-CLOCKWISE SCREW
24	1984	*	*	1	九十度クランク	THREAD TAKE-UP CRANK
25	1812	*	*	1	針棒連結	NEEDLE BAR CONNECTING LINK
26	1813	*	*	1	針棒抱き案内	NEEDLE BAR CONNECTING STUD GUIDE
27	1817-A	*	*	1	案内箱	CRANK GUIDE BLOCK
28	8100	*	*	2	案内箱止めねじ	SCREW SM9/64X40 L=6.5
29	1818	*	*	2	案内板	CRANK GUIDE PLATE
30	8031	*	*	4	案内板止めねじ	SCREW SM3/32X56 L=4
31	1815	*	*	1	針棒クランク振れカラー	NEEDLE BAR CONNECTING CRANK COLLAR
32	1816	*	*	2	針棒クランク振れカラー止めねじ	SCREW M3X0.5 L=4
33	10726	*	*	1	針棒抱き油芯	OIL WICK
34	1814	*	*	1	針棒抱き	NEEDLE BAR CONNECTING STUD
35	1819	*	*	1	針棒固定抱き	NEEDLE BAR HOLDER
36	10658	*	*	1	針棒固定抱き止めねじ	SCREW SM1/4X32 L=5.5
37	1821C	*	*	1	針棒土台・針棒(組)	NEEDLE BAR ROCK FRAME COMPLETE
38	1821	*	*	1	針棒土台	NEEDLE BAR ROCK FRAME
39	1820	*	*	1	針棒	NEEDLE BAR
40	1822-A	*	*	1	針棒土台ピン	NEEDLE BAR ROCK FRAME HINGE STUD
41	10726	*	*	1	針棒土台ピン油芯	OIL WICK
42	6383	*	*	1	針棒土台ピン止めねじ	SCREW SM15/64X28 L=10
43	1825	*	*	1	針株調節ナット	NEEDLE CLAMP ADJUSTING NUT
44	1824-B	*	*	1	針株(2.52)	NEEDLE CLAMP (2.52)
45	N1225	*	*	1	針DDXH14#25	NEEDLE DDXH14 #25
46	10535	*	*	1	針止めねじ	SCREW 3.4X36 L=4.5
47	1837	*	*	1	針振り軸	ZIGZAG ECCENTRIC SHAFT
48	8050	*	*	2	針振り案内駒ストップピンねじ	SCREW SM9/64X40
49	1839	*	*	1	針振り案内駒	ZIGZAG CONNECTING BLOCK
50	1840	*	*	1	針振り案内カラー	ZIGZAG CONNECTION COLLAR
51	1843	*	*	1	揺動連結	ZIGZAG CONNECTION
52	1841	*	*	1	針振り案内カラー段付ワッシャー	ZIGZAG CONNECTION COLLAR WASHER
53	1846	*	*	1	案内駒締めねじワッシャー	WASHER
54	35034	*	*	1	案内駒締めねじ	SCREW M6X1
55	1845	*	*	1	揺動連結段ピン	HINGE PIN
56	11176	*	*	1	揺動連結段ピン止めねじ	SCREW SM7/32X32 L=5.5

針板、送り機構 / THROAT PLATE, FEED MECHANISM

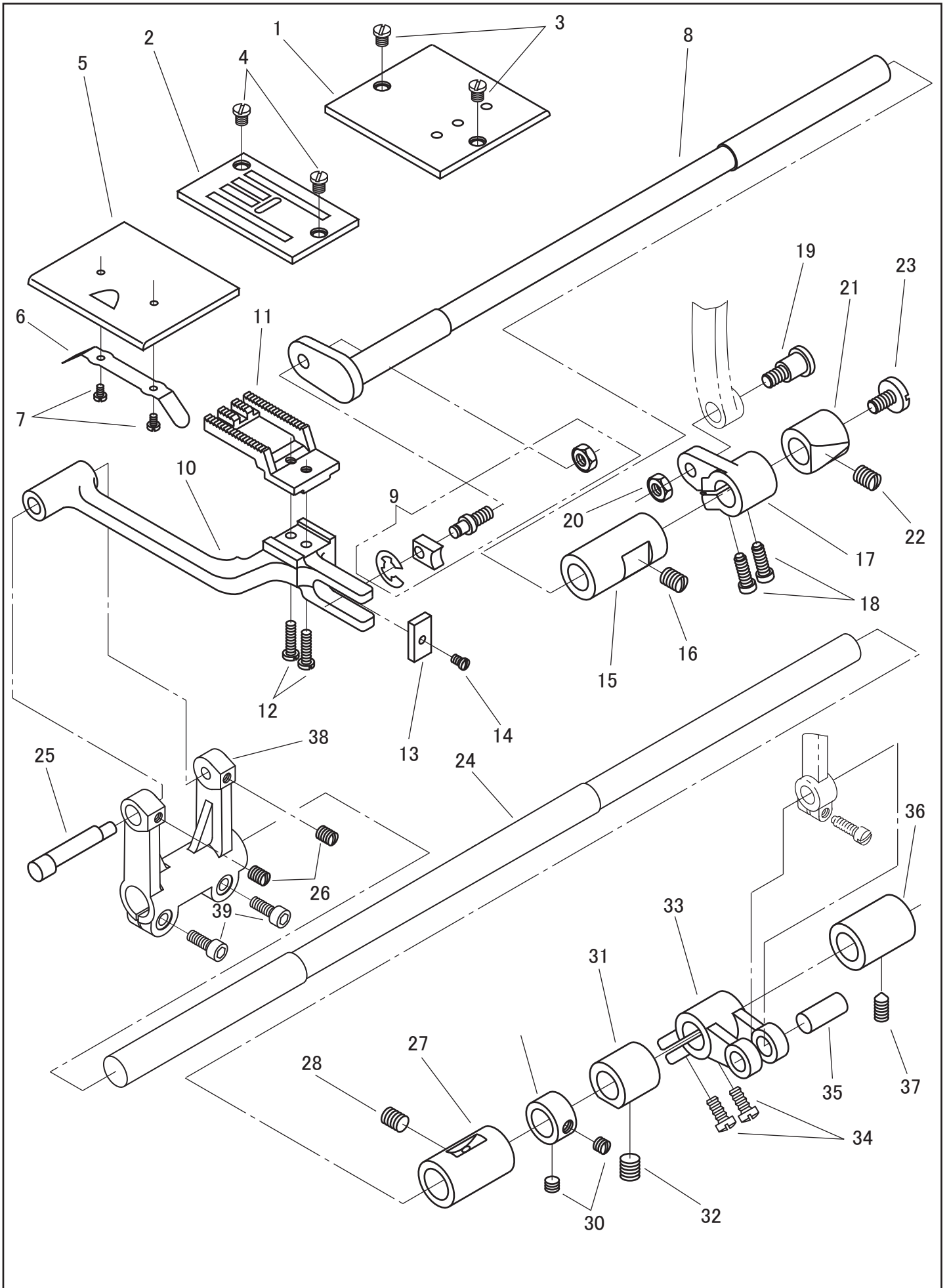

針板、送り機構/THROAT PLATE, FEED MECHANISM

No.	部品番号 PARTS NO.	6B	6B-3	個数 QTY	品名	DESCRIPTION
1	1382	*	*	1	角板(右)	BED SLIDE (RIGHT)
2	1982	*	*	1	針板(4列)	THROAT PLATE (4 ROW)
3	1860	*	*	2	角板(右)止めねじ	SCREW SM3/16X28 L=6
4	1860	*	*	2	針板止めねじ	SCREW SM3/16X28 L=6
5	1545	*	*	1	角板(左)	BED SLIDE (LEFT)
6	1384	*	*	1	角板裏ばね	BED SLIDE SPRING
7	8031	*	*	2	角板裏ばね止めねじ	SCREW SM3/32X56 L=4
8	1512	*	*	1	上下送り軸	FEED LIFTING ROCK SHAFT
9	6007	*	*	1	角玉(ナット付)組	SLIDE BLOCK COMPLETE
10	1863	*	*	1	送り土台	FEED BAR
11	1862	*	*	1	送り歯(四列・千鳥)	FEED DOG (4 ROW)
12	1864	*	*	2	送り歯止めねじ	SCREW SM9/64X40 L=12
13	10596	*	*	1	送り土台フェルト	OIL FELT
14	8031	*	*	1	送り土台フェルト止めねじ	SCREW SM3/32X56 L=4
15	1374	*	*	1	上下送り軸メタル(前)	FEED LIFTING ROCK SHAFT BUSHING (FRONT)
16	6042	*	*	2	上下送り軸メタル(前)止めねじ	SCREW SM5/16X24 L=9
17	1511	*	*	1	上下送り軸クランク	FEED LIFTING ROCK SHAFT CRANK
18	6029	*	*	2	上下送り軸クランク締めねじ	SCREW SM3/16X28
19	1360	*	*	1	上下送り軸クランク段ねじ	SCREW SM9/32X28
20	8105	*	*	1	上下送り軸クランク段ねじナット	NUT SM9/32X28
21	1375	*	*	1	上下送り軸メタル(後)	FEED LIFTING ROCK SHAFT BUSHING (BACK)
22	6042	*	*	2	上下送り軸メタル(後)止めねじ	SCREW SM5/16X24 L=9
23	1368	*	*	1	上下送り軸振れ止めめじ	SCREW SM1/4X40 L=11
24	1948	*	*	1	送り軸	FEED ROCK SHAFT
25	1516	*	*	1	送り土台ピン	FEED BAR HINGE PIN
26	11176	*	*	2	送り土台ピン止めねじ	SCREW SM7/32X32 L=5.5
27	1514	*	*	1	送り軸メタル(前)	FEED ROCK SHAFT BUSHING (FRONT)
28	1327	*	*	1	送り軸メタル(前)止めねじ	SCREW SM5/16X24 L=13
29	10593	*	*	1	送り軸カラー	ROCK SHAFT STOP COLLAR
30	10764	*	*	2	送り軸カラー止めねじ	SCREW 6.75X24 L=4.5
31	1375	*	*	1	送り軸メタル(中)	FEED ROCK SHAFT BUSHING (MIDDLE)
32	1327	*	*	1	送り軸メタル(中)止めねじ	SCREW SM5/16X24 L=13
33	1734	*	*	1	送り軸クランク	FEED ROCK SHAFT CRANK
34	1365	*	*	2	送り軸クランク締めねじ	SCREW SM15/64X28 L=16
35	1736	*	*	1	立ロッド(下)ピン	PIN
36	1367	*	*	1	送り軸メタル(後)	FEED ROCK SHAFT BUSHING (REAR)
37	1327	*	*	1	送り軸メタル(後)止めねじ	SCREW SM5/16X24 L=13
38	1947	*	*	1	送り軸腕	FEED ROCK SHAFT ARM
39	18065	*	*	2	送り軸腕止めねじ	SCREW M5X0.8 L=14

糸調子、弓/THREAD TENSION, FOOT LIFTING LEVER

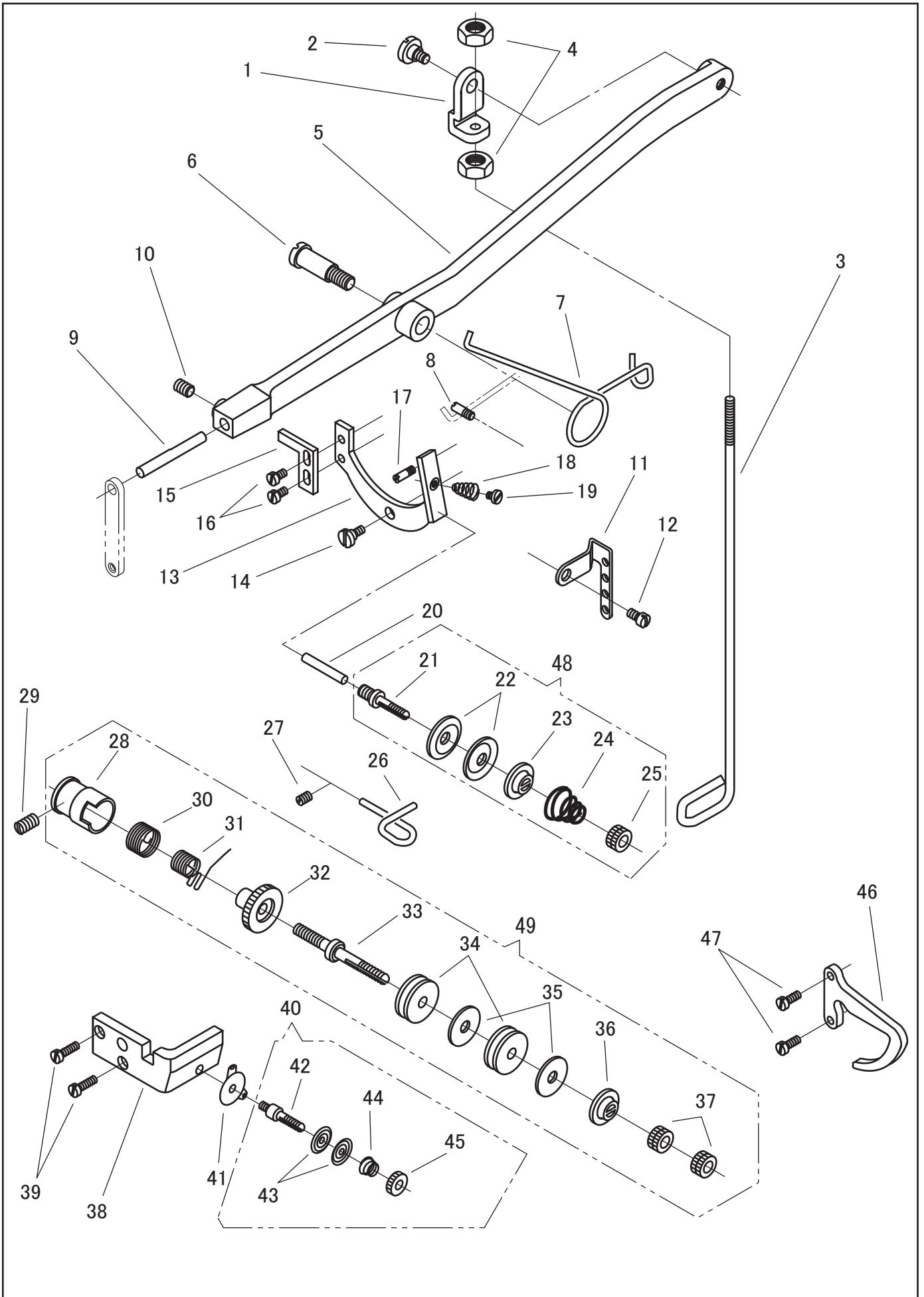

糸調子、弓/THREAD TENSION, FOOT LIFTING LEVER

No.	部品番号 PARTS NO.	6B	6B-3	個数 QTY	品名	DESCRIPTION
1	6359-A	*	*	1	吊り棒だるま	FOOT LIFTING LEVER CONNECTING ROD JOINT
2	6384	*	*	1	吊り棒だるま段ねじ	SCREW SM15/64X28
3	1433	*	*	1	吊り棒	FOOT LIFTING LEVER CONNECTING ROD
4	6360	*	*	2	吊り棒ナット	NUT SM3/16X32
5	1431	*	*	1	弓	FOOT LIFTING LEVER
6	8086-01	*	*	1	弓止めねじ(黒)	SCREW SM5/16X24
7	1432	*	*	1	弓ばね	FOOT LIFTING LEVER SPRING
8	8050	*	*	1	弓ばね受ねじ	SCREW SM9/64X40
9	2068	*	*	1	弓先棒	FOOT LIFTING LEVER PIN
10	8009	*	*	1	弓先棒止めねじ	SCREW SM15/64X28 L=7.5
11	1895	*	*	1	糸掛(A)	THREAD GUIDE (A)
12	20048	*	*	1	糸掛(A)止めねじ	SCREW SM7/32X32
13	1852	*	*	1	皿浮かし	TENSION RELEASE LEVER
14	10704	*	*	1	皿浮かし段ねじ	SCREW SM3/16X28
15	1562	*	*	1	皿浮かし補助	THREAD RELEASE LEVER SUPPORT
16	3052	*	*	2	皿うかし補助止めねじ	SCREW SM9/64X40 L=4.5
17	8050	*	*	1	皿浮かしストップピンねじ	SCREW SM9/64X40
18	1413	*	*	1	皿浮かしスプリング	SPRING
19	8111	*	*	1	皿浮かしスプリング止めねじ	SCREW SM1/8X44 L=1.8
20	1853	*	*	1	皿浮かしピン	TENSION RELEASE PIN
21	50262	*	*	1	糸調子棒(上)	TENSION SCREW STUD (UPPER)
22	8077	*	*	2	糸調子皿(上)	TENSION DISC (UPPER)
23	3071	*	*	1	丸一皿	TENSION RELEASE WASHER
24	8078	*	*	1	渦巻ばね	SPIRAL SPRING
25	8079	*	*	1	ローレットナット	TENSION THUMB NUT
26	1778	*	*	1	糸掛(B)	THREAD GUIDE (B)
27	2067	*	*	1	糸掛(B)止めねじ	SCREW SM11/64X40 L=6
28	1414	*	*	1	糸調子臼	THREAD TAKE-UP SPRING REGULATOR
29	6383	*	*	1	糸調子臼止めねじ	SCREW SM15/64X28 L=10
30	1417	*	*	1	補助スプリング	REGULATING SPRING
31	1542	*	*	1	糸取りスプリング	THREAD TAKE-UP SPRING
32	1418	*	*	1	スプリング調節	THREAD TAKE-UP SPRING ADJUSTING SLEEVE
33	1415	*	*	1	糸調子棒(下)	TENSION SCREW STUD (LOWER)
34	1543	*	*	2	糸調子皿(下)	TENSION DISC (LOWER)
35	35164	*	*	2	糸調子皿皮	TENSION DISC LEATHER
36	3071	*	*	1	丸一皿	TENSION RELEASE WASHER
37	8079	*	*	2	ローレットナット	TENSION THUMB NUT
38	1823	*	*	1	針棒土台振れ止板	NEEDLE BAR ROCK FRAME GUIDE
39	11073	*	*	2	針棒土台振れ止め板止めねじ	SCREW SM11/64X32 L=11
40	20223C	*	*	1	補助糸調子組	AUXILIARY TENSION REGULATOR COMPLETE
41	38014	*	*	1	補助糸調子糸掛	AUXILIARY TENSION REGULATOR THREAD GUIDE
42	20223	*	*	1	補助糸調子棒	AUXILIARY TENSION SCREW STUD
43	20224	*	*	2	補助糸調子皿	AUXILIARY TENSION DISC
44	20226-01	*	*	1	渦巻スプリング	AUXILIARY TENSION REGULATOR SPIRAL SPRING
45	20225	*	*	1	補助糸調子ナット	AUXILIARY TENSION THUMB NUT
46	1854	*	*	1	糸掛(C)	THREAD GUIDE (C)
47	8040	*	*	2	糸掛(C)止めねじ	SCREW SM9/64X40
48	1857C	*	*	1	糸調子棒(上)組	TENSION SCREW STUD (UPPER) COMPLETE
49	1543C	*	*	1	糸調子皿(下)組	TENSION DISC (LOWER) COMPLETE

返し機構/FEED REVERSING MECHANISM

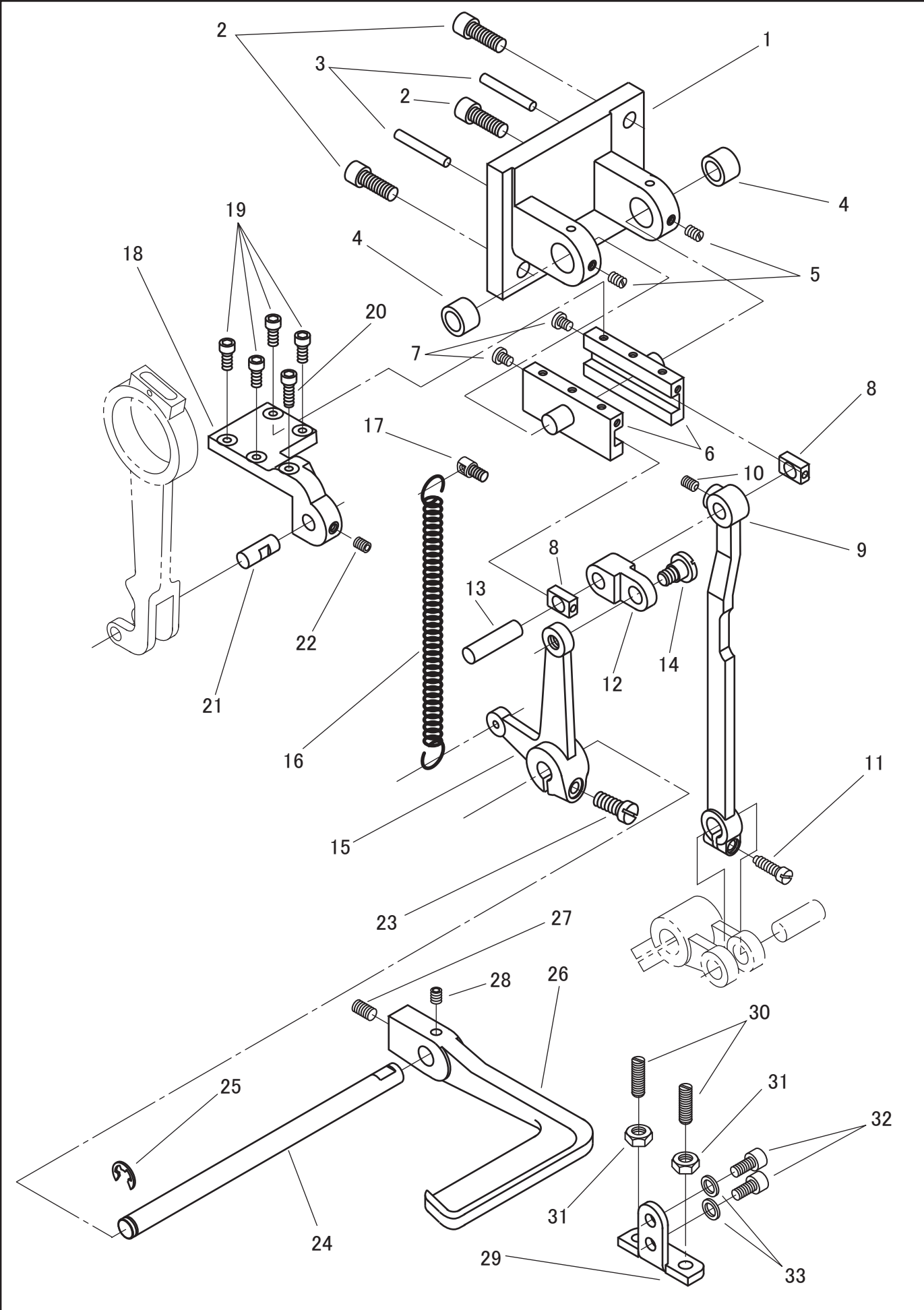

返し機構/FEED REVERSING MECHANISM

No.	部品番号 PARTS NO.	6B	6B-3	個数 QTY	品名	DESCRIPTION
1	1723	*	*	1	案内レール土台	SLIDE BLOCK GUIDE BASE
2	35034	*	*	3	案内レール土台止めねじ	SCREW M6X1
3	8023-A	*	*	2	案内レール土台ノックピン	TAPER PIN (3.5 X 25)
4	20105-A	*	*	2	ベアリング	BEARING
5	2067	*	*	2	案内レールベアリング止めねじ	SCREW SM11/64X40 L=6
6	1730	*	*	2	案内レール	SLIDE BLOCK GUIDE
7	4094	*	*	2	角玉ストッパー止めねじ	SCREW M4X0.7 L=5
8	34012	*	*	2	バック角玉	FEED REVERSING SLIDE BLOCK
9	1733	*	*	1	立ロッド(下)	FEED ROCK SHAFT CONNECTING ROD (LOWER)
10	27170	*	*	1	角玉ピン止めねじ	SCREW M5X0.8 L=6
11	6029	*	*	1	立ロッド(下)締めねじ	SCREW SM3/16X28
12	1769	*	*	1	バックリンク	FEED REVERSING CONNECTING LINK
13	1732	*	*	1	角玉ピン	CONNECTION PIN
14	1770	*	*	1	バックリンク段ねじ	HINGE SCREW 15/64X28
15	1768	*	*	1	バック駆動連結	FEED REVERSING LEVER SHAFT CRANK
16	1771	*	*	1	バックスプリング	FEED REVERSING LEVER SPRING
17	1772	*	*	1	バックスプリング掛	FEED REVERSING LEVER SPRING HOOK
18	1729	*	*	1	案内レール押え板	SLIDE BLOCK GUIDE PLATE
19	31092	*	*	4	案内レール押え板締めねじ(短)	SCREW M4X0.7
20	29056	*	*	1	案内レール押え板締めねじ(長)	SCREW M4X0.7
21	1728	*	*	1	立ロッド(上)ピン	PIN
22	27170	*	*	1	立ロッド(上)ピン止めねじ	SCREW M5X0.8 L=6
23	1774	*	*	1	バック駆動連結締めねじ	SCREW SM3/16X28 L=13
24	1986	*	*	1	バックレバー軸	FEED REVERSING LEVER SHAFT
25	11426	*	*	1	バックレバー軸止め輪	RETAINING RING: E TYPE
26	1987	*	*	1	バックレバー	FEED REVERSING LEVER
27	28043	*	*	1	バックレバー止めねじ(B)	SCREW M6X1 L=10
28	27170	*	*	1	バックレバー止めねじ(A)	SCREW M5X0.8 L=6
29	1988	*	*	1	バックレバーストップ	FEED REVERSING LEVER STOPPER
30	10576	*	*	2	バックレバーストップねじ	SCREW SM15/64X28 L=21
31	50409	*	*	2	バックレバーストップナット	NUT SM15/64X28
32	30066	*	*	2	バックレバーストップ止めねじ	SCREW M5X0.8
33	90625	*	*	2	バックレバーストップ止めねじワッシャー	WASHER

ベルトガード/BELT GUARD

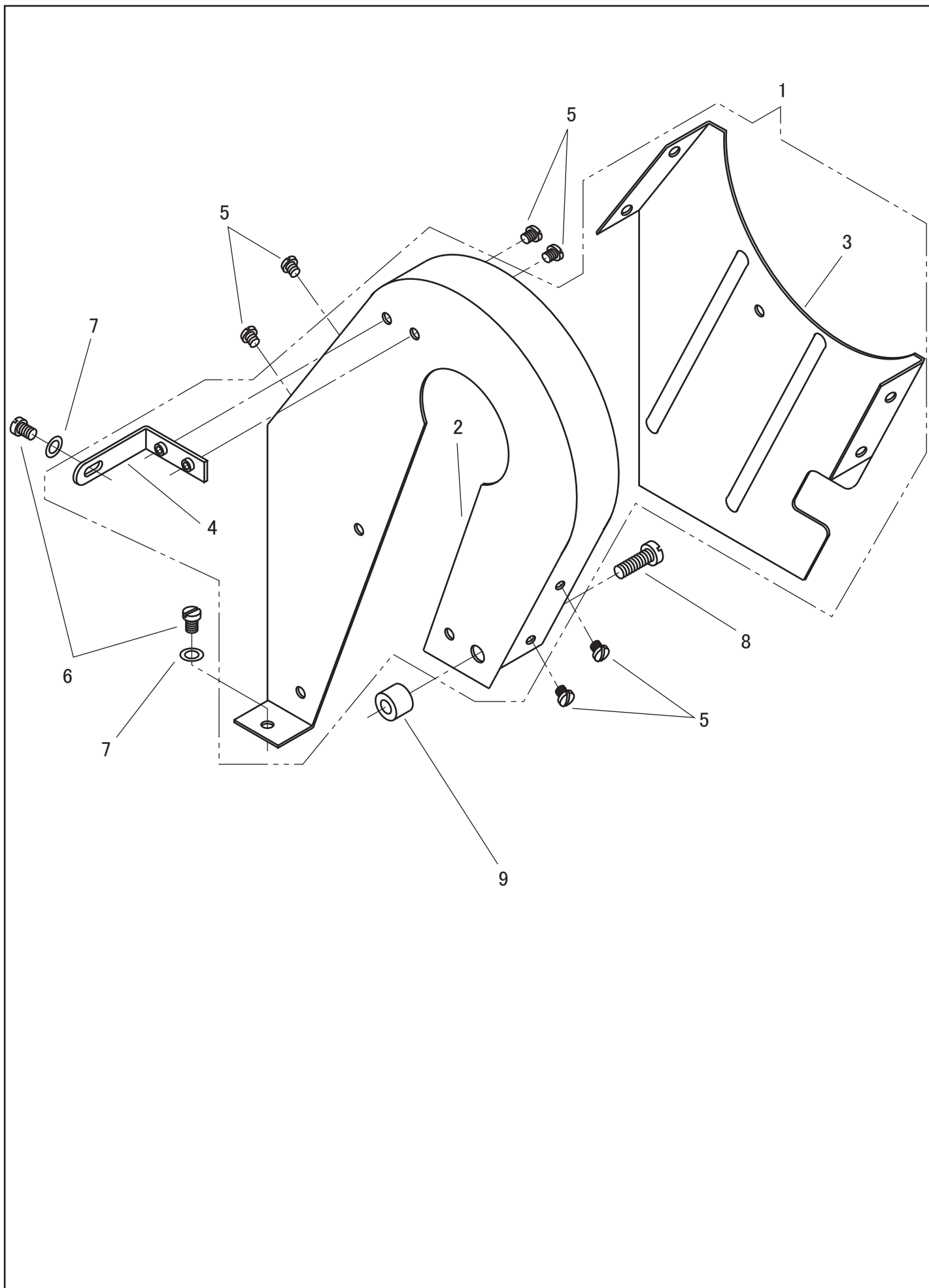

ベルトガード/BELT GUARD

No.	部品番号 PARTS NO.	6B	6B-3	個数 QTY	品名	DESCRIPTION
1	1995C	*	*	1	ベルトガード(組)	BELT GUARD COMPLETE
2	1995	*	*	1	ベルトガード	BELT GUARD BODY
3	1874	*	*	1	ベルトガード横カバー	BELT GUARD SIDE COVER
4	1875	*	*	1	ベルトガード取付板	BELT GUARD STAY
5	6339	*	*	6	ベルトガード止めねじ	SCREW SM1/8X44 L=4
6	20276	*	*	2	ベルトガード取付ねじ(小)	SCREW SM3/16X30 L=7
7	16287	*	*	2	ベルトガード取付ねじワッシャー	WASHER
8	37304	*	*	1	ベルトガード取付ねじ(大)	SCREW M6X1 L=20
9	37301	*	*	1	ベルトガードカラー	BELT GUARD COLLAR

針振りギヤー、上板/ZIGZAG GEAR, ARM TOP COVER
SKZ-6B

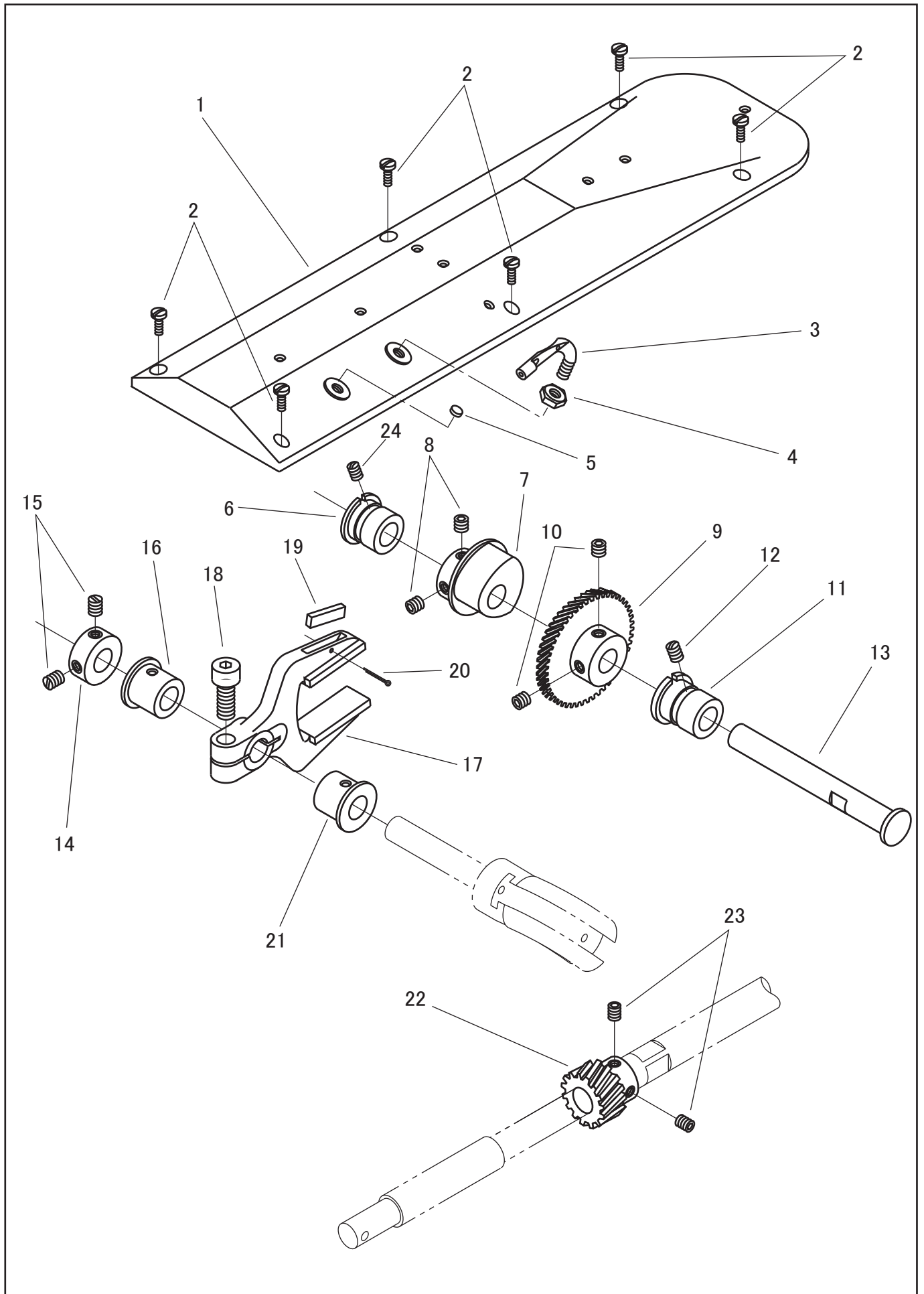

針振りギヤー、上板/ZIGZAG GEAR, ARM TOP COVER
SKZ-6B

No.	部品番号 PARTS NO.	6B	個数 QTY	品名	DESCRIPTION
1	1805	*	1	上板	ARM TOP COVER
2	15007	*	6	上板止めねじ	SCREW SM9/64X40
3	11006	*	1	上板糸掛	ARM TOP COVER THREAD GUIDE
4	13076-02	*	1	上板糸掛ナット	NUT SM7/32X32
5	15038	*	1	上板ゴム栓	FACE PLATE RUBBER
6	1961	*	1	針振ギヤー軸メタル(後)	ZIGZAG SHAFT BUSHING (BACK)
7	1834	*	1	針振りカム	ZIGZAG ECCENTRIC
8	10766-G	*	2	針振りカム止めねじ	SCREW SM1/4X32 L=7
9	1830-A	*	1	針振り大ギヤー	ZIGZAG GEAR (LARGE)
10	10766-G	*	2	針振り大ギヤー止めねじ	SCREW SM1/4X32 L=7
11	1960	*	1	針振ギヤー軸メタル(前)	ZIGZAG SHAFT BUSHING (FRONT)
12	8009	*	1	針振ギヤー軸メタル(前)止めねじ	SCREW SM15/64X28 L=7.5
13	1831	*	1	針振ギヤー軸	ZIGZAG GEAR SHAFT
14	1838	*	1	針振り軸カラー	ZIGZAG ECCENTRIC SHAFT COLLAR
15	10766	*	2	針振り軸カラー止めねじ	SCREW SM1/4X32 L=7
16	1833	*	1	針振り軸メタル(後)	ZIGZAG ECCENTRIC SHAFT BUSHING (BACK)
17	1835	*	1	針振りニ又	ZIGZAG ECCENTRIC FORK
18	27181	*	1	針振りニ又締めねじ	SCREW M8X1.25
19	17026	*	1	針振ニ又フェルト	OIL FELT
20	10620	*	1	フェルト止め割りピン	COTTER PIN
21	1833	*	1	針振り軸メタル(前)	ZIGZAG ECCENTRIC SHAFT BUSHING (FRONT)
22	1829-A	*	1	針振り小ギヤー	ZIGZAG GEAR (SMALL)
23	10766-G	*	2	針振り小ギヤー止めねじ	SCREW SM1/4X32 L=7
24	2067	*	1	針振ギヤー軸メタル(後)止めねじ	SCREW SM11/64X40 L=6

針振りギヤー、上板/ZIGZAG GEAR, ARM TOP COVER
SKZ-6B-3

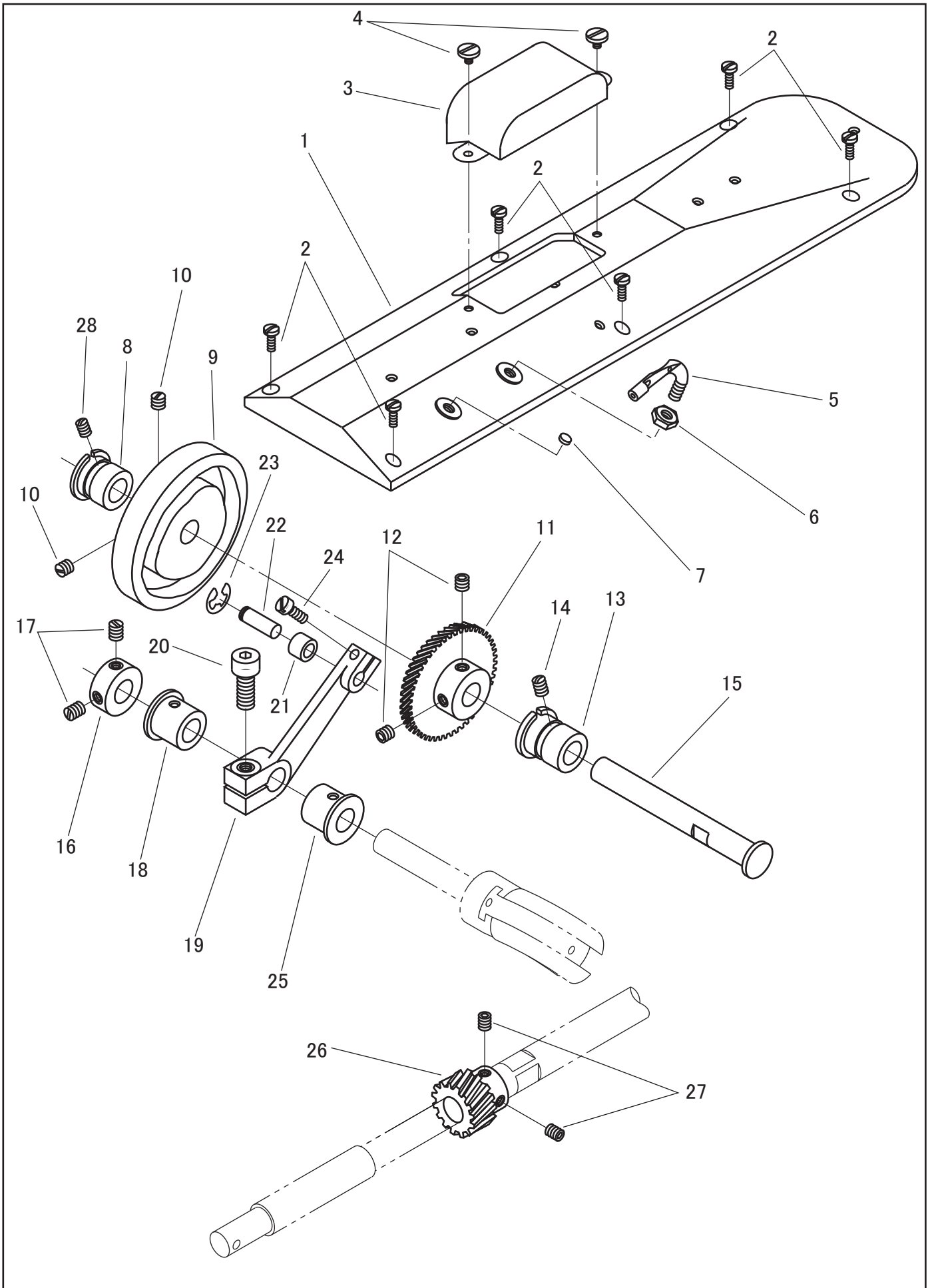

針振りギヤー、上板/ZIGZAG GEAR, ARM TOP COVER
SKZ-6B-3

No.	部品番号 PARTS NO.	3 B	個数 QTY	品名	DESCRIPTION
1	1954	*	1	上板	ARM TOP COVER
2	15007	*	6	上板止めねじ	SCREW SM9/64X40
3	1955	*	1	上板カバー	AUXILIARY ARM TOP COVER
4	2031	*	2	上板カバー止めねじ	SCREW SM9/64X40 L=5
5	11006	*	1	上板糸掛	ARM TOP COVER THREAD GUIDE
6	13076-02	*	1	上板糸掛ナット	NUT SM7/32X32
7	15038	*	1	上板ゴム栓	FACE PLATE RUBBER
8	1961	*	1	針振りギヤー軸メタル(後)	ZIGZAG SHAFT BUSHING (BACK)
9	1951	*	1	針振りカム	ZIGZAG ECCENTRIC
10	10639	*	2	針振りカム止めねじ	SCREW SM1/4X32 L=8
11	1956	*	1	針振り大ギヤー	ZIGZAG GEAR (LARGE)
12	10766-G	*	2	針振り大ギヤー止めねじ	SCREW SM1/4X32 L=7
13	1960	*	1	針振りギヤー軸メタル(前)	ZIGZAG SHAFT BUSHING (FRONT)
14	8009	*	1	針振りギヤー軸メタル(前)止めねじ	SCREW SM15/64X28 L=7.5
15	1831	*	1	針振りギヤー軸	ZIGZAG GEAR SHAFT
16	1838	*	1	針振り軸カラー	ZIGZAG ECCENTRIC SHAFT COLLAR
17	10766	*	2	針振り軸カラー止めねじ	SCREW SM1/4X32 L=7
18	1833	*	1	針振り軸メタル(後)	ZIGZAG ECCENTRIC SHAFT BUSHING (BACK)
19	1952	*	1	針振り連結	ZIGZAG ECCENTRIC CONNECTION
20	27181	*	1	針振り連結締めねじ	SCREW M8X1.25
21	1959	*	1	針振りローラー	ZIGZAG ECCENTRIC CONNECTION ROLLER
22	1953	*	1	針振りローラーピン	ZIGZAG ECCENTRIC CONNECTION ROLLER PIN
23	4839	*	1	ローラー止め輪	RETAINING RING: E TYPE
24	6323	*	1	針振りローラーピン締めねじ	SCREW SM3/16X32 L=14.5
25	1833	*	1	針振り軸メタル(前)	ZIGZAG ECCENTRIC SHAFT BUSHING (FRONT)
26	1957	*	1	針振り小ギヤー	ZIGZAG GEAR (SMALL)
27	10766-G	*	2	針振り小ギヤー止めねじ	SCREW SM1/4X32 L=7
28	2067	*	1	針振りギヤー軸メタル(後)止めねじ	SCREW SM11/64X40 L=6

付属品1/ACCESSORIES 1

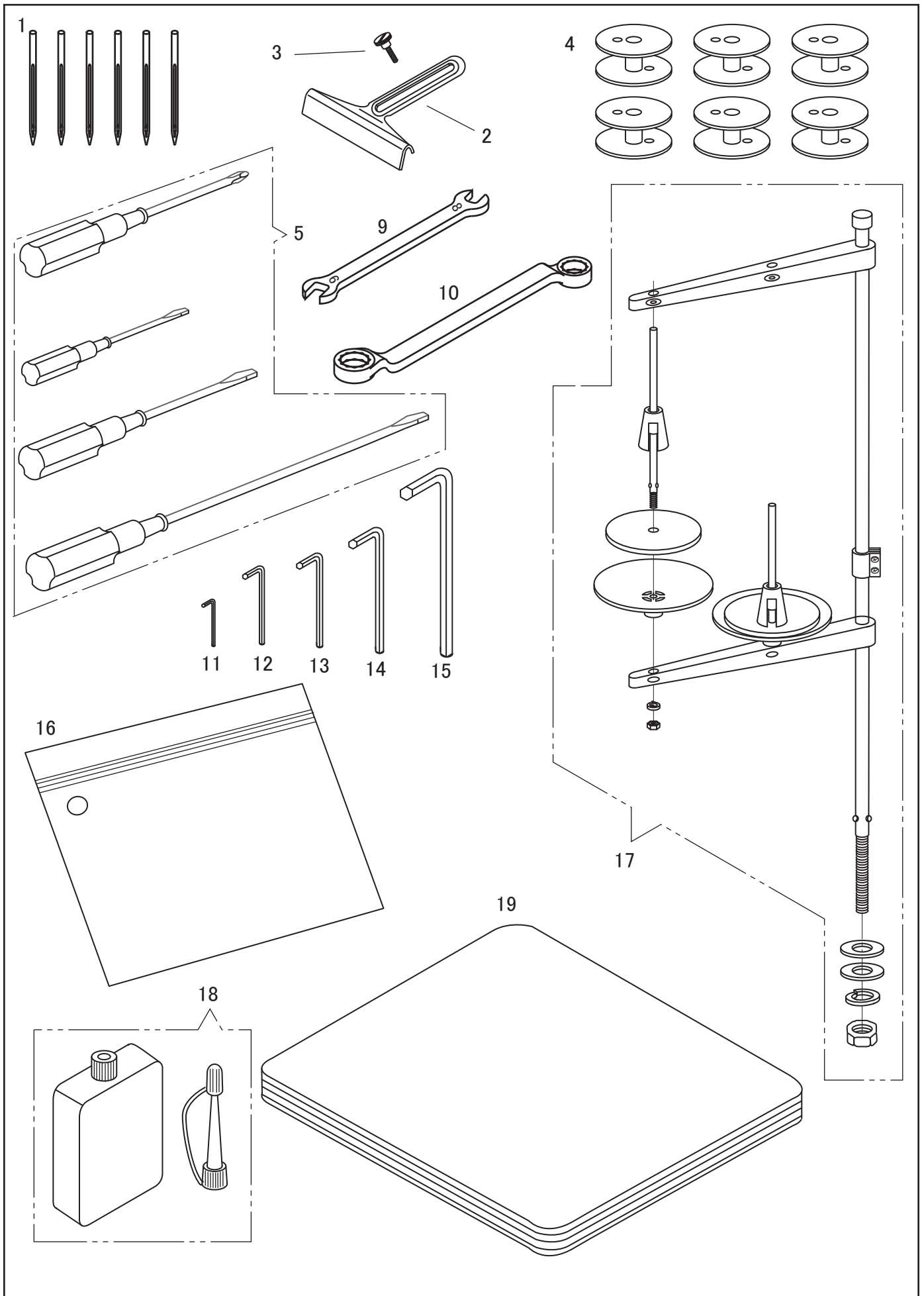

付属品1/ACCESSORIES 1

No.	部品番号 PARTS NO.	品	個数 QTY	品名	DESCRIPTION
1	N1225	*	6	針DDXH14#25	NEEDLE DDXH14 #25
2	6050	*	1	定規	CLOTH EDGE GUIDE
3	7047	*	1	定規止めねじ	SCREW SM9/64X40
4	1441	*	6	ボビン	BOBBIN
5	25649C	*	1	ドライバー4点組	SCREW DRIVER COMPLETE
9	4202	*	1	スパナ	SPANNER (9 X 8)
10	19462	*	1	メガネレンチ	DOUBLE HEAD WRENCH
11	1872	*	1	六角レンチ(1.5MM)	HEXAGONAL WRENCH (1.5MM)
12	19457	*	1	六角レンチ(2.5MM)	HEXAGONAL WRENCH (2.5MM)
13	19458	*	1	六角レンチ(3MM)	HEXAGONAL WRENCH (3MM)
14	19459	*	1	六角レンチ(4MM)	HEXAGONAL WRENCH (4MM)
15	1871	*	1	六角レンチ(6MM)	HEXAGONAL WRENCH (6MM)
16	8132-A	*	1	部品袋	ACCESSORY BAG
17	35254	*	1	糸立セット	THREAD STAND COMPLETE
18	8123	*	1	油	OILER
19	8124	*	1	ビニールカバー(大)	VINYL COVER

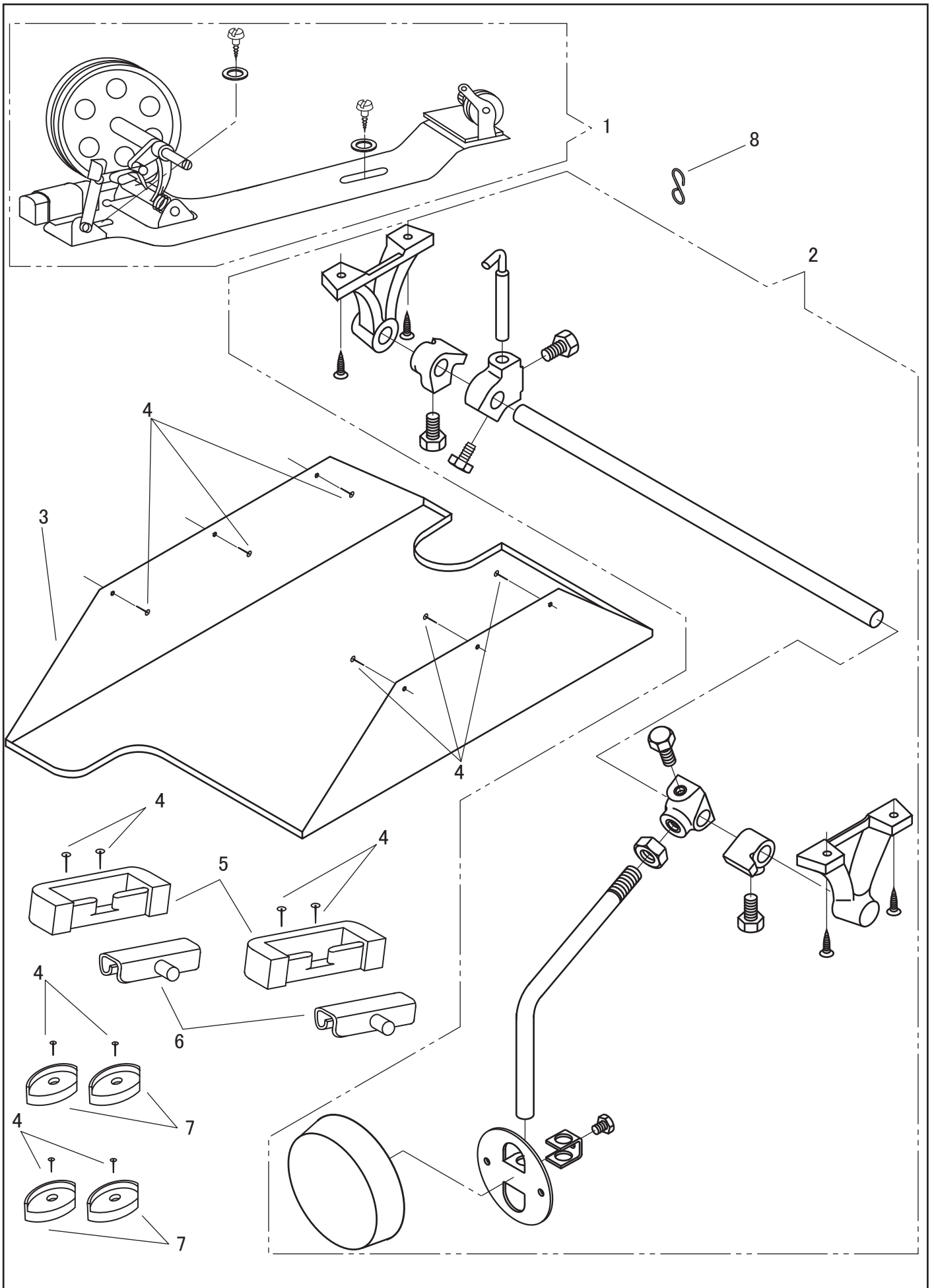

付属品2/ACCESSORIES 2

No.	部品番号 PARTS NO.	6B	6B-3	個数 QTY	品名	DESCRIPTION
1	1440	*	*	1	糸巻セット	BOBBIN WINDER COMPLETE
2	1552	*	*	1	ひざ上げセット	KNEE LIFTER COMPLETE
3	1553	*	*	1	油受	OIL PAN
4	6055	*	*	14	止釘	NAIL
5	11886	*	*	2	ヒンジ受ゴム	HINGE RUBBER CUSHION
6	11885	*	*	2	ヒンジ	HINGE CONNECTION
7	11887	*	*	4	コーナーゴム	CORNER RUBBER CUSHION
8	25675-02	*	*	1	フック	HOOK

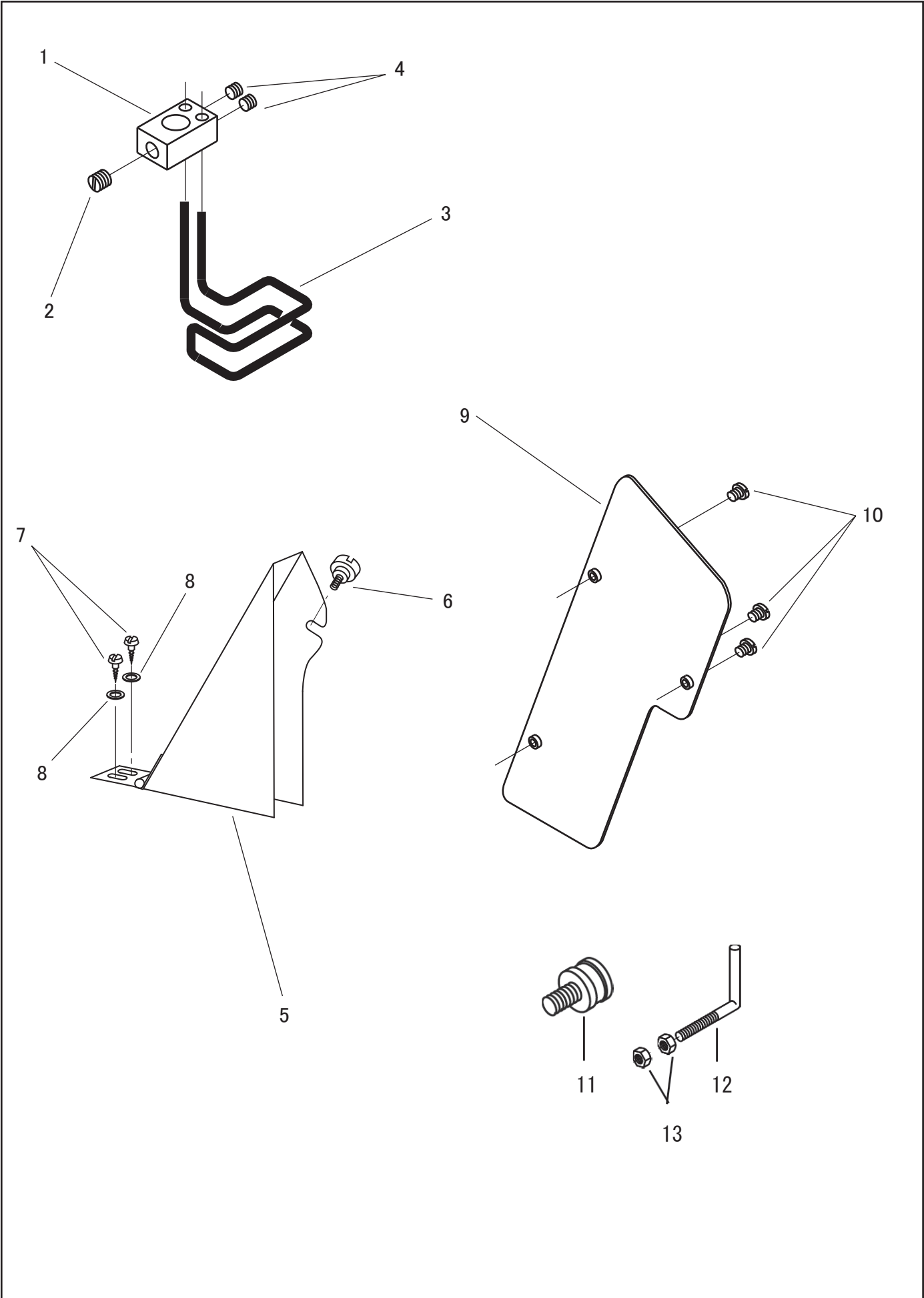

別売品/OPTION



別売品/OPTION

No.	部品番号 PARTS NO.	6B	6B-3	個数 QTY	品名	DESCRIPTION
1	35245	*	*	1	フィンガーガード取付台	FINGER GUARD BASE
2	8097	*	*	1	フィンガーガード取付台止めねじ	SCREW SM15/64X28 L=5
3	1897	*	*	1	フィンガーガード	FINGER GUARD
4	8103	*	*	2	フィンガーガード止めねじ	SCREW SM11/64X40 L=3.5
5	1458	*	*	1	補助ベルトガード(組)	AUXILIARY BELT GUARD COMPLETE
6	11830	*	*	1	補助ベルトガード止めねじ	SCREW 9/64X40
7	15081	*	*	2	補助ベルトガード木ねじ	WOOD SCREW
8	16287	*	*	2	補助ベルトガード木ねじワッシャー	WASHER
9	1996	*	*	1	ベルトガード補助板	BELT GUARD AUXILIARY PLATE
10	6339	*	*	3	ベルトガード補助板止めねじ	SCREW SM1/8X44 L=4
11	MH-001	*	*	1	検出器アダプター	SYNCHRONIZER ADAPTOR
12	17529	*	*	1	検出器支え棒	SYNCHRONIZER SUPPORT
13	37102	*	*	2	ナットM6	NUT M6

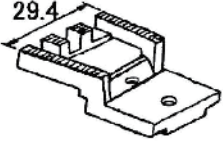
ゲージ表 / TABLE OF GAUGE PARTS

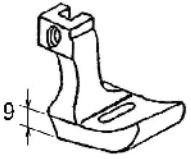
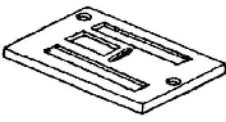
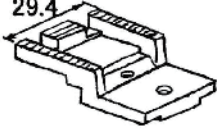
	針板 THROTE PLATE	送り歯 FEED DOG	自由押え HINGED PRESSER FOOT	*1 固定押え PRESSER FOOT
標準 STANDARD 4枚歯 4 TEETH	 1982	 29.4 1862	標準 STANDARD  32 1989C	オプション OPTION  9 1884
3枚歯 3 TEETH	 1878	 29.4 1881		

*1 本部品はロープ縫いなどの用途に溝を加工して使います。
This parts is used by machining a groove for applications such as rope sewing.

SEIKO SEWING MACHINE CO., LTD.

2-13-6 Sakaecho, Funabashi-shi Chiba Prefecture,
273-0018, Japan

TEL: 81-47-420-3561 (Overseas dept.)

FAX: 81-47-420-3560

E-mail: export@seiko-sewing.co.jp

<http://www.seiko-sewing.co.jp/>

セイコーミシン株式会社

〒273-0018 千葉県船橋市栄町2-13-6

TEL: 047-420-3561, IP電話: 050-3535-3491

FAX: 047-420-3560

E-mail: eigy@seiko-sewing.co.jp

(国内営業)

Parts No. PB29500 (1219)

Rev. 3.1