

膝スイッチ関係(-FL)/Knee switch mechanism (-FL)

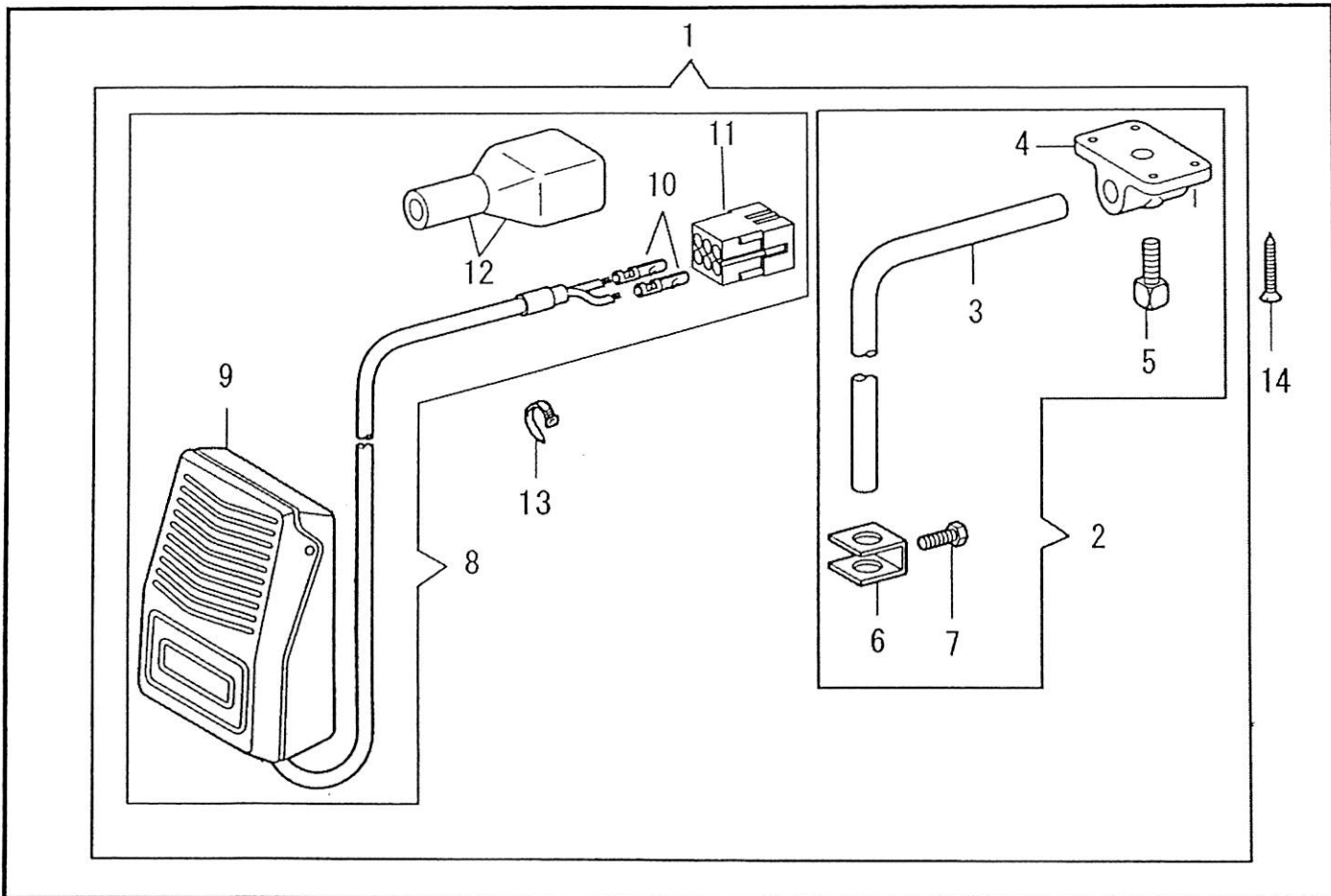

手動スイッチ関係(-BT, -CD, -DS)/Manual switch mechanism (-BT, -CD, -DS)

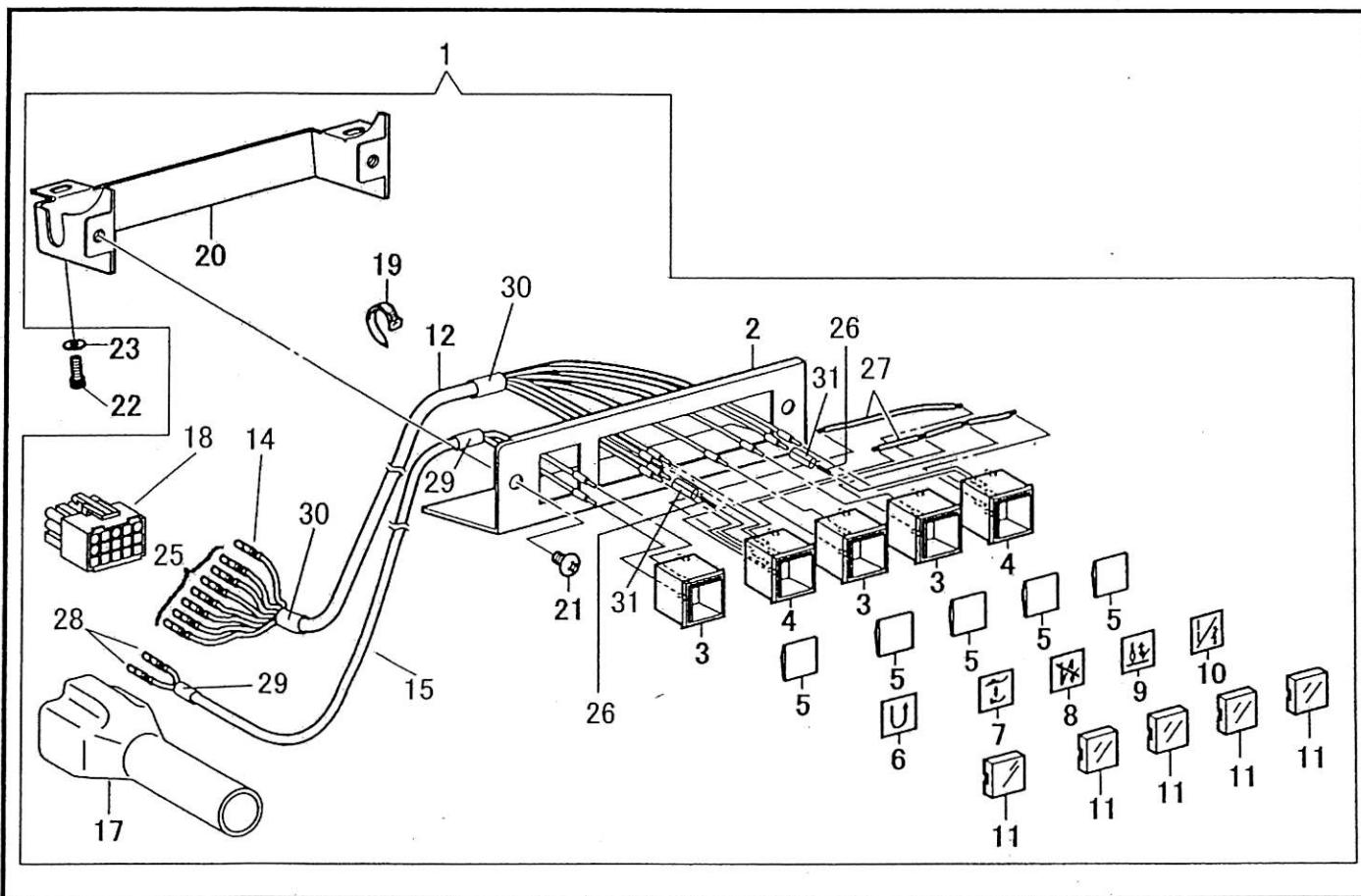

膝スイッチ関係(-FL)/Knee switch mechanism (-FL)

NO.	部品番号	-8BL	-28BL	-8BLC	-28BLC	-8BLC-BTFL- CD-DS/ -28BLC- BTFL-CD-DS	数量	品名	DESCRIPTION
	PARTS NO.						QTY		
1	60541C	-	-	-	-	*	1	膝スイッチセット	KNEE SWITCH ASSY
2	B142026C	-	-	-	-	*	1	スイッチ取付け棒(組)	KNEE SWITCH SHAFT ASSY
3	B142026	-	-	-	-	*	1	スイッチ取付け棒	KNEE SWITCH SHAFT
4	B142027	-	-	-	-	*	1	スイッチ取付け棒台	BRACKET, :SHAFT
5	B100463	-	-	-	-	*	1	スイッチ取付け棒止めねじ	BOLT, SQUARE 7.94X18 L=13.5
6	B114967	-	-	-	-	*	1	スイッチ取付け棒ストッパー	STOPPER, :K-LIFTER PLATE
7	B110087	-	-	-	-	*	1	スイッチ取付け棒止	BOLT 5.95X28 L=8
8	60541	-	-	-	-	*	1	膝スイッチ(組)	SWITCH & CONNECTOR ASSY
9	60541-03	-	-	-	-	*	1	膝スイッチ・取付け板(組)	SWITCH & SETTING PLATE ASSY
10	30187	-	-	-	-	*	2	コネクタピン	PIN CONTACT
11	30185	-	-	-	-	*	1	コネクタ(P) 6P	NYLON CONNECTOR
12	30151	-	-	-	-	*	1	コネクタカバー 6P	PLUG COVER, #14
13	30750	-	-	-	-	*	1	結束バンド	BEAD BAND, S
14	40253	-	-	-	-	*	4	膝スイッチ取付け木ねじ	WOOD SCREW, FLAT M4.1X25

手動スイッチ関係(-BT, -CD, -DS)/Manual switch mechanism (-BT, -CD, -DS)

NO.	部品番号	-8BL	-28BL	-8BLC	-28BLC	-8BLC-BTFL- CD-DS/ -28BLC- BTFL-CD-DS	数量	品名	DESCRIPTION
	PARTS NO.						QTY		
1	60473C	-	-	-	-	*	1	スイッチセット	SWITCH COMPLETE
2	60177	-	-	-	-	*	1	スイッチカバー	SWITCH COVER
3	60175	-	-	-	-	*	3	スイッチ(UB-15KKS1N)	SWITCH, UB-15KKS1N
4	60176	-	-	-	-	*	2	スイッチ(UB-15KKS1M)	SWITCH, UB-15KKS1M
5	60184	-	-	-	-	*	5	レンズ	LENS
6	60170-01	-	-	-	-	*	1	押しボタンマーク QR	PUSH BUTTON MARK, QR
7	60170-02	-	-	-	-	*	1	押しボタンマーク CD	PUSH BUTTON MARK, CD
8	60170-03	-	-	-	-	*	1	押しボタンマーク BC	PUSH BUTTON MARK, BC
9	60170-04	-	-	-	-	*	1	押しボタンマーク HS	PUSH BUTTON MARK, HS
10	60170-05	-	-	-	-	*	1	押しボタンマーク PC	PUSH BUTTON MARK, PC
11	60183	-	-	-	-	*	5	押しボタン	PUSH BUTTON
12	60181-02	-	-	-	-	*	1	スイッチケーブル	HARNESS
14	60467	-	-	-	-	*	1	コネクタピン	PIN CONTACT : LLF-01T-1.3E
15	60473	-	-	-	-	*	1	BTスイッチケーブル	HARNESS COMPLETE
17	60479	-	-	-	-	*	1	コネクタカバー15P	CONNECTOR CAP
18	60466	-	-	-	-	*	1	コネクタ15P	NYLON CONNECTOR
19	30750	-	-	-	-	*	1	結束バンド	CABLE TIE
20	60178	-	-	-	-	*	1	スイッチカバー板	SWITCH COVER PLATE
21	37288	-	-	-	-	*	2	スイッチカバー止	SCREW M4X0.7 L=5
22	60204	-	-	-	-	*	2	スイッチカバー板止	SCREW M4X0.7 L=6
23	31207	-	-	-	-	*	2	スイッチカバー板止ワッシャー	WASHER, PLAIN M 4
25	60543	-	-	-	-	*	7	コネクタピン	PIN CONTACT : LLM-01T-1.3E
26	E201271	-	-	-	-	*	2	抵抗	270Ω 1/4W
27	60181-01	-	-	-	-	*	2	電線	WIRE
28	60543	-	-	-	-	*	2	コネクタピン(BTスイッチ用)	PIN CONTACT : LLM-01T-1.3E
29	60572	-	-	-	-	*	2	収縮チューブ	HEAT SHRINKABLE TUBE
30	60573	-	-	-	-	*	2	収縮チューブ	HEAT SHRINKABLE TUBE
31	60618	-	-	-	-	*	2	保護チューブ	PROTECTIVE TUBE

空圧関係/Air pressure mechanism

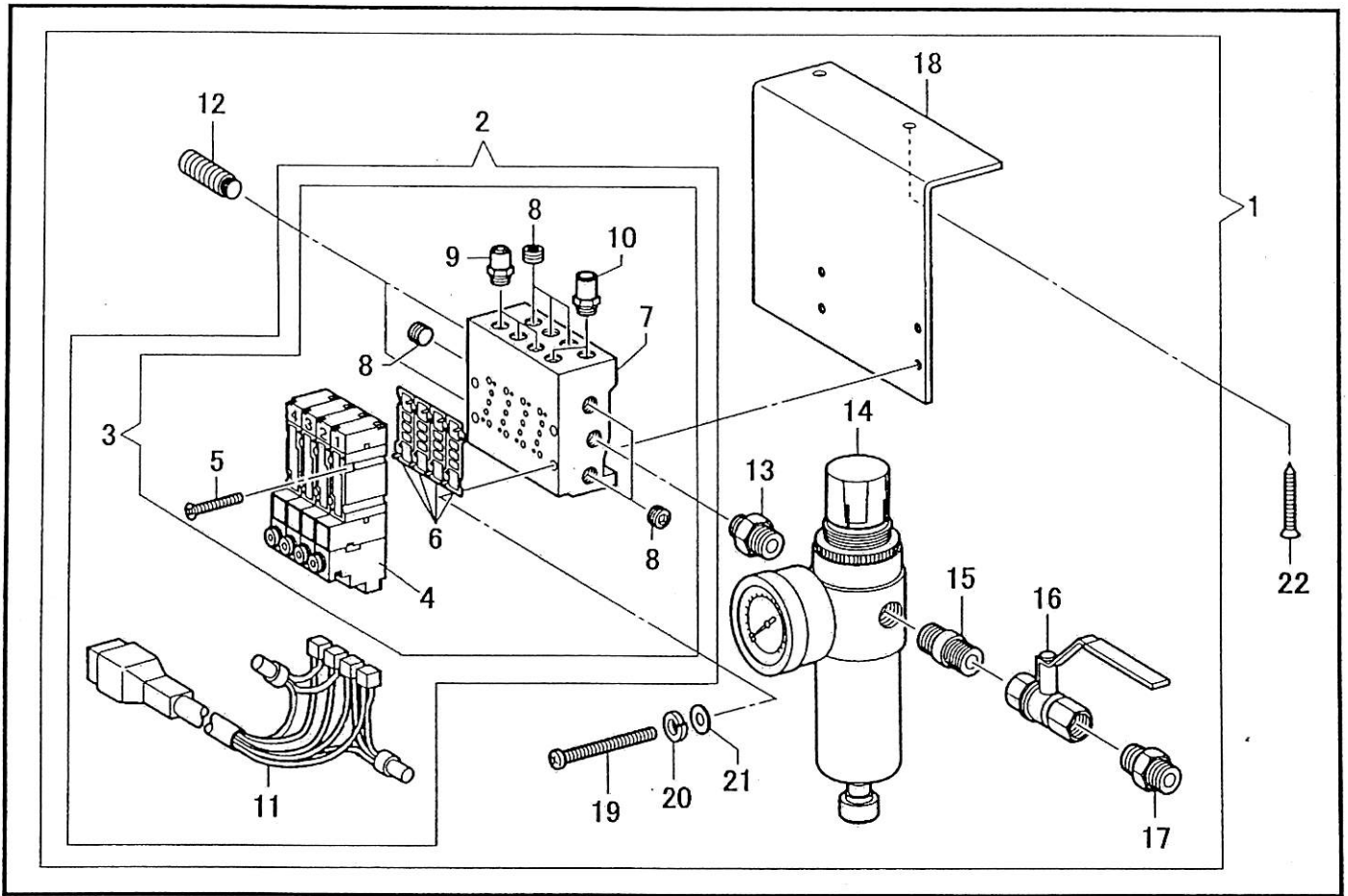

押えアクチュエータ関係(-FL)/Presser foot actuator mechanism (-FL)

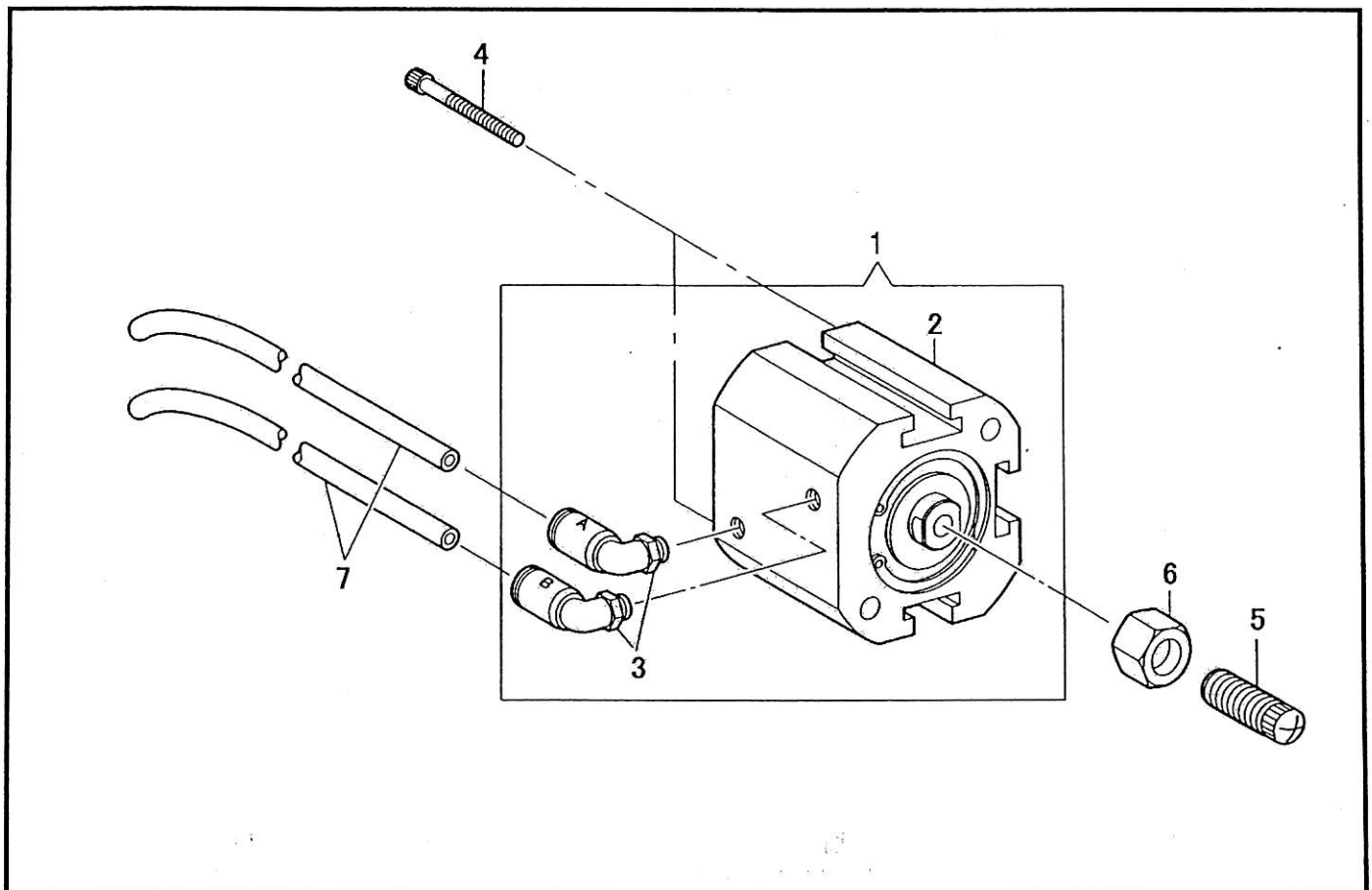

空圧関係/Air pressure mechanism

NO.	部品番号	-8BL -28BL	-8BLC -28BLC	-8BLC-BTFL- CD-DS/ -28BLC- BTFL-CD-DS	数量	品名	DESCRIPTION
	PARTS NO.				QTY		
1	60491	-	-	*	1	電磁弁セット(4連)	SOLENOID VALVE SET, 4
2	60387C	-	-	*	1	電磁弁(コネクタ付き)	SOLENOID VALVE ASSY, 4
3	60387	-	-	*	1	電磁弁(4連・24V)	AIR MANIFOLD ASSY, 4
4	60387-01	-	-	*	4	電磁弁	SOLENOID VALVE
5	60387-02	-	-	*	8	電磁弁止ねじ	SCREW, M2X0.4 L=20
6	60387-03	-	-	*	4	ガスケット(A05P-G)	GASKET
7	60387-04	-	-	*	1	エアマニホールド4(MFS4)	AIR MANIFOLD, 4
8	30720-03	-	-	*	6	プラグ(メクラ栓)	PLUG
9	60387-05	-	-	*	3	継手(A)	JOINT, A
10	60387-06	-	-	*	2	継手(B)	JOINT, B
11	60468	-	-	*	1	コネクタ4組	CONNECTOR ASSY, 4
12	60387-12	-	-	*	2	サイレンサー	AIR MUFFLER
13	BS09228	-	-	*	1	ニップル(A)	NIPPLE, 1/4X1/8
14	BS09318	-	-	*	1	レギュレーター	REGULATOR
15	60387-13	-	-	*	1	ニップル(B)	NIPPLE, B
16	60387-14	-	-	*	1	ボールバルブ	BALL VALVE
17	60387-15	-	-	*	1	ニップル(C)	NIPPLE, C
18	60387-16	-	-	*	1	電磁弁取付け板	SETTING PLATE, VALUE
19	60387-17	-	-	*	4	電磁弁止ねじ	SCREW, M4X0.7 L=38
20	31208	-	-	*	4	電磁弁止割ワッシャー	WASHER, SPRING 2-4
21	31207	-	-	*	4	電磁弁止平ワッシャー	WASHER, PLAIN M 4
22	10734-24	-	-	*	2	電磁弁取付け板止	WOOD SCREW, M4.5 L=20

押えアクチュエータ関係(-FL)/Presser foot actuator mechanism (-FL)

NO.	部品番号	-8BL -28BL	-8BLC -28BLC	-8BLC-BTFL- CD-DS/ -28BLC- BTFL-CD-DS	数量	品名	DESCRIPTION
	PARTS NO.				QTY		
1	60172	-	-	*	1	FLシリンダー(組)	CYLINDER ASSY
2	60172-01	-	-	*	1	FLシリンダー	CYLINDER
3	60172-02	-	-	*	2	継手	JOINT
4	60172-03	-	-	*	2	FLシリンダー止ねじ	BOLT, SOCKET M5X0.8 L=45
5	60174	-	-	*	1	FLシリンダー押しねじ	SCREW
6	28070	-	-	*	1	FLシリンダー押しねじナット	NUT, 3 M8
7	60169	-	-	*	2	FL用エアチューブ	AIR TUBE, 6X4X770L

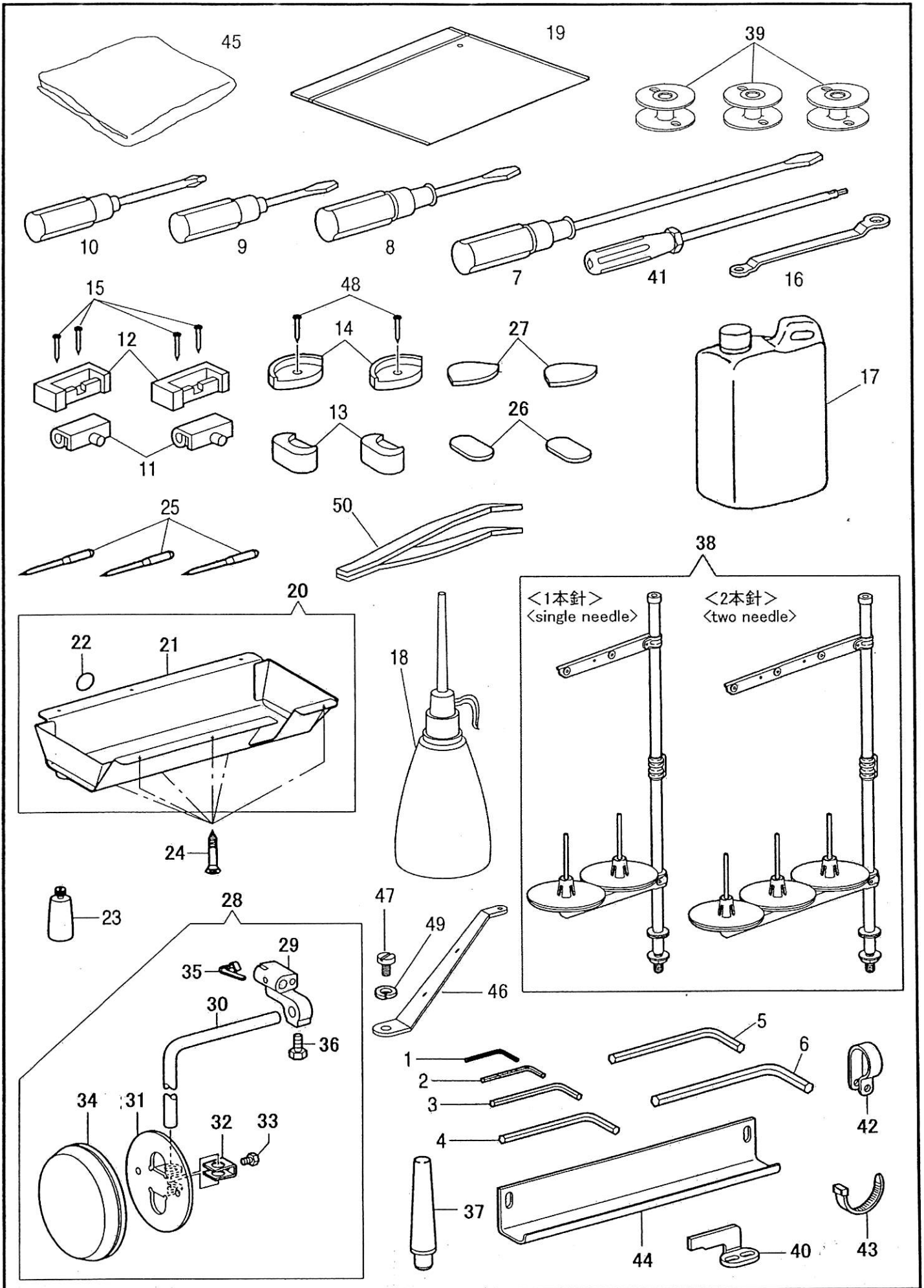



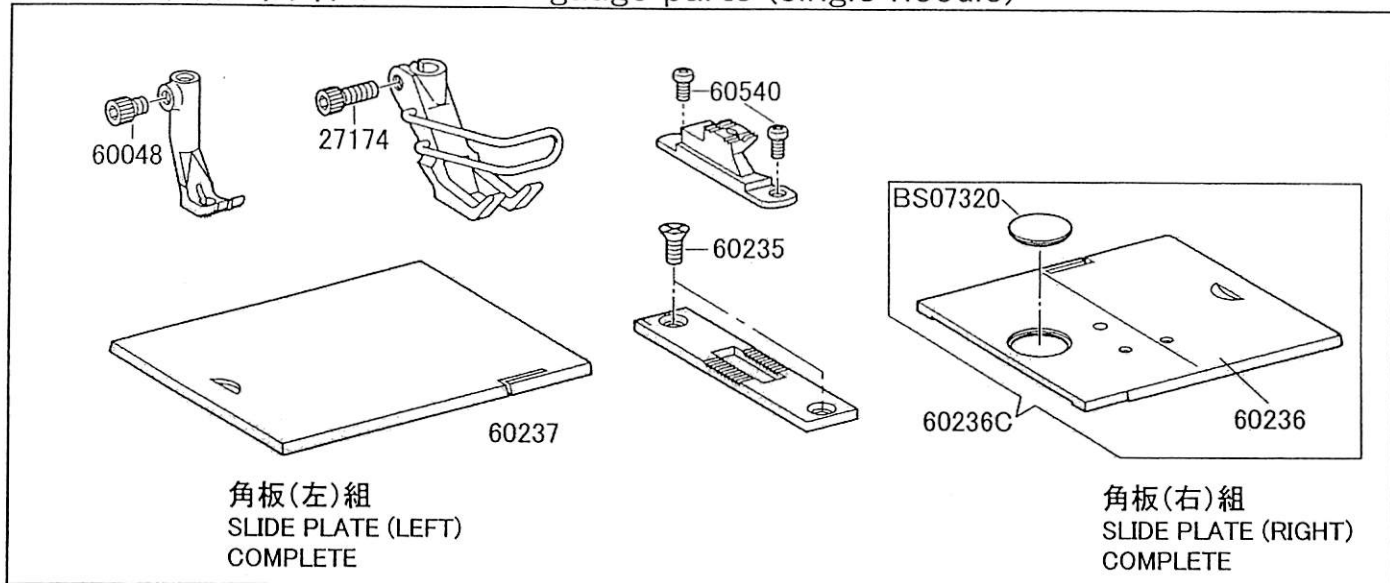

付属品関係/Accessories

NO.	部品番号	-8BL	-28BL	-8BLC	-28BLC	-8BLC- BTFL-CD-DS	-28BLC- BTFL-CD-DS	数量	品名	DESCRIPTION
	PARTS NO.							QTY		
1	1872	*	*	*	*	*	*	1	六角レンチ(1.5MM)	HEXAGONAL WRENCH, 1.5
2	19456	*	*	*	*	*	*	1	六角レンチ(2MM)	HEXAGONAL WRENCH, 2
3	19457	*	*	*	*	*	*	1	六角レンチ(2.5MM)	HEXAGONAL WRENCH, 2.5
4	19458-A	*	*	*	*	*	*	1	六角レンチ(3MM)	HEXAGONAL WRENCH, 3
5	19459	*	*	*	*	*	*	1	六角レンチ(4MM)	HEXAGONAL WRENCH, 4
6	19460	*	*	*	*	*	*	1	六角レンチ(5MM)	HEXAGONAL WRENCH, 5
7	8118	*	*	*	*	*	*	1	ドライバー(大)	SCREW DRIVER, L
8	8120	*	*	*	*	*	*	1	ドライバー(中)	SCREW DRIVER, M
9	8121	*	*	*	*	*	*	1	ドライバー(小)	SCREW DRIVER, S
10	19473	*	*	*	*	*	*	1	十字ドライバー	SCREW DRIVER, PLUS
11	11885	*	*	*	*	*	*	2	ヒンジ	HINGE
12	B143910	*	*	*	*	*	*	2	ヒンジ受けゴム	RUBBER CUSHION
13	BS53188	*	*	*	*	*	*	2	コーナー受け(B)	CORNER SUPPORT
14	B148890	*	*	*	*	*	*	2	コーナー受け(A)	HEAD CUSHION
15	6055	*	*	*	*	*	*	4	ヒンジ受け止釘	NAIL
16	19462	*	*	*	*	*	*	1	メガネレンチ	DOUBLE WRENCH
17	11193	*	*	*	*	*	*	1	オイルタンク	OIL TANK
18	8125	*	*	*	*	*	*	1	油差し	OILER
19	8132-A	*	*	*	*	*	*	1	部品袋	ACCESSORY BAG
20	60386C	*	*	*	*	*	*	1	油受け(組)	OIL PAN ASSY
21	60386	*	*	*	*	*	*	1	油受け	OIL PAN
22	PL-09	*	*	*	*	*	*	1	アースラベル	LABEL, GROUNDING
23	15082	*	*	*	*	*	*	1	油びん	POLY OILER
24	15081	*	*	*	*	*	*	6	油受け取付けねじ	WOOD SCREW
25	N0122	*	-	*	-	*	-	3	針 DPx17 #22	NEEDLE DPX17 (#22)
25	N0122	-	*	-	*	-	*	4	針 DPx17 #22	NEEDLE DPX17 (#22)
26	BS53190	*	*	*	*	*	*	2	頭部敷ゴム間座	SPACER, C-SUPPORT
27	BS53189	*	*	*	*	*	*	2	コーナー受けゴム間座	SPACER, H-CUSHION
28	60478C	*	*	*	*	-	-	1	膝当て(組)	KNEE LIFTER ASSY
29	60478	*	*	*	*	-	-	1	膝上げ継手	BRACKET, KNEE LIFTER
30	B104619	*	*	*	*	-	-	1	膝上げ立て軸	KNEE LIFTER BAR
31	BS34756	*	*	*	*	-	-	1	膝当て	KNEE LIFTER PLATE
32	B114967	*	*	*	*	-	-	1	膝当てストッパー	STOPPER, ;K-LIFTER PLATE
33	B110087	*	*	*	*	-	-	1	膝当て止	BOLT, SM5.95X28 L=8
34	BS31885	*	*	*	*	-	-	1	膝当てカバー	COVER, ;K-LIFTER PLATE
35	BS25783	*	*	*	*	-	-	1	膝上げ継手ばね	SPRING
36	B017081	*	*	*	*	-	-	1	膝上げ継手固定ねじ	BOLT, M8X1.25 L=16
37	B100477	*	*	*	*	*	*	1	頭部受け棒	HEAD REST
38	35254	*	-	*	-	*	-	1	糸立セット	THREAD STAND ASSY
38	10947	-	*	-	*	-	*	1	糸立セット	THREAD STAND ASSY
39	60536	*	-	*	-	*	-	3	ボビン	BOBBIN
39	60536	-	*	-	*	-	*	4	ボビン	BOBBIN
40	60302	-	-	*	-	*	-	1	固定メス	FIXED KNIFE
40	60302	-	-	-	*	-	*	2	固定メス	FIXED KNIFE
41	60699	-	*	-	*	-	*	1	六角棒ねじ回し	SCREW DRIVER, HEXAGONAL 2.5
42	30625	-	-	*	*	*	*	1	検出器ケーブルクランプ	SYNCRONIZER CABLE CLAMP, 5N
43	60374	-	-	*	*	*	*	1	結束バンド	CABLE TIE
44	60012	-	-	-	-	*	*	1	コードカバー	CORD COVER
45	8124	*	*	*	*	*	*	1	マシンカバー	MACHINE COVER
46	38264	-	-	*	-	*	-	1	アーム糸掛け	THREAD GUIDE
46	38264	-	-	-	*	-	*	2	アーム糸掛け	THREAD GUIDE
47	30601	-	-	*	*	*	*	1	アーム糸掛け止めねじ	SCREW M5X0.8 L=10
48	6055	*	*	*	*	*	*	2	コーナー受け(A)止釘	NAIL
49	90625	-	-	*	-	*	-	1	スプリングワッシャー	SPRING WASHER
49	90625	-	-	-	*	-	*	2	スプリングワッシャー	SPRING WASHER
50	11196	-	*	-	*	-	*	1	ピンセット	TWEEZERS

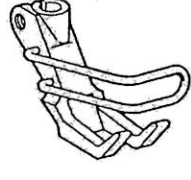
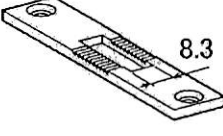
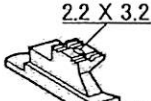
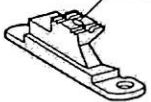
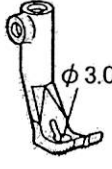
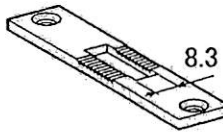
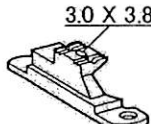
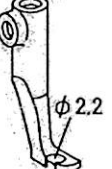
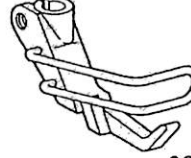
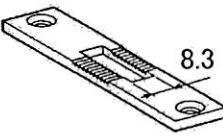
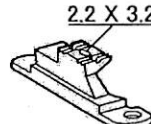
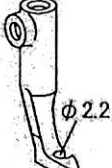

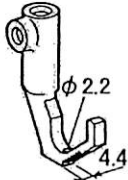
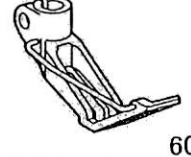
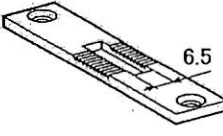

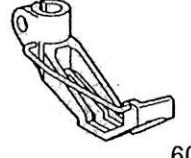

ゲージ表(1本針) / Table of gauge parts (single needle)

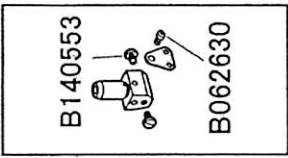

	中押え INNER PRESSER FOOT	外押え(組) OUTER PRESSER FOOT	針板 NEEDLE PLATE	送り歯 FEED DOG
標準 STANDARD	 $\phi 2.2$ 60049	 60051	 8.3 60234	 2.2 X 3.2 60309
* 長穴(送り歯) LONG HOLE (FEED DOG)				 2.2 X 4.0 60423
* 太糸用 FOR THICK THREAD	 $\phi 3.0$ 60402	60051	 8.3 60470	 3.0 X 3.8 60421
* 片押え・右 RIGHT SIDE FOOT	 $\phi 2.2$ 60400	 60410	 8.3 60234	 2.2 X 3.2 60309
* 片押え・左 LEFT SIDE FOOT	 $\phi 2.2$ 60401	 60411		
* ウレタン用(A1) FOR URETHANE (A1)	 $\phi 2.2$ 4.4 60404	 60415	 6.5 60471	 2.2 X 3.2 6.2 60422
* ウレタン用(A2) FOR URETHANE (A2)		 60416		

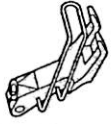
\* 特別注文品 / OPTION AT EXTRA COST

ゲージ表(2本針) / Table of gauge parts (two needle)

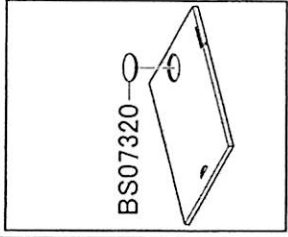
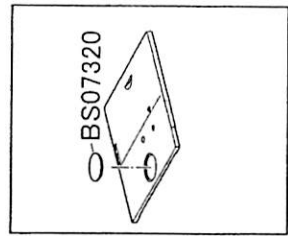
針巾	セットNo.	針抱き(組)	中押え	外押え(組)	列	針板	送り歯	針棒 糸案内	角板(左)組	角板(右)組
	GAUGE SIZE	SET NO.	INNER PRESSER FOOT	OUTER PRESSER FOOT	ROW	NEEDLE PLATE	FEED DOG		SLIDE PLATE (LEFT) COMPLETE	SLIDE PLATE (RIGHT) COMPLETE
		 B140553 B062630						 BS07320	 BS07320	
	3mm	60690C	60670	60680	1	60640	60650	60624	60636C	60236C
	4mm	60691C	60671		1	60641	60651			
	6mm	60692C	60672	60681	2	60642	60652	60625	60636C	60236C
	8mm	60693C	60673	60682	2	60643	60653			
	10mm	60694C	60674	60683	2	60644	60654	60625	60636C	60236C
	12mm	60695C	60675	60684	2	60645	60655			
	16mm	60689C	60676	60685	3	60646	60656		60637C	

\* 3mm

\* 4mm

\* 16mm

\* 特別注文品 / OPTION AT EXTRA COST



吊り定規 (オプション) / Hanging ruler (option)

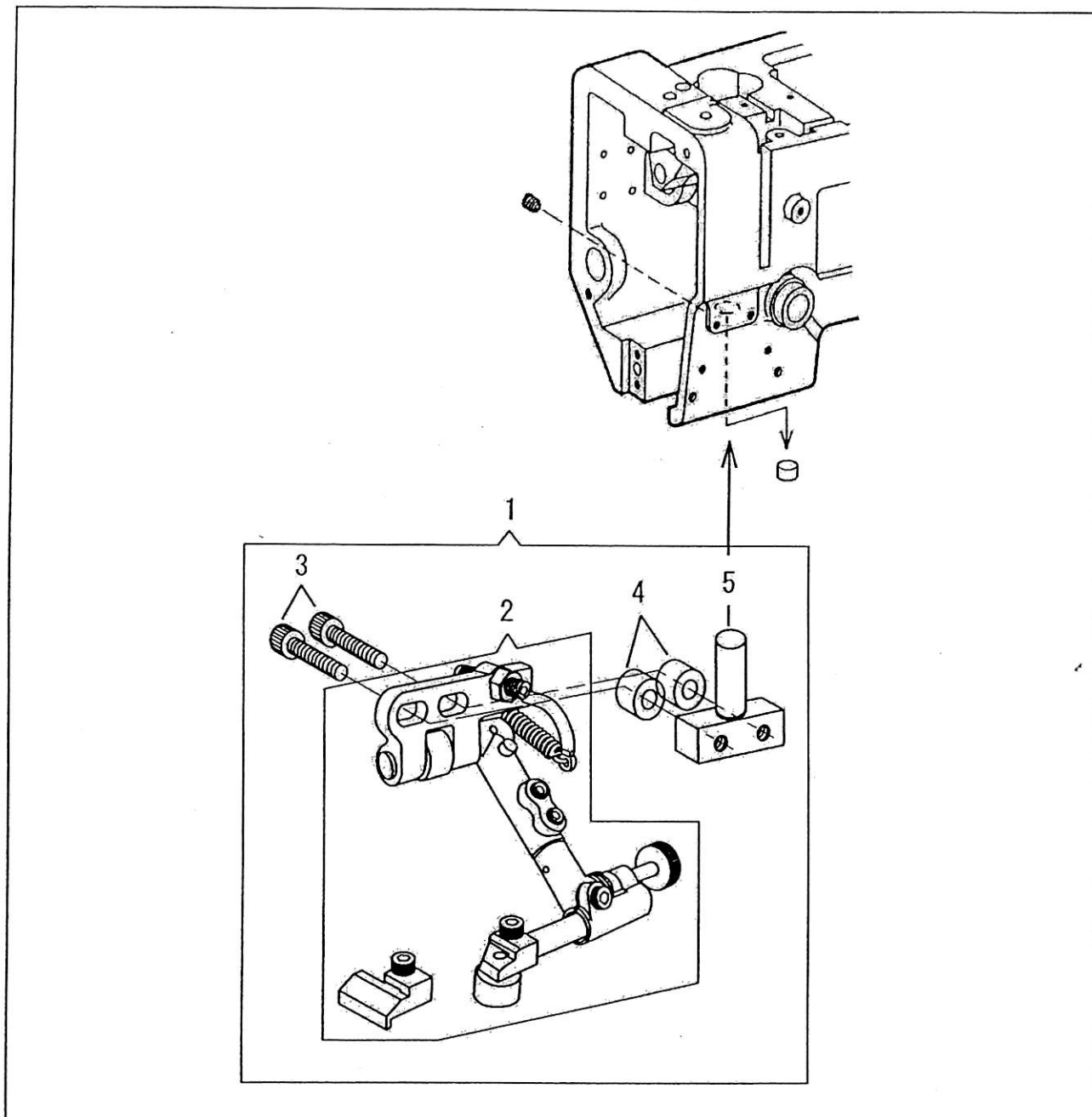

NO.	部品番号	数量	品名	DESCRIPTION
	PARTS NO.	QTY		
1	60546C	1	吊り定規 (組)	HANGING RULER, COMPLETE
2	60546	1	吊り定規	HANGING RULER
3	36317	2	ねじ	SCREW M6X1 L=22
4	37301	2	スペーサー	SPACER
5	60546-01	1	吊り定規土台	HANGING RULER BRACKET

## SEIKO SEWING MACHINE CO., LTD.

2-13-6 Sakaecho, Funabashi-shi Chiba Prefecture,  
273-0018, Japan

TEL: 81-47-420-3561 (Overseas dept.)

FAX: 81-47-420-3560

E-mail: [export@seiko-sewing.co.jp](mailto:export@seiko-sewing.co.jp)

<http://www.seiko-sewing.co.jp/>

## セイコーミシン株式会社

〒273-0018 千葉県船橋市栄町2-13-6

TEL: 047-420-3561, IP電話: 050-3535-3491

FAX: 047-420-3560

E-mail: [eigyo@seiko-sewing.co.jp](mailto:eigyo@seiko-sewing.co.jp)

(国内営業)

Parts No. PB99410 (0411)

Rev.5