

下送り関係 (8BV-2)

BOTTOM FEED MECHANISM (8BV-2)

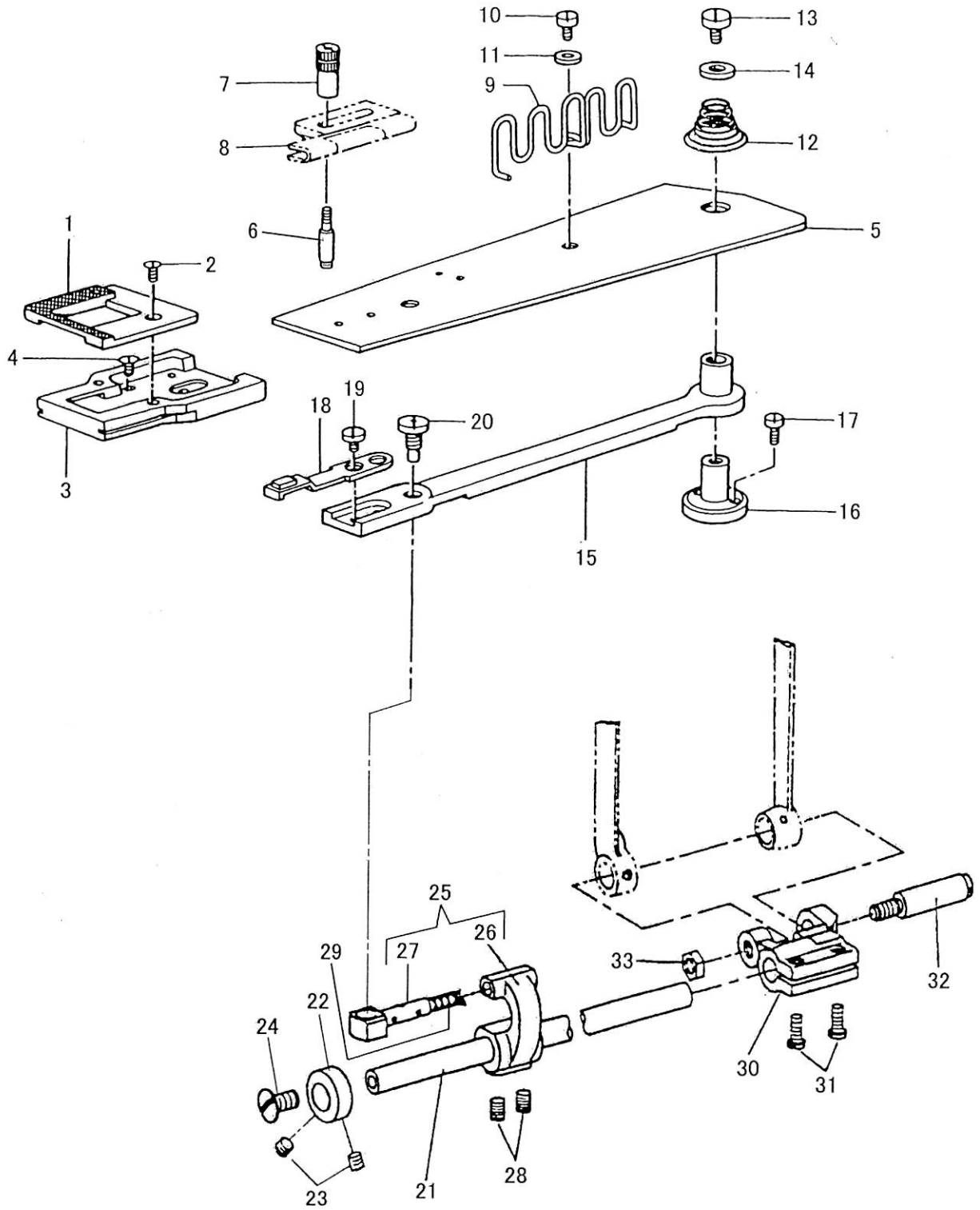

下送り関係 (8BV-2)

BOTTOM FEED MECHANISM (8BV-2)

No.	部品番号 PARTS NO.	8BV-2	個数 QTY	品名	DESCRIPTION
1	17813	*	1	針板	NEEDLE PLATE
2	6031-01	*	2	針板止	SCREW 11/64X40 L=9
3	17814	*	1	針板受台	N/P. SUPPORTING PLATE
4	17815	*	4	針板受台止	SCREW 9/64X40 L=6.5
5	17816C	*	1	送り板(ねじ付) 組	BINDING PLATE COMP.
6	17079	*	2	バインダー止ねじ	BINDER SCREW
7	17080	*	2	バインダー止ナット	BINDER NUT
8	13271	*	1	バインダー 2A-14-6 (オプション)	BINDER (2A-14-6) OPTION
9	13256	*	1	テープ案内	TAPE GUIDE
10	17104	*	1	テープ案内止	SCREW 11/64X40 L=6
11	11142	*	1	テープ案内止ワッシャー	WASHER
12	17817	*	1	送り腕スプリング	SPRING
13	17064	*	1	送り腕台押しねじ	SCREW 9/64X40 L=7
14	17070	*	1	送り腕台ワッシャー	WASHER
15	17818	*	1	送り腕	FEED ROCK SHAFT BASE
16	17819	*	1	送り腕台	FEED ARM BASE
17	17104	*	2	送り腕台止	SCREW 11/64X40 L=6
18	17820	*	1	送り歯	FEED DOG
19	17076	*	2	送り歯止	SCREW 1/8X44 L=4
20	17821	*	1	送り腕ピンねじ	HINGE SCREW
21	17822	*	1	送り軸	FEED DRIVING ROCK SHAFT
22	17823	*	1	送り軸カラー	FEED DRIVING ROCK SHAFT COLLAR
23	12421	*	2	送り軸カラー止	SCREW 11/64X32 L=4
24	17064	*	1	送り軸押しねじ	SCREW 9/64X40 L=7
25	17824C	*	1	送り揺動台(ピン付)	FEED FORK W/PIN
26	17824	*	1	送り揺動台	FEED FORK
27	17643	*	1	送り揺動台ピン	FEED FORK PIN
28	8097	*	2	送り揺動台止	SCREW 15/64X28 L=5
29	10728	*	1	送り揺動台ピン油芯 6X6	OIL WICK 6X6 L=20
30	17825	*	1	送り竿だるま	FEED ROCK SHAFT CRANK
31	17638	*	2	送り竿だるま締ねじ	PINCH SCREW M6X1 L=12
32	17826	*	1	送り竿だるまピン	FEED SHAFT CRANK PIN
33	17827	*	1	送り竿だるまピンナット	NUT 17/64X32

下送り関係 (8B-2)

BOTTOM FEED MECHANISM (8B-2)

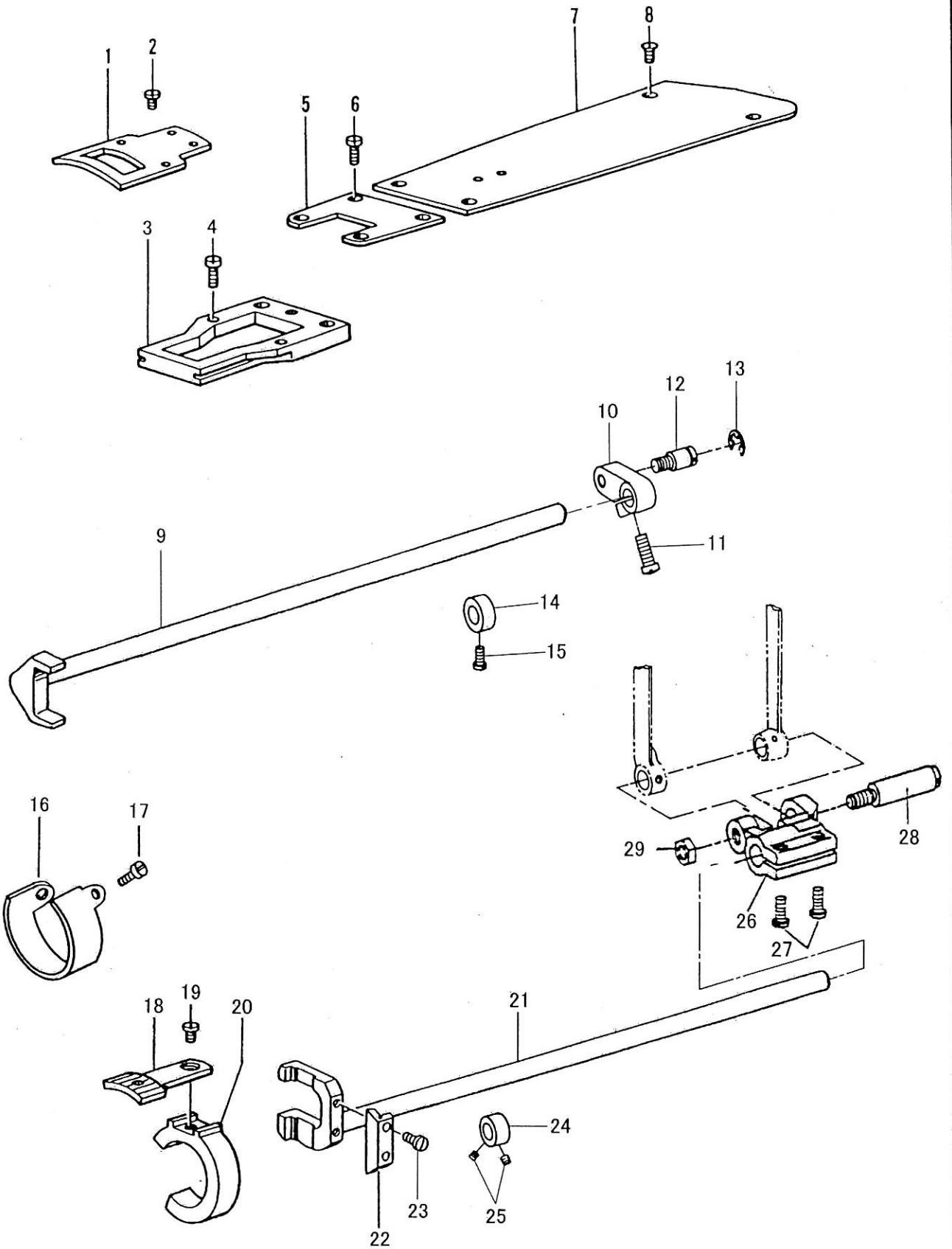

下送り関係 (8B-2)

BOTTOM FEED MECHANISM (8B-2)

No.	部品番号 PARTS NO.	8B-2 *	個数 QTY	品名	DESCRIPTION
1	17828	*	1	針板	NEEDLE PLATE
2	6344	*	2	針板止	SCREW 3/32X56 L=5
3	17829	*	1	針板受台(6mm)	NEEDLE PLATE SUPPORT
4	17223	*	2	針板受台止	SCREW 9/64X40 L=11
5	17224	*	1	針板補助板	NEEDLE PLATE ASSIST
6	8100	*	4	針板補助板止	SCREW 9/64X40 L=6.5
7	17202	*	1	ベッド上板	BED PLATE
8	8016	*	4	ベッド上板止	SCREW 9/64X40 L=5.5
9	17830	*	1	送り上下軸	FEED LIFTING SHAFT
10	17831	*	1	送り上下だるま	CRANK
11	1365	*	1	送り上下だるま締めねじ	PINCH SCREW 15/64X28 L=16
12	17832	*	1	送り上下ロッド段ねじ	HINGE SCREW 9/32X28 L=10
13	17833	*	1	送り上下ロッド段ねじ止輪	"E" RING
14	17834	*	1	送り上下軸カラー	FEED LIFTING SHAFT COLLAR
15	15055	*	1	送り上下軸カラー止	SCREW 11/64X32 L=9
16	17835	*	1	シリンダーカバー	BED END COVER
17	17836	*	2	シリンダーカバー止	SCREW 9/64X40 L=4
18	17837	*	1	送り歯	FEED DOG (6 m/m)
19	17232	*	1	送り歯止	SCREW 9/64X40 L=7
20	17218	*	1	送り土台	FEED BASE
21	17838	*	1	送り軸	FEED ROCK SHAFT
22	17226	*	1	送り土台すべり板	FEED BASE GIB
23	17839	*	2	送り土台すべり板止	SCREW 1/8X44 L=6.5
24	17840	*	1	送り軸カラー	FEED ROCK SHAFT COLLAR
25	12421	*	2	送り軸カラー止	SCREW 11/64X32 L=4
26	17841	*	1	送り竿だるま	FEED CRANK
27	17638	*	2	送り竿だるま締めねじ	PINCH SCREW 6X1 L=12
28	17842	*	1	送り竿だるまピン	CRANK PIN
29	17843	*	1	送り竿だるまピンナット	NUT 17/64X32

返し機構
FEED REVERSING MECHANISM

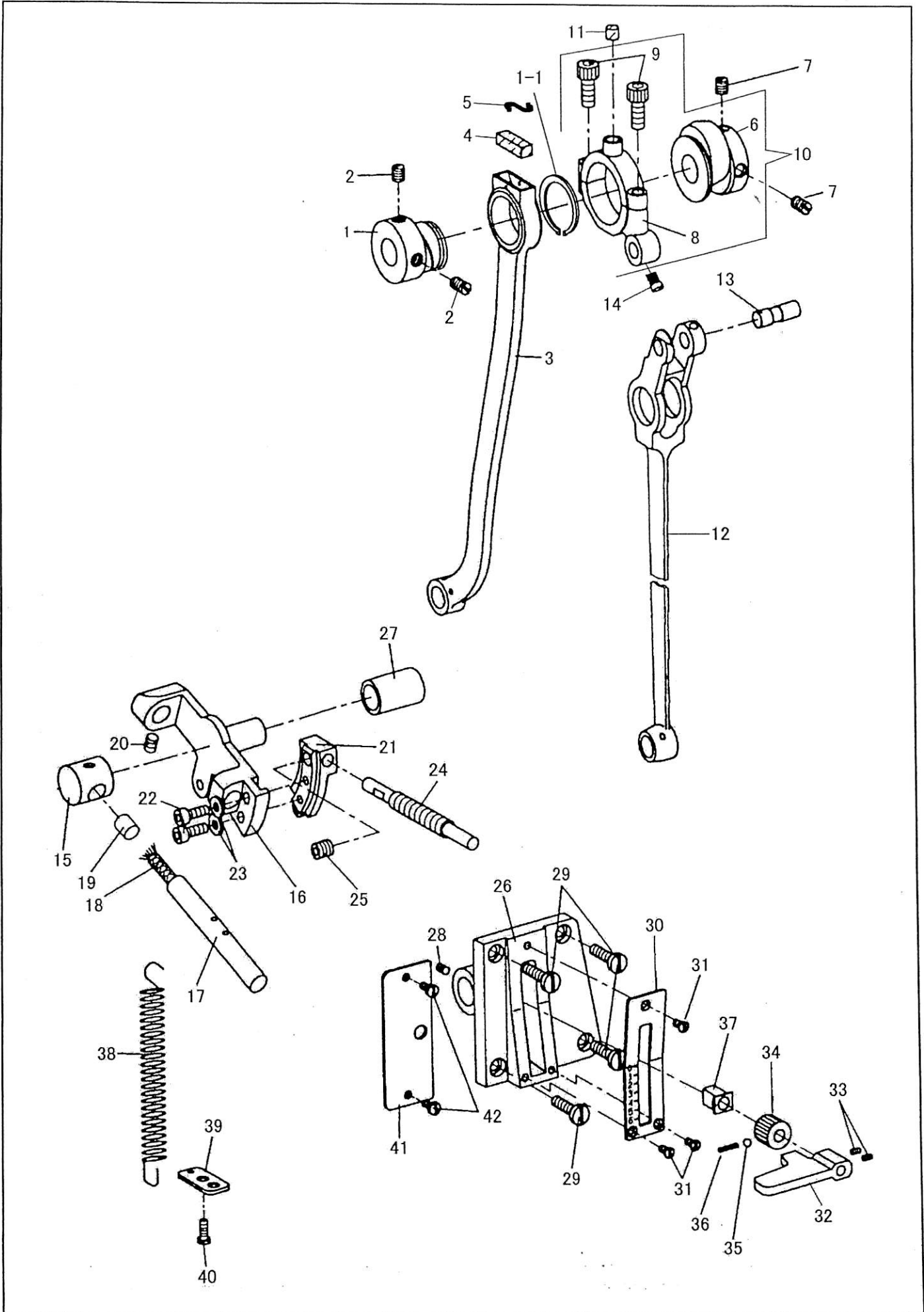

返し機構

FEED REVERSING MECHANISM

No.	部品番号 PARTS NO.	8B-2	8BV-2	個数 QTY	品名	DESCRIPTION
1	17844	*	-	1	上下カム	FEED CAM,UD
1-1	17862	*	-	1	止め輪	C-RING
2	17845	*	-	2	上下カム止	SCREW 1/4X40 L=7
3	17846	*	-	1	送り上下ロッド	FEED ROD,UD
4	17026	*	-	1	送り上下ロッドフェルト	OIL FELT
5	10723	*	-	1	フェルト押え	OIL FELT STOPPER
6	17616	*	*	1	送りカム	FEED ECCENTRIC CAM
7	17019	*	*	2	送りカム止	SCREW 1/4X40 L=7.5
8	17847	*	*	1	送り連結ロッド	FEED C/ROD COMPLETE
9	30066	*	*	2	送り連結ロッド締めじ	PINCH SCREW M5X0.8 L=12
10	17617C	*	*	1	送り連結ロッド(組)	FEED C/ROD COMPLETE
11	17629	*	*	1	送り連結ロッドフェルト	OILING FELT
12	17711	*	-	1	送りロッド	FEED ROD
12	17848	-	*	1	送りロッド	FEED ROD
13	17621	*	*	1	送り連結ピン	FEED CONNECTION PIN
14	17849	*	*	1	送り連結ピン止	SCREW M4X0.7 L=5
15	17619	*	*	1	送り案内駒	FEED GUIDE BLOCK
16	17850	*	*	1	送り調節	FEED REGULATING
17	17851	*	*	1	送り案内ピン	FEED GUIDE PIN
18	10726	*	*	1	送り案内ピン油芯	OIL WICK 6X6 L=30
19	15038	*	*	1	送り案内ピンゴム栓	RUBBER
20	17852	*	*	1	送り案内ピン止	SCREW 15/64X28 L=6
21	17853	*	*	1	レバーピンねじ受け金	SET PLATE
22	31092	*	*	2	レバーピンねじ受け金止	SCREW M4X0.7 L=12
23	30078	*	*	2	ピンねじ受け金止ワッシャー	WASHER
24	17854	*	*	1	レバーピンねじ	LEVER PIN SCREW
25	17855	*	*	1	レバーピンねじ止	SCREW 15/64X32 L=8
26	17856	*	*	1	送り調節台	FEED REGULATING BASE
27	17624	*	*	1	送り調節台メタル	F/R BASE BUSHING
28	8097	*	*	1	送り調節台メタル止	SET SCREW 15/64X28 L=5
29	12361	*	*	4	送り調節台止	SCREW 13/64X32 L=14
30	17626	*	*	1	送り目盛板 6.0	S/T INDICATING PLATE
31	17093-02	*	*	3	送り目盛板止	SCREW 9/64X40 L=6.5
32	18027	*	*	1	送り調節レバー	REVERSE FEED LEVER
33	18028	*	*	2	レバーピンねじ止(小)	SCREW M5X0.8 L=5
34	13416	*	*	1	送り調節ローレット	KNURLING TOOL
35	8158	*	*	1	レバーボール(3.17)	FEED REGULATOR BALL
36	8157	*	*	1	レバースプリング	FEED REGULATOR SPRING
37	17857	*	*	1	送り調節パイプ	FEED ADJUSTING PIPE
38	18026	*	*	1	レバースプリング	FEED REGULATOR SPRING
39	20322	*	*	1	掛金スプリング受	SPRING HOOK PLATE
40	37136	*	*	1	掛金スプリング受止	SCREW M5X0.8 L=10
41	17603	*	*	1	アーム横カバー	ARM SIDE COVER
42	8100	*	*	2	アーム横カバー止	SCREW 9/64X40 L=6.5

糸掛け、糸調子関係
THREAD GUIDE, THREAD TENSION

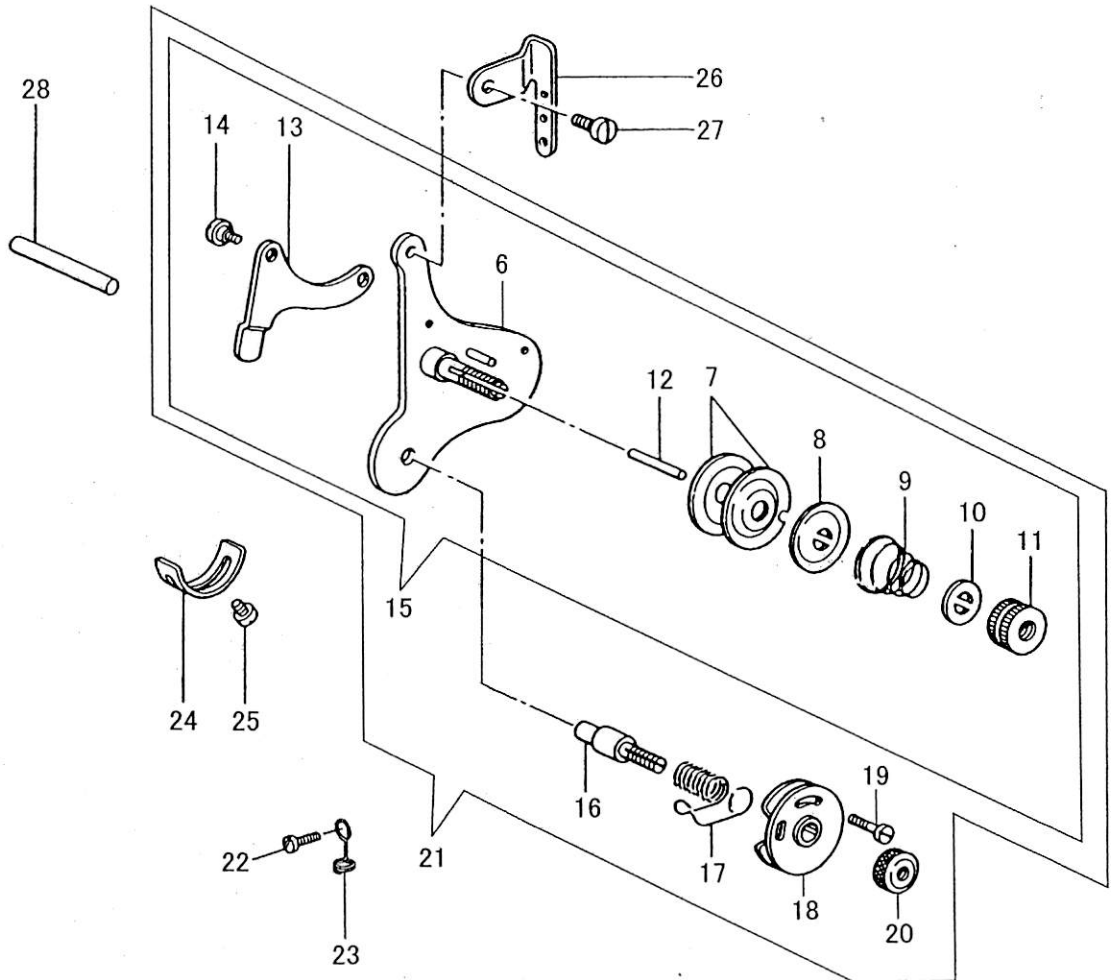
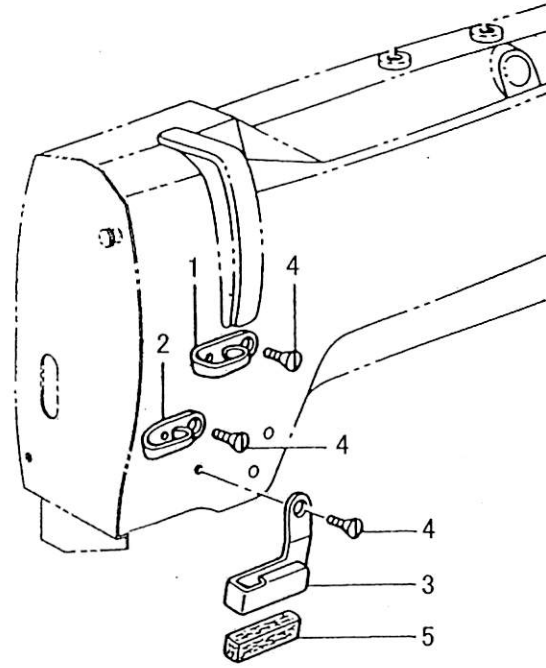

糸掛け、糸調子関係

THREAD GUIDE, THREAD TENSION

No.	部品番号 PARTS NO.	8B-2	8BV-2	個数 QTY	品名	DESCRIPTION
1	10682	*	*	1	面糸掛(上)	THREAD GUIDE (UPPER)
2	17859	*	*	1	面糸掛(中)	THREAD GUIDE (MIDDLE)
3	10759-A	*	*	1	面糸掛(下)	THREAD GUIDE (LOWER)
4	19510	*	*	3	面糸掛止	SCREW 9/64X40 L=6.5
5	10760	*	*	1	面糸掛フェルト	FELT FOR THREAD GUIDE
6	19421	*	*	1	調子板	TENSION BRACKET
7	19531	*	*	2	調子皿	TENSION DISC
8	19532	*	*	1	丸一皿	TENSION RELEASING WASHER
9	19533	*	*	1	渦巻スプリング 1.4	TENSION DISC SPRING 1.4
10	28206	*	*	1	ローレットストッパー	T/THUMB NUT STOPPER
11	19513	*	*	1	ローレットナット	TENSION THUMB NUT
12	10793	*	*	1	糸ゆるめ段ピン	RELEASE PLUNGER
13	10678	*	*	1	糸ゆるめ板	TENSION RELEASE LEVER
14	19422	*	*	2	糸ゆるめ板段ねじ	HINGE SCREW 9/64X40 L=2.5
15	19421C-A	*	*	1	調子板 組 1.4	T/BRACKET (1.4) COMP.
16	19512	*	*	1	糸調子棒(短)	TENSION SCREW STUD
17	10689	*	*	1	糸引スプリング	THREAD TAKE-UP SPRING
18	10694	*	*	1	二重皿	THREAD CONTROLLER DISC
19	B118319	*	*	1	二重皿止	SCREW 3/32X56 L=6.0
20	19534	*	*	1	ローレットナット	TENSION THUMB NUT
21	19474C	*	*	1	調子板 大組 1.4	TENSION BRACKET(1.4) COMP.
22	15007	*	*	1	糸調子棒(短)止	SCRELW 9/64X40 L=10
23	4221	*	*	1	油芯押え	OIL WICK RETAINER
24	10690	*	*	1	スプリング受	TAKE-UP SPRING STOP
25	8100	*	*	1	スプリング受止	SCREW 9/64X40 L=6.5
26	15062	*	*	1	太糸掛	THREAD RETAINER
27	15055	*	*	1	調子板止	SCREW 11/64X32 L=9
28	10720	*	*	1	糸ゆるめピン(長)	RELEASE LEVER ROD

ベルトガード、フィンガーガード
BELT GUARD, FINGER GUARD

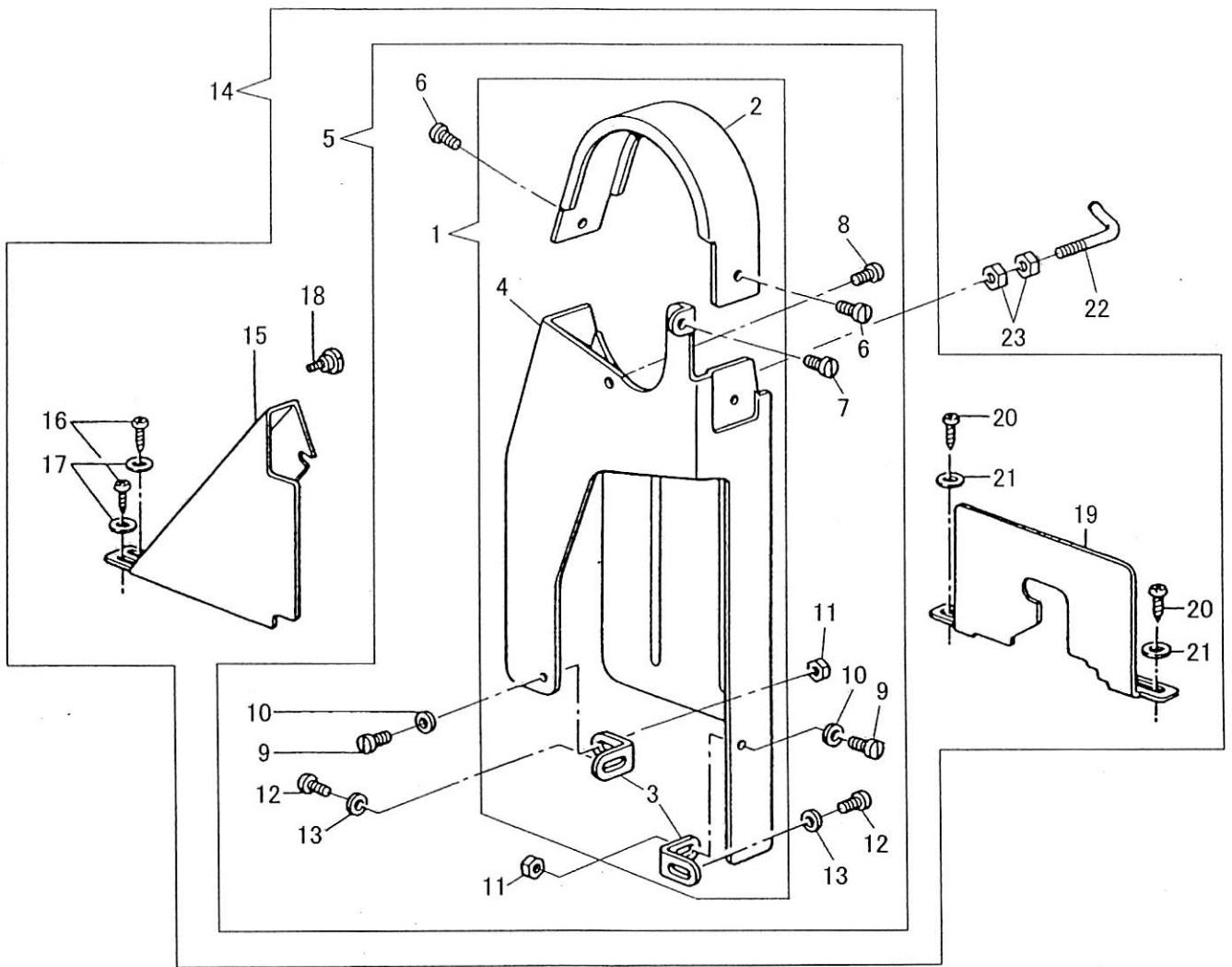

Synchronizer support rod

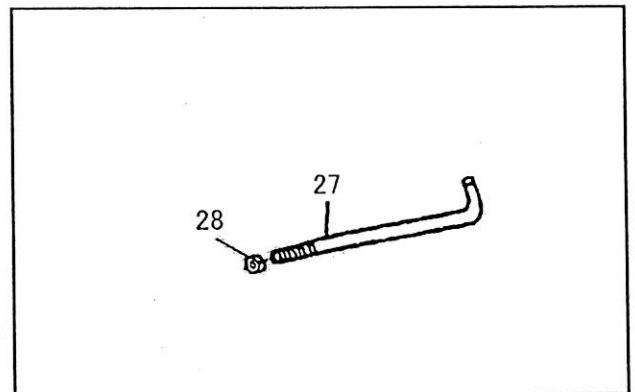

ベルトガード、フィンガーガード
BELT GUARD, FINGER GUARD

No.	部品番号 PARTS NO.	8B-2	8BV-2	個数 QTY	品名	DESCRIPTION
1	13425C	*	*	1	ベルトガード 3点組	BELT GUARD COMPLETE
2	13426	*	*	1	ベルトガード上カバー	BELT GUARD COVER
3	13427	*	*	2	ベルトガード止金具	BELT GUARD SET PLATE
4	13425	*	*	1	ベルトガード本体	BELT GUARD BODY
5	17862C	*	*	1	ベルトガード 組	BELT GUARD COMPLETE
6	6339	*	*	2	ベルトガード上カバー止	SCREW 1/8X44 L=4.0
7	18480	*	*	1	ベルトガード本体止(A)	SCREW 11/64X40 L=8.0
8	13479	*	*	1	ベルトガード本体止(B)	SCREW 9/64X40 L=6.5
9	14024	*	*	2	ベルトガード止金具止ねじ	SCREW 3/16X32 L=9.5
10	16287	*	*	2	止金具止ねじワッシャー	WASHER
11	50103	*	*	2	止金具止ねじナット	NUT
12	10561	*	*	2	ベルトガード止(下)	SCREW 11/64X32 L=6.5
13	11142	*	*	2	ベルトガード止(下)ワッシャー	WASHER
14	17865C	*	*	1	ベルトガード 組	BELT GUARD COMP.
15	13428	*	*	1	ベルトガード補助ガード	B/GUARD SUPPORT GUARD
16	15081	*	*	2	補助ガード木ねじ	WOOD SCREW
17	11142	*	*	2	補助ガード木ねじワッシャー	WASHER
18	11830	*	*	1	補助ガード止ねじ	THUMB SCREW 9/64X40 L=5.8
19	13429	*	*	1	ベルトガード補助板	SUPPORT PLATE
20	15081	*	*	2	補助板木ねじ	WOOD SCREW
21	11142	*	*	2	補助板木ねじワッシャー	WASHER
22	30168	*	*	1	検出器支え棒	SYNCHRONIZER SUPPORT
23	50409	*	*	2	検出器支え棒ナット	NUT
24	19470	*	*	1	フィンガーガード	FINGER GUARD
25	10749	*	*	1	外押え止(ガード付用)	FINGER GUARD SET SCREW
26	10677	*	*	1	外押え止ワッシャー	WASHER
27	17372	*	*	1	検出器支え棒(ガード無し用)	SYNCHRONIZER SUPPORT
28	50409	*	*	1	検出器支え棒ナット	NUT

付属品
ACCESSORIES

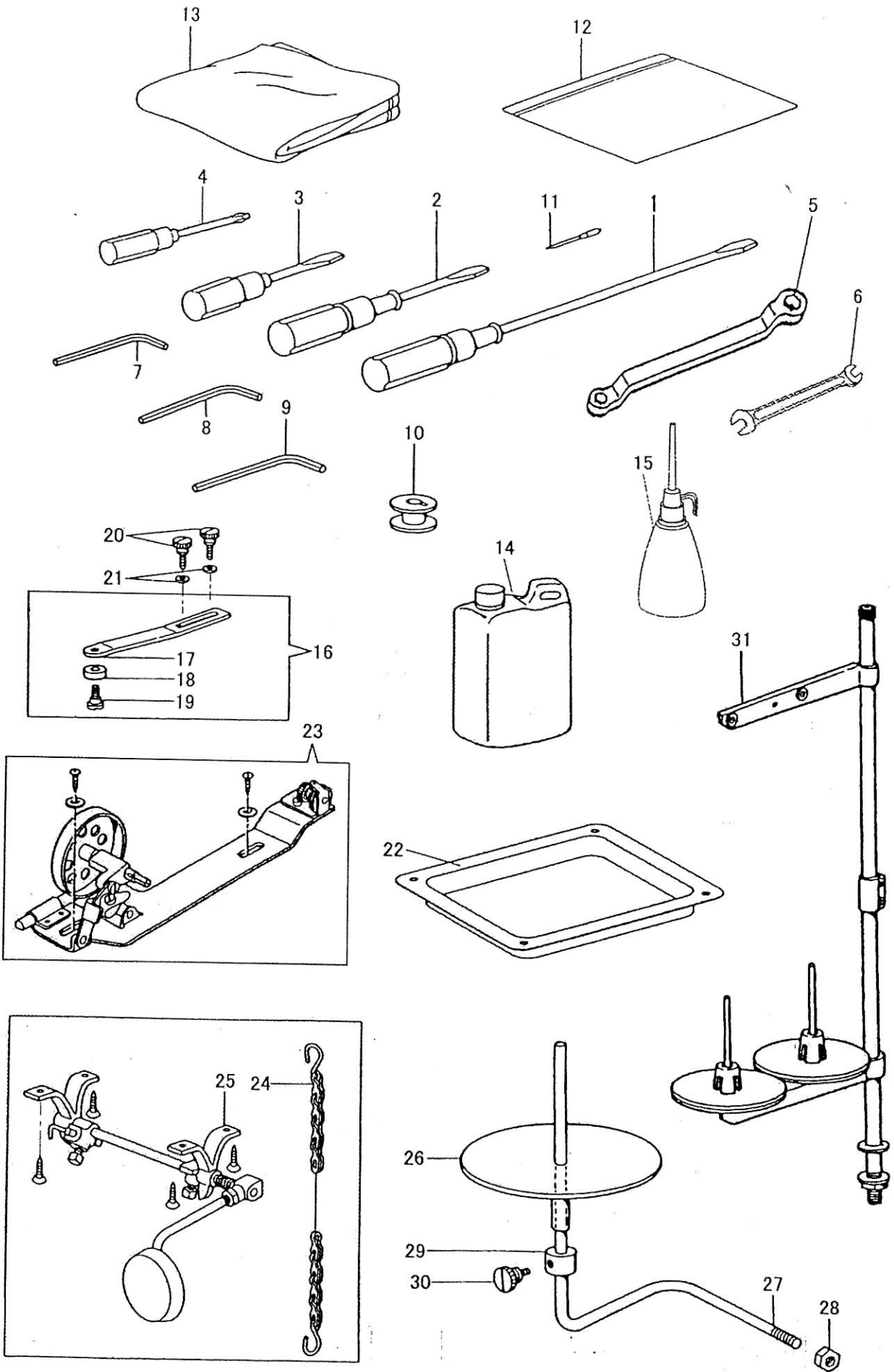

付属品
ACCESSORIES

No.	部品番号 PARTS NO.	8B-2	8BV-2	個数 QTY	品名	DESCRIPTION
1	8118	*	*	1	ドライバー(大)	SCREW DRIVER (LARGE)
2	8120	*	*	1	ドライバー(中)	SCREW DRIVER (MIDDLE)
3	8121	*	*	1	ドライバー(小)	SCREW DRIVER (SMALL)
4	19473	*	*	1	十字ドライバー	SCREW DRIVER (CROSS TYPE)
5	19462	*	*	1	メガネレンチ(10X11)	DOUBLE HEAD WRENCH
6	19461	*	*	1	スパナ(6X7)	SPANNER (6 X 7)
7	19457	*	*	1	六角レンチ(2.5mm)	HEXAGON WRENCH (2.5 mm)
8	19458	*	*	1	六角レンチ(3.0mm)	HEXAGON WRENCH (3.0 mm)
9	19459	*	*	1	六角レンチ(4.0mm)	HEXAGON WRENCH (4.0 mm)
10	17810	*	*	6	ボビン(アルミ)	BOBBIN (ALUMINUM)
11	NO116	-	*	3	針DPX17 #16	NEEDLE DPX17 #16
11	NO118	*	-	3	針DPX17 #18	NEEDLE DPX17 #18
12	8132-A	*	*	1	部品袋	VINYL PACKET
13	8124	*	*	1	ビニールカバー(大)	VINYL COVER
14	11193	*	*	1	油(大)	OIL
15	8125	*	*	1	油差し	OILER
16	17227C	*	-	1	定規組	CLOTH EDGE GUIDE COMP.
17	17227	*	-	1	定規板	CLOTH EDGE GUIDE PLATE
18	17228	*	-	1	定規ローラー	CLOTH EDGE GUIDE ROLER
19	17229	*	-	1	定規ローラー段ねじ	CLOTH EDGE GUIDE SCREW
20	7047	*	-	2	定規止	SCREW 9/64X40 L=12
21	30025	*	-	2	定規止ワッシャー	WASHER
22	17866	*	*	1	油受	OIL PAN
23	19465	*	*	1	糸巻きセット	BOBBIN WINDER COMPLETE
24	17082	*	*	1	くさり 500L	CHAIN (500 m/m) WITH HOOK
25	17081	*	*	1	膝上げセット	KNEE LIFTER COMPLETE
26	13260	-	*	1	テープ受板	TAPE STAND
27	13263	-	*	1	テープ受板棒	TAPE STAND BAR
28	13264	-	*	1	テープ受板棒ナット	TAPE STAND BAR NUT
29	13261	-	*	1	テープ受板カラー	TAPE STAND BAR COLLAR
30	7047	-	*	1	テープ受板カラー止	SCREW 9/64X40 L=12
31	35254	*	*	1	糸立セット	THREAD STAND COMPLETE

SEIKO SEWING MACHINE CO., LTD.

2-13-6 Sakaecho, Funabashi-shi Chiba Prefecture,
273-0018, Japan

TEL: 81-47-420-3561 (Overseas dept.)

FAX: 81-47-420-3560

E-mail: export@seiko-sewing.co.jp

<http://www.seiko-sewing.co.jp/>

セイコーミシン株式会社

〒273-0018 千葉県船橋市栄町2-13-6

TEL: 047-420-3561, IP電話: 050-3535-3491

FAX: 047-420-3560

E-mail: eigyo@seiko-sewing.co.jp

(国内営業)

Parts No. PB84300 (0213)