

SEIKO

パーツリスト
PARTS LIST

LSWN-28BL-2
LSWN-28BL/TA-2

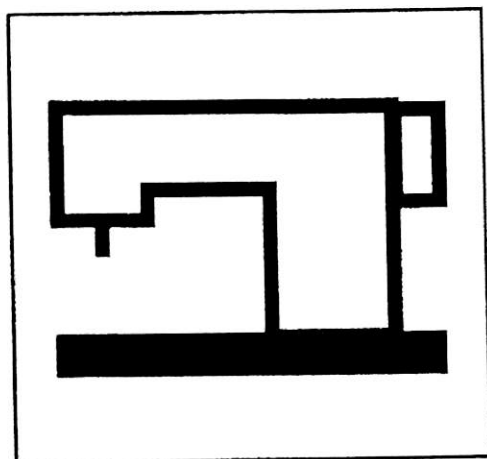

SEIKO SEWING MACHINE CO., LTD.

目次
CONTENTS

	Page
面板、裏板 FACE PLATE, ARM COVER (REAR)	1, 2
上板 ARM TOP COVER	3, 4
天秤、上軸、プーリー THREAD TAKE-UP LEVER, ARM SHAFT, MACHINE PULLEY	5, 6
押え棒、中押え棒 PRESSER BAR, VIBRATING PRESSER BAR	7, 8
針棒土台、連結ロッド NEEDLE BAR ROCK FRAME, ROCK SHAFT CRANK CONNECTION	9, 10
大弓、押え棒大板ばね KNEE LIFTER LIFTING LEVER, PRESSER BAR SPRING	11, 12
下軸、下ベルトプーリー、送りカム HOOK DRIVING SHAFT, SAFETY CLUTCH PULLEY, FEED DRIVING ECCENTRIC	13, 14
針板、送り土台、送り軸 THROAT PLATE, FEED BAR, FEED DRIVING ROCK SHAFT	15, 16
バックレバー、送り調節機構 FEED REVERSE LEVER, FEED REGULATING MECHANISM	17, 18
かま土台(右)、かま HOOK SADDLE (RIGHT), HOOK	19, 20
かま土台(左)、かま HOOK SADDLE (LEFT), HOOK	21, 22
調子板 TENSION BRACKET	23, 24
潤滑 LUBRICATION	25, 26
糸巻き BOBBIN WINDER	27, 28
付属品1 ACCESSORIES 1	29, 30
付属品2 ACCESSORIES 2	31, 32
ゲージ表 TABLE OF GAUGE PARTS	33, 34

面板、裏板
FACE PLATE, ARM COVER (REAR)

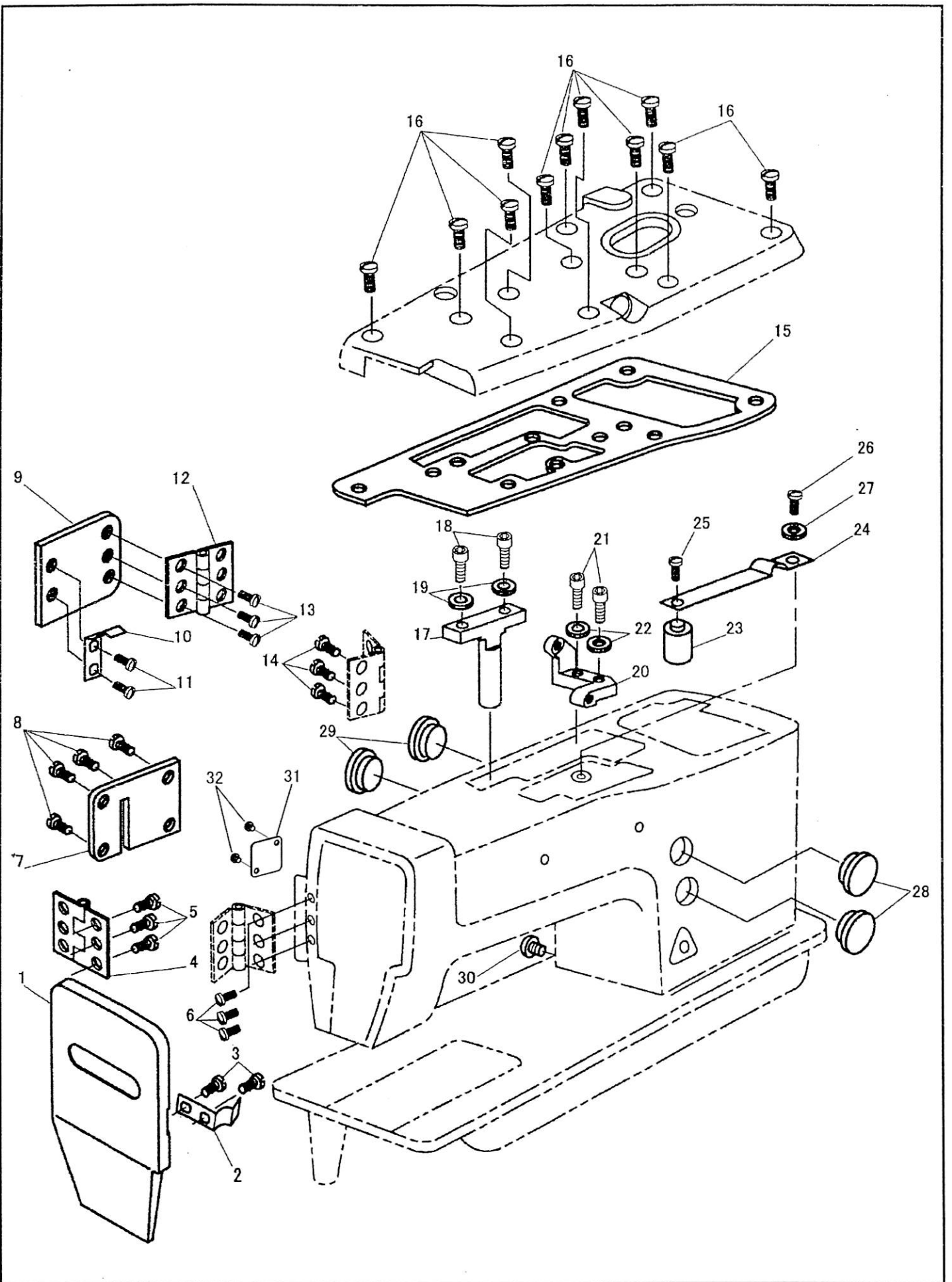

面板、裏板
FACE PLATE, ARM COVER (REAR)

No	部品番号 PARTS No	-28BL-2 -28BL/TA-2	員数 QTY	品名	DESCRIPTION
1	40102	* * *	1	面板	FACE PLATE
2	15037	* * *	1	面板バネ	FACE PLATE SPRING
3	15039	* * *	2	面板バネ止めねじ	SCREW 1/8X44 L=3.5
4	15036	* * *	1	面板蝶番	HINGE
5	15039	* * *	3	面板蝶番止めねじ	SCREW 1/8X44 L=3.5
6	15039	* * *	3	面板止めねじ	SCREW 1/8X44 L=3.5
7	40106	* * *	1	裏板 (面板側)	ARM COVER (REAR) (SMALL)
8	8040	* * *	4	裏板 (面板側) 止めねじ	SCREW 9/64X40 L=8.0
9	40105	* * *	1	裏板 (プーリ側)	ARM COVER (REAR) (LARGE)
10	15037	* * *	1	裏板 (プーリ側) バネ	ARM COVER (REAR) (LARGE) SPRING
11	15039	* * *	2	裏板 (プーリ側) バネ止めねじ	SCREW 1/8X44 L=3.5
12	15036	* * *	1	裏板 (プーリ側) 蝶番	HINGE
13	15039	* * *	3	裏板 (プーリ側) 蝶番止めねじ	SCREW 1/8X44 L=3.5
14	15039	* * *	3	裏板 (プーリ側) 止めねじ	SCREW 1/8X44 L=3.5
15	40104	* * *	1	上板シート パッキン	GASKET
16	30066	* * *	11	上板止めねじ	SCREW M5X0.8 L=12
17	40100-02	* * *	1	大板ばね調節ねじ土台	P/B SPRING REGULATING SCREW BRACKET
18	18065	* * *	2	土台止めねじ	SCREW M5X0.8 L=14
19	90625	* * *	2	土台止めねじ座金	WASHER
20	25600	* * *	1	小弓土台	KNEE LIFTER CONNECTING LEVER BRACKET
21	18065	* * *	2	小弓土台止めねじ	SCREW M5X0.8 L=14
22	90625	* * *	2	小弓土台止めねじ座金	WASHER
23	11004	* * *	1	油調節おもり	OIL REGULATOR
24	15086	* * *	1	油調節板バネ	OIL CONTROL SPRING
25	10597	* * *	1	油調節おもり止めねじ	SCREW 1/8X40 L=3.3
26	8040	* * *	1	油調節板バネ止めねじ	SCREW 9/64X40 L=8.0
27	11142	* * *	1	油調節板バネ止めねじワッシャー	WASHER
28	40118	* * *	2	アームゴム栓 (径20)	RUBBER
29	40118	* * *	2	アームゴム栓 (径20)	RUBBER
30	30046	* * *	1	アース線止めねじ	EARTH WIRE SCREW M4X0.7 L=4
31	40266	* * *	1	アーム裏カバー	ARM SIDE COVER (REAR)
32	37509	* * *	2	アーム裏カバー止めねじ	SCREW M5X0.8 L=6.0

上板
ARM TOP COVER

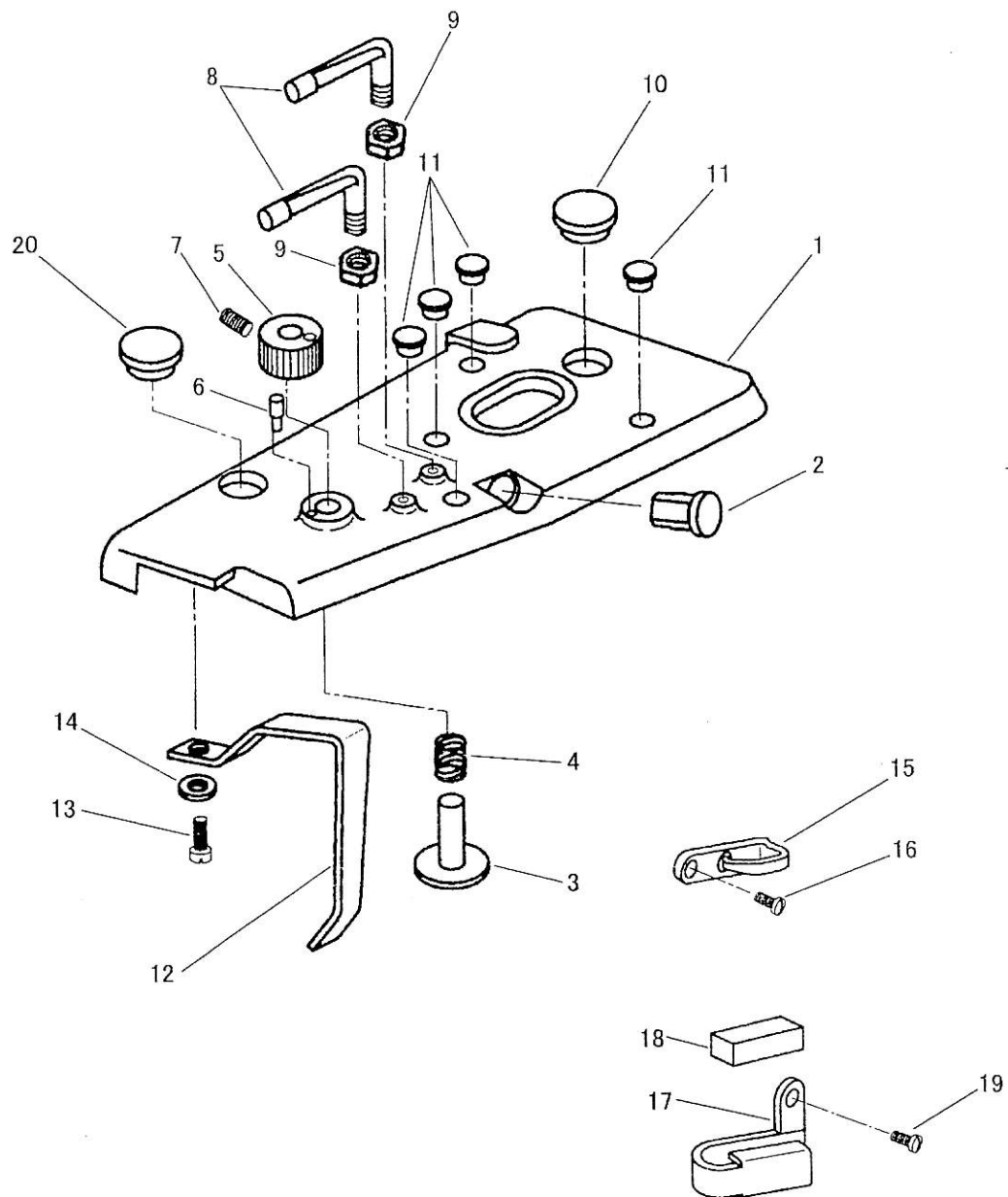

上板
ARM TOP COVER

No	部品番号 PARTS No	-28BL-2	-28BL/TA-2	員数 QTY	品名	DESCRIPTION
1	40103	*	*	1	上板	ARM TOP COVER
2	11007	*	*	1	油量のぞき窓	OIL LEVEL INDICATOR
3	15058	*	*	1	給油遮断軸	OIL REGULATING STUD
4	15059	*	*	1	給油遮断スプリング	OIL REGULATING STUD SPRING
5	15057	*	*	1	給油遮断ダイヤル	OIL REGULATING DIAL
6	15061	*	*	1	給油遮断ピン	PIN
7	8009	*	*	1	給油遮断ダイヤル止めねじ	SCREW 15/64X28 L=7.5
8	11006	*	*	2	上板糸掛	ARM TOP COVER THREAD GUIDE
9	13076-02	*	*	2	上板糸掛ナット	NUT
10	40118	*	*	1	上板ゴム栓 (径20)	RUBBER
11	40119	*	*	4	上板ゴム栓 (径9)	RUBBER
12	40123	*	*	1	天秤カバー	THREAD TAKE-UP LEVER COVER
13	27174	*	*	1	天秤カバー止めねじ	SCREW M4X0.7 L=10.0
14	31208	*	*	1	天秤カバー止めねじ座金	SPRING WASHER
15	10682	*	*	1	面糸掛け(上)	THREAD GUIDE (UPPER)
16	19510	*	*	1	面糸掛け(上) 止めねじ	SCREW 9/64X40 L=6.5
17	10759-A	*	*	1	面糸掛け(下)	THREAD GUIDE (LOWER)
18	10760	*	*	1	面糸掛け(下) フェルト	FELT
19	19510	*	*	1	面糸掛け(下) 止めねじ	SCREW 9/64X40 L=6.5
20	40118	*	*	1	上板ゴム栓 (径20)	RUBBER

天秤、上軸、プーリー
 THREAD TAKE-UP LEVER, ARM SHAFT, MACHINE PULLEY

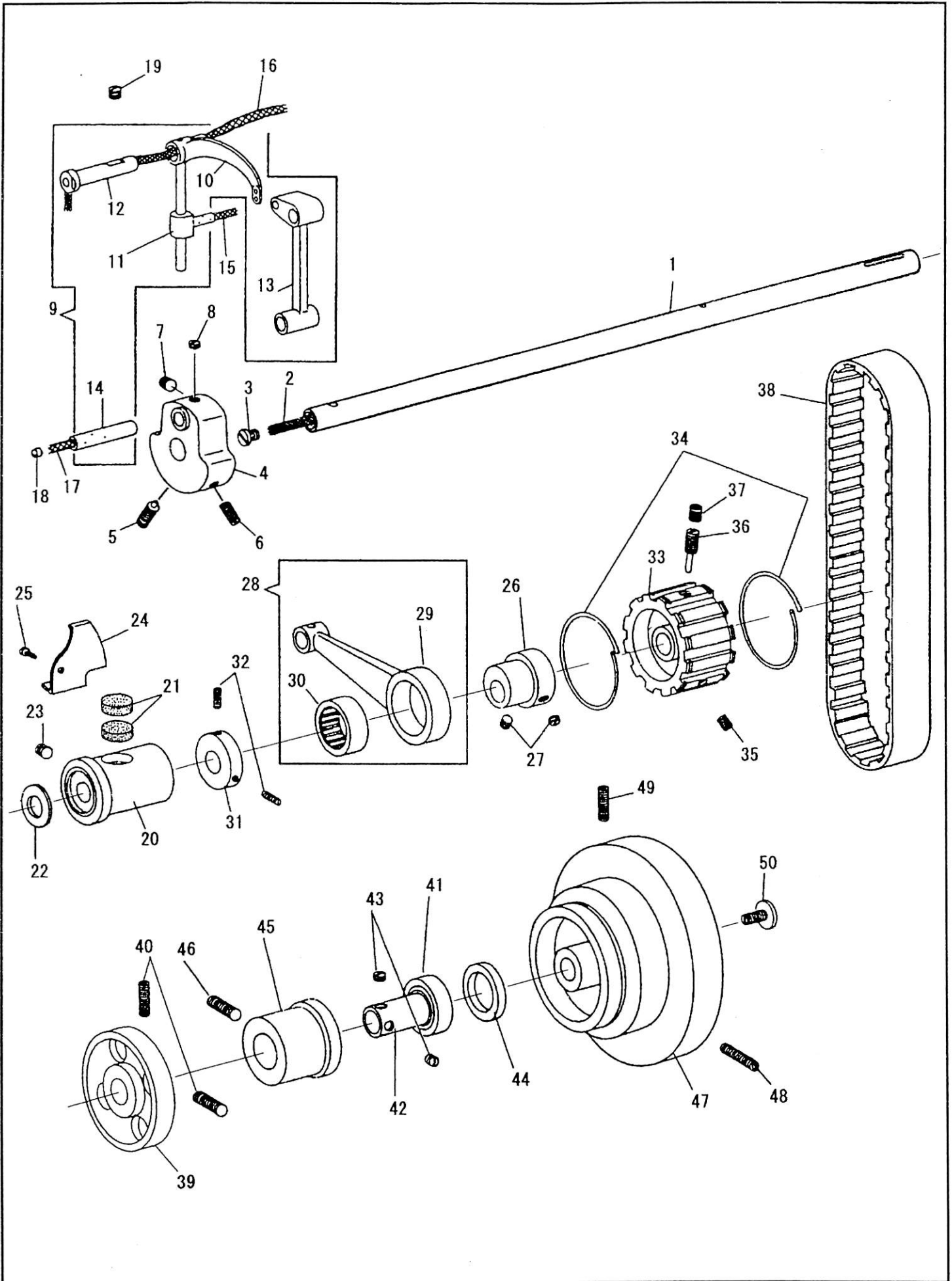

天秤、上軸、プーリー

THREAD TAKE-UP LEVER, ARM SHAFT, MACHINE PULLEY

No	部品番号 PARTS No	-28BL-2 -28BL/TA-A-2	員数 QTY	品名	DESCRIPTION
1	25601	*	1	上軸	ARM SHAFT
2	11042	*	1	上軸油芯	OIL WICK
3	19504	*	1	上軸油芯止めねじ	OIL STOP SCREW 5/16X28 L=6.0
4	19414	*	1	クランクモーション カム	CRANK MOTION CAM
5	19415	*	1	位置決めねじ	POSITION SCREW 1/4X28 L=20.0
6	19416	*	1	止めねじ	SET SCREW 1/4X28 L=14.0
7	19417	*	1	針棒クランクピン止めねじ (長)	SET SCREW (LONG) 1/4X28 L=6.5
8	19418	*	1	針棒クランクピン止めねじ (短)	SET SCREW (SHORT) 1/4X28 L=4.5
9	34105C	*	1	天秤 (組)	THREAD TAKE-UP LEVER COMP.
9	15503C	-	1	天秤 (組)	THREAD TAKE-UP LEVER COMP.
10	34105	*	1	天秤	THREAD TAKE-UP LEVER
10	15503	-	1	天秤	THREAD TAKE-UP LEVER
11	15026	*	1	天秤抱き	THREAD TAKE-UP LEVER DRIVING STUD
12	15013	*	1	天秤ピン	THREAD TAKE-UP LEVER HINGE STUD
13	10528	*	1	針棒クランク	NEEDLE BAR CONNECTING LINK
14	10523	*	1	針棒クランクピン	NEEDLE BAR CONNECTING LINK STUD
15	10728	*	1	天秤抱き油芯	OIL WICK
16	11042	*	1	天秤ピン油芯	OIL WICK
17	10726	*	1	針棒クランクピン油芯	OIL WICK
18	15038	*	1	油ゴム栓	RUBBER OIL STOPPER
19	25179	*	1	天秤ピン止めねじ	SET SCREW 17/64X32 L=9.0
20	18006	*	1	上軸メタル (前)	ARM SHAFT BUSHING (FRONT)
21	10725	*	2	上軸メタル (前) フェルト	OIL FELT
22	10563	*	1	上軸メタル (前) ワッシャー	WASHER
23	19417	*	1	上軸メタル (前) 止めねじ	SET SCREW 1/4X28 L=6.5
24	10551	*	1	天秤油受け	THREAD TAKE-UP LEVER OIL GUARD
25	3052	*	1	天秤油受け止めねじ	SCREW 9/64X40 L=4.5
26	19427	*	1	中押え上下カム	LIFTING ECCENTRIC (ECC. 4.0)
26	17100	-	1	中押え上下カム	LIFTING ECCENTRIC (ECC. 5.0)
27	19508	*	2	中押え上下カム止めねじ	SET SCREW 1/4X40 L=5.5
27	10566	-	2	中押え上下カム止めねじ	SET SCREW 1/4X32 L=5.5
28	10772C	*	1	上連結ロッド (組)	LIFTING ECCENTRIC CONNECTION COMP.
29	10772	*	1	上連結ロッド	LIFTING ECCENTRIC CONNECTION
30	10773	*	1	上連結ロッドニードルベアリング	NEEDLE BEARING
31	11879	*	1	中押え上下カムカラー	LIFTING ECCENTRIC COLLAR
32	10573	*	2	中押え上下カムカラー止めねじ	SET SCREW 7/32X32 L=11.0
33	25192	*	1	ベルトプーリー	ARM SHAFT CONNECTING BELT PULLEY
34	10574	*	2	ベルトプーリーリング	BELT PULLEY SPRING FLANGE
35	17019-A	*	1	ベルトプーリー止めねじ	SET SCREW 1/4X40 L=7.5
36	25619	*	1	ベルトプーリーピンねじ	POSITION SCREW 1/4X40
37	17019-A	*	1	ベルトプーリーピンねじ止めねじ	POSITION SCREW SET SCREW 1/4X40 L=7.5
38	10621	*	1	タイミング ベルト	ARM SHAFT CONNECTING BELT
39	40130	*	1	糸巻きカラー	BOBBIN WINDER COLLAR
40	27171	*	2	糸巻きカラー止めねじ	SET SCREW
41	10567	*	1	上軸ベアリング	ARM SHAFT BALL BEARING
42	40133	*	1	上軸ベアリングカラー	ARM SHAFT BALL BEARING ADAPTER SLEEVE
43	23637	*	2	上軸ベアリングカラー止めねじ	SET SCREW 1/4X28 L=7.5
44	10568	*	1	上軸ベアリングリング (溝なし)	BALL BEARING RETAINING RING
45	40134	*	1	上軸ベアリングケース	ARM SHAFT BALL BEARING ADAPTER
46	25170	*	1	上軸ベアリングケース止めねじ	SET SCREW 17/64X32 L=20.0
47	15162-A	*	1	プーリー	MACHINE PULLEY
48	10576	*	1	プーリー位置決めねじ	POSITION SCREW 15/64X28 L=21.0
49	10579	*	1	プーリー止めねじ	SET SCREW 15/64X28 L=20.0
50	19505	*	1	プーリー押ねじ	MACHINE PULLEY ADJUSTING SCREW 11/32X28 L=11.0

押え棒、中押え棒
 PRESSER BAR, VIBRATING PRESSER BAR

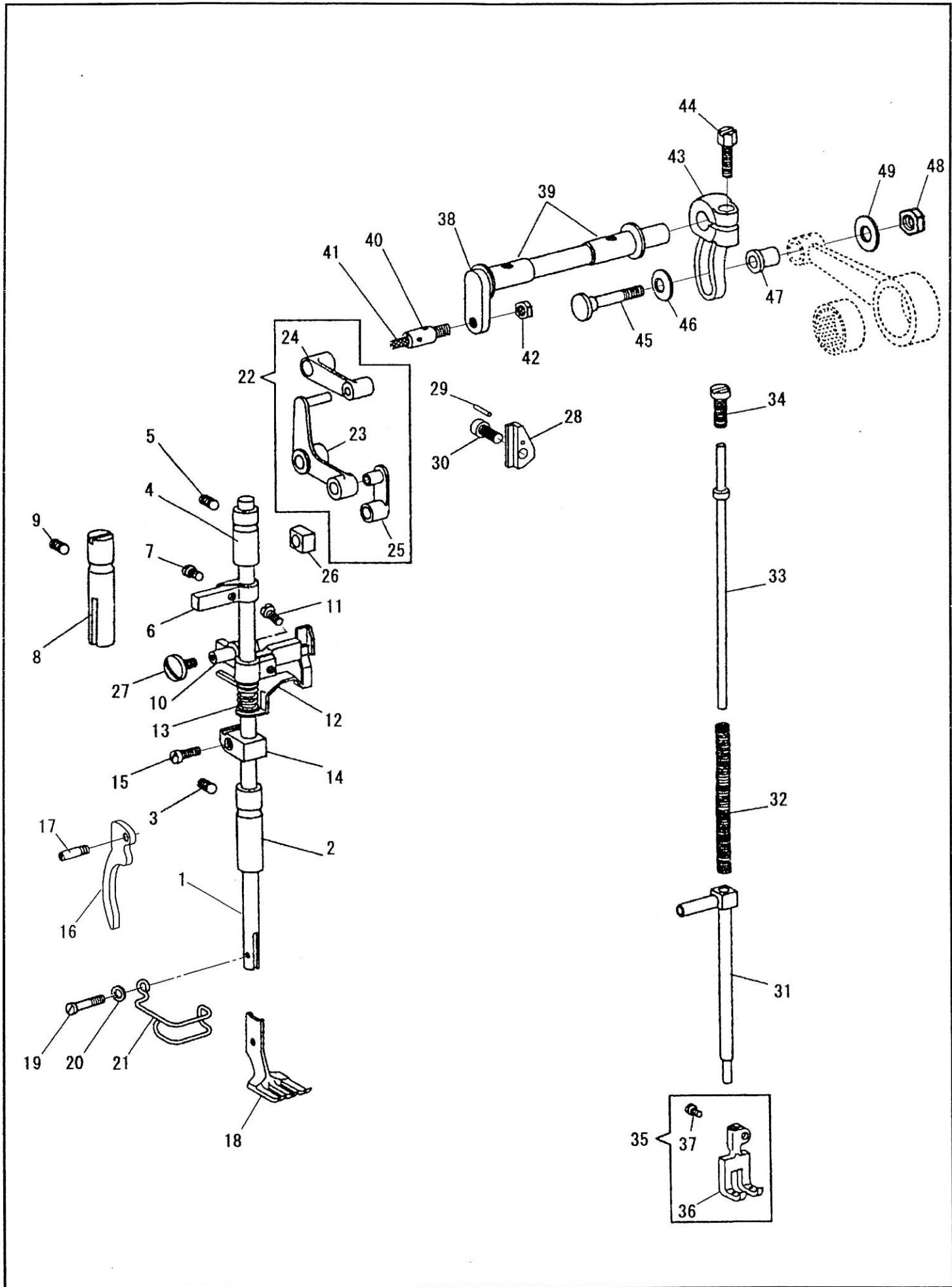

押え棒、中押え棒
PRESSER BAR, VIBRATING PRESSER BAR

No	部品番号 PARTS No			員数 QTY	品名	DESCRIPTION
		-28BL-2	-28BL/TA-2			
1	18477	*	*	1	押え棒	PRESSER BAR
2	10539-A	*	*	1	押え棒メタル (下)	PRESSER BAR BUSHING (LOWER)
3	25163	*	*	1	押え棒メタル (下) 止めねじ	SET SCREW 17/64X32 L=11.0
4	10538	*	*	1	押え棒メタル (上)	PRESSER BAR BUSHING (UPPER)
5	25163	*	*	1	押え棒メタル (上) 止めねじ	SET SCREW 17/64X32 L=11.0
6	25208	*	*	1	押え棒案内	PRESSER BAR POSITION GUIDE BRACKET
7	25209	*	*	1	押え棒案内止めねじ	SET SCREW 9/64X40
8	10543	*	*	1	案内棒	PRESSER BAR POSITION GUIDE
9	25163	*	*	1	案内棒止めねじ	SET SCREW 17/64X32 L=11.0
10	18479	*	*	1	押え棒抱き	PRESSER BAR LIFTING BRACKET
11	19518	*	*	1	押え棒抱き締めねじ	PINCH SCREW 11/64X40 L=14.0
12	10546-A	*	*	1	押え棒抱き下板	TENSION RELEASE SLIDE
13	10547	*	*	1	押え棒抱き下板ばね	TENSION RELEASE SLIDE SPRING
14	13360	*	*	1	押え棒抱きリング	PRESSER BAR SPRING BRACKET
15	13365	*	*	1	押え棒抱きリング締めねじ	PINCH SCREW M4X0.7 L=9.0
16	40407	*	*	1	押え上げレバー	PRESSER BAR LIFTER
17	25164	*	*	1	押え上げレバーピンねじ	HINGE SCREW 11/64X40
18	10185	*	-	1	外押え (1/4") (標準)	LIFTING PRESSER FOOT (1/4") (Std.)
18	10185-TA	-	*	1	外押え (1/4") (標準)	LIFTING PRESSER FOOT (1/4") (Std.)
19	18484	*	*	1	外押え止めねじ	SCREW 9/64X40 L=10.0
20	10677	*	*	1	外押え止めねじワッシャー	WASHER
21	10937-01	*	*	1	フィンガーガード (1/4") (標準)	FINGER GUARD (1/4") (Std.)
22	10558C	*	*	1	くの字セット	LIFTING BELL CRANK COMP.
23	10558	*	*	1	くの字	LIFTING BELL CRANK
24	10557	*	*	1	くの字連結 (大)	LIFTING BELL CRANK LINK
25	10556	*	*	1	くの字連結 (小)	VIBRATING PRESSER BAR CONNECTING LINK
26	15118	*	*	1	振れ止角玉	VIBRATING PRESSER BAR SLIDE BLOCK
27	18480	*	*	1	くの字止めねじ	LIFTING BELL CRANK SCREW 11/64X40 L=8.0
28	10548-A	*	*	1	押え棒抱き振れ止め板	P/B, LIFTING BRACKET GUIDE BLOCK
29	15111	*	*	1	押え棒抱き振れ止め板ピン	POSITIONING PIN
30	19408	*	*	1	押え棒抱き振れ止め板止めねじ	SCREW 1/4X28 L=17.5
31	34713	*	*	1	中押え棒	VIBRATING PRESSER BAR
32	10554	*	*	1	中押え棒スプリング	VIBRATING PRESSER BAR EXTENSION SPRING
33	10553-A	*	*	1	中押え棒スプリング棒	VIBRATING PRESSER BAR EXTENSION
34	15060	*	*	1	中押え棒押しねじ	SCREW 5/16X24 L=16.0
35	10285C	*	-	1	中押え (組) (標準)	VIBRATING PRESSER FOOT COMP. (Std.)
35	10285-CA	-	*	1	中押え (組) (標準)	VIBRATING PRESSER FOOT COMP. (Std.)
36	10285	*	-	1	中押え (1/4") (標準)	VIBRATING PRESSER FOOT (1/4") (Std.)
36	10285-TA	-	*	1	中押え (1/4") (標準)	VIBRATING PRESSER FOOT (1/4") (Std.)
37	10662	*	*	1	中押え止めねじ	PINCH SCREW 5/32X40 L=6.5
38	19425	*	*	1	横軸	LIFTING ROCK SHAFT
39	10514	*	*	2	横軸メタル	LIFTING ROCK SHAFT BUSHING
40	16709	*	*	1	横軸ピンねじ	SCREW 1/4X28
41	10728	*	*	1	横軸ピンねじ油芯	OIL WICK
42	19516	*	*	1	横軸ピンねじナット	NUT 1/4X28
43	40107	*	*	1	上下連結だるま	LIFTING ECCENTRIC CONNECTING CRANK
44	19420	*	*	1	上下連結だるま締めねじ	PINCH SCREW 1/4X28 L=16.0
45	10775	*	*	1	上連結ロッド段ねじ	HINGE SCREW 7/32X32
46	35118	*	*	1	上連結ロッド段ねじワッシャー	WASHER
47	10774	*	*	1	上連結ロッドパイプ	LIFTING ECCENTRIC CONNECTION COLLAR
48	17114	*	*	1	上連結ロッド段ねじナット	NUT 7/32X32
49	37215	*	*	1	上連結ロッド段ねじ座金	WASHER

針棒土台、連結ロッド
NEEDLE BAR ROCK FRAME, ROCK SHAFT CRANK CONNECTION

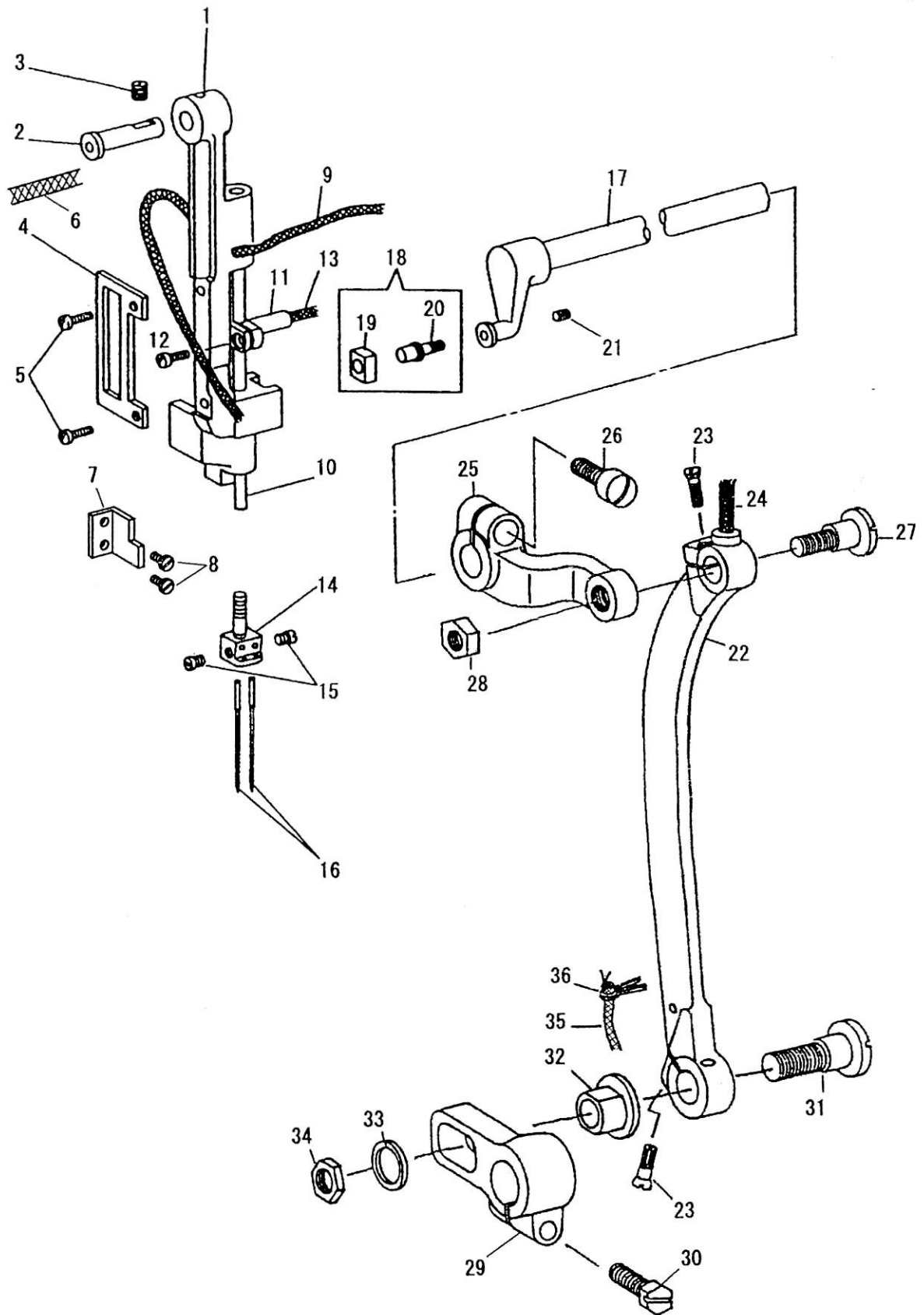

針棒土台、連結ロッド

NEEDLE BAR ROCK FRAME, ROCK SHAFT CRANK CONNECTION

No	部品番号 PARTS No	-28BL-2 -28BL/TA-2	員数 QTY	品名	DESCRIPTION
1	15547-A	**	1	針棒土台	NEEDLE BAR ROCK FRAME
2	11875	**	1	針棒土台ピン	HINGE STUD
3	25179	**	1	針棒土台ピン止めねじ	SET SCREW 17/64X32 L=9.0
4	15117	**	1	針棒土台振れ止板	SLIDE BLOCK PLATE
5	8100	**	2	針棒土台振れ止板止めねじ	SCREW 9/64X40 L=6.5
6	15031	**	1	針棒土台油芯	OIL WICK
7	34037	**	1	イケール	NEEDLE BAR ROCK FRAME POSITION BRACKET
8	15007	**	2	イケール止めねじ	SCREW 9/64X40 L=10.0
9	10728	**	1	針棒土台ピン油芯	OIL WICK
10	10955	**	1	針棒	NEEDLE BAR
11	25637	**	1	針棒抱き	NEEDLE BAR CONNECTING STUD
12	13365	**	1	針棒抱き締めねじ	PINCH SCREW M4X0.7 L=9.0
13	10726	**	1	針棒抱き油芯	OIL WICK
14	25681-04	**	1	針株 (1/4") (標準)	NEEDLE CLAMP (1/4") (Std.)
15	B140553	**	2	針止めねじ	NEEDLE SET SCREW 1/8X40 L=4.5
16	N0122	* -	2	針 DPX17 #22	NEEDLE DPX17 #22
16	N0124	- *	2	針 DPX17 #24	NEEDLE DPX17 #24
17	10578	**	1	上送り竿	NEEDLE BAR ROCK FRAME ROCK SHAFT
18	11876C	**	1	上送り竿角玉 (組)	SLIDE BLOCK COMP.
19	11877	**	1	上送り竿角玉	SLIDE BLOCK
20	11876	**	1	上送り竿ピンねじ	SLIDE BLOCK STUD
21	10581	**	1	上送り竿ピンねじ止めねじ	SCREW 7/32X32 L=7.0
22	34021	**	1	連結ロッド	ROCK SHAFT CRANK CONNECTION
23	34022	**	2	連結ロッド調節ねじ	ADJUSTING SCREW 9/64X40
24	10728	**	1	連結ロッド油芯	OIL WICK
25	25602	**	1	連結	ROCK SHAFT CRANK
26	25603	**	1	連結締めねじ	PINCH SCREW 1/4X24
27	34023	**	1	連結ロッド 小 段ねじ	HINGE SCREW 9/32X28
28	8105	**	1	連結ロッド 小 段ねじナット	NUT 9/32X28
29	15019	**	1	送り竿後だるま	FEED ROCK SHAFT CRANK
30	10754	**	1	送り竿後だるま締めねじ	PINCH SCREW 6.75X24 L=16.0
31	34024	**	1	連結ロッド 大 段ねじ	HINGE SCREW 5/16X28
32	34026	**	1	送り調節パイプ	FEED ROCK SHAFT CRANK PIPE
33	34025	**	1	連結ロッド 大 段ねじワッシャー	WASHER
34	50155	**	1	連結ロッド 大 段ねじナット	NUT
35	10778	**	1	油芯	OIL WICK
36	10779	**	1	油芯押え割ピン	CLIP