

SEIKO

パーツリスト
PARTS LIST

LZ2-770-3N

LZ2-772-3N

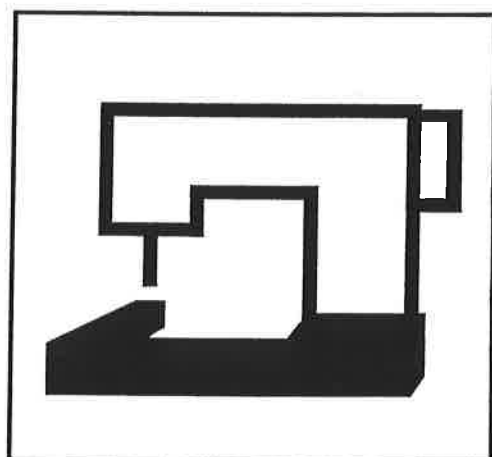

SEIKO SEWING MACHINE CO., LTD.

目次
CONTENTS

	Page
上板、面板 ARM TOP COVER, FACE PLATE	1, 2
ベッドカバー、送り軸カバー BED COVER, FEED ROCK SHAFT COVER	3, 4
上軸、針棒土台 ARM SHAFT, NEEDLE BAR ROCK FRAME	5, 6
押え棒、押え上げレバー PRESSER BAR, PRESSER FOOT LIFTING LEVER	7, 8
針振りカム、針振り調節ダイヤル ZIGZAG CAM, ZIGZAG ADJUSTING DIAL	9, 10
送りカム、送り軸 FEED CAM, FEED ROCK SHAFT	11, 12
タイミングベルト、プーリー TIMING BELT, PULLEY	13, 14
下軸、かま LOWER SHAFT, HOOK	15, 16
送り調節、バックレバー FEED REGULATOR, REVERSE LEVER	17, 18
大弓 FOOT LIFTER LIFTING LEVER	19, 20
上送り機構(1) UPPER FEED MECHANISM (1)	21, 22
上送り機構(2) ACCESSORIES (2)	23, 24
付属品1 ACCESSORIES 1	25, 26
付属品2 ACCESSORIES 2	27, 28

上板、面板
ARM TOP COVER, FACE PLATE

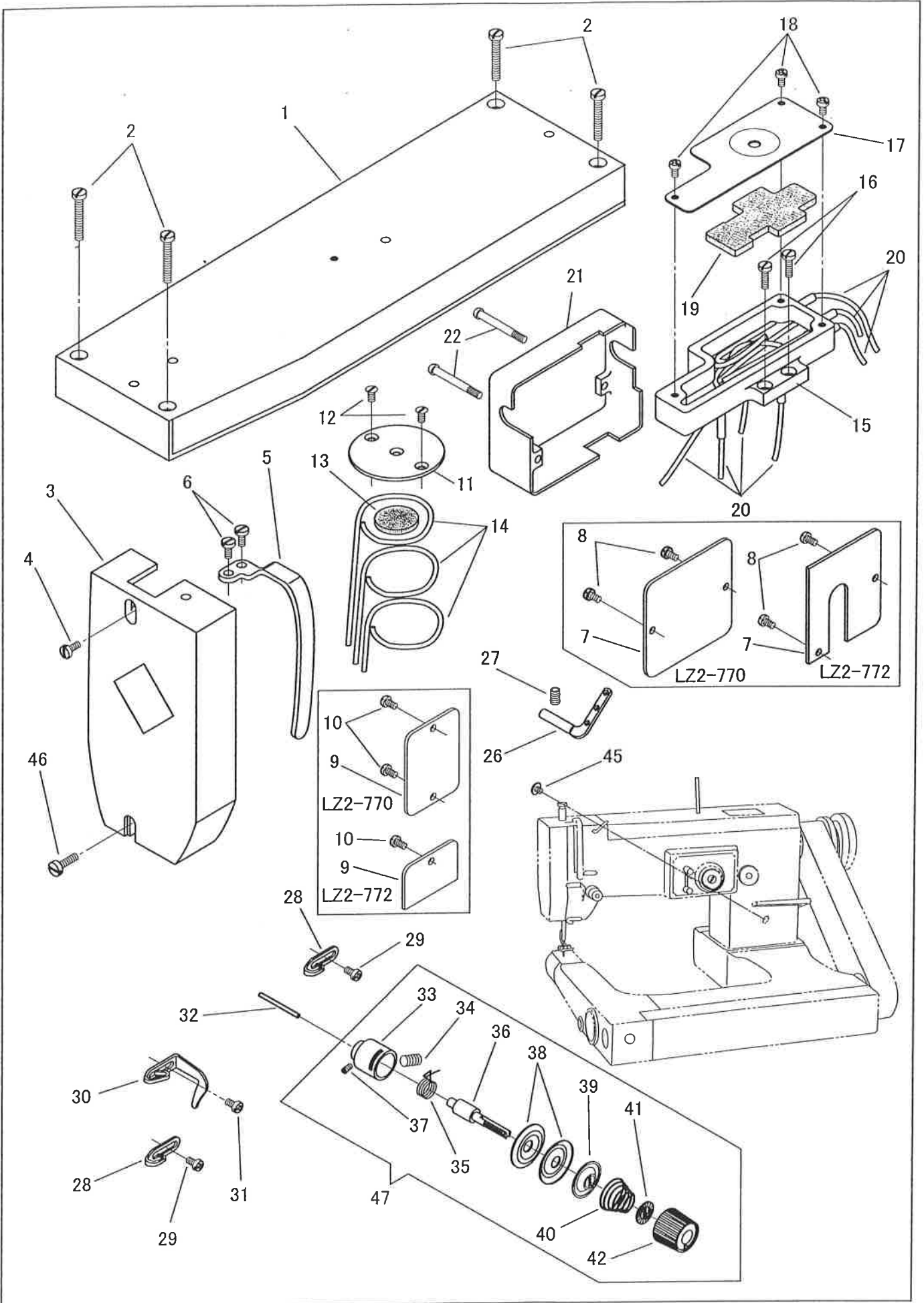

上板、面板

ARM TOP COVER, FACE PLATE

No.	部品番号 PARTS NO.	LZ2-770	LZ2-772	個数 QTY	品名	DESCRIPTION
1	V0001	*	*	1	上板	ARM TOP COVER
2	V0002	*	*	4	ねじ	SCREW
3	41004	*	-	1	面板	FACE PLATE
3	41014	-	*	1	面板	FACE PLATE
4	V0003	*	*	1	ねじ	SCREW
5	V0004	*	*	1	天秤カバー	THREAD TAKE-UP LEVER COVER
6	V0005	*	*	2	ねじ	SCREW
7	V0006	*	-	1	アーム側面カバー(後)	ARM SIDE COVER (REAR)
7	V1301	-	*	1	アーム側面カバー(後)	ARM SIDE COVER (REAR)
8	V0007	*	*	2	ねじ	SCREW
9	V0008	*	-	1	アーム側面カバー(前)	ARM SIDE COVER (FRONT)
9	V1302	-	*	1	アーム側面カバー(前)	ARM SIDE COVER (FRONT)
10	V0009	*	-	2	ねじ	SCREW
10	V0009	-	*	1	ねじ	SCREW
11	V0010	*	*	1	油タンク(前)カバー	OIL TANK (FRONT) COVER
12	V0011	*	*	2	ねじ	SCREW
13	V0012	*	*	1	フェルト	OIL FELT
14	V0013	*	*	3	油芯	OIL WICK
15	V1501	*	*	1	油タンク(後)(組)	OIL TANK (REAR) COMPLETE
16	V0015	*	*	2	ねじ	SCREW
17	V0016	*	*	1	油タンク(後)カバー	OIL TANK (REAR) COVER
18	V0017	*	*	3	ねじ	SCREW
19	V0018	*	*	1	フェルト	OIL FELT
20	V0019	*	*	7	油芯	OIL WICK
21	V1502	*	*	1	針振りカムカバー	ZIG ZAG CAM COVER
22	V1503	*	*	1	ねじ	SCREW
26	V0025	*	*	1	上板糸掛	ARM TOP COVER THREAD GUIDE
27	V0026	*	*	1	ねじ	SCREW
28	V0027	*	*	2	アーム糸掛	ARM THREAD GUIDE
29	14013	*	*	2	ねじ	SCREW 9/64X40 L=5.5
30	V0029	*	*	1	大糸掛	TENSION POST THREAD GUIDE
31	14013	*	*	1	ねじ	SCREW 9/64X40 L=5.5
32	V0031	*	*	1	皿浮かしピン	TENSION RELEASE PIN
33	V0032	*	*	1	糸調子臼	THREAD TAKE-UP SPRING REGULATOR
34	V0033	*	*	1	ねじ	SCREW
35	V0034	*	*	1	糸取りばね	THREAD TAKE-UP SPRING
36	V0035	*	*	1	糸調子棒	TENSION POST
37	V0036	*	*	1	ねじ	SCREW
38	V0037	*	*	2	糸調子皿	TENSION DISC
39	V0038	*	*	1	丸一皿	TENSION RELEASE WASHER
40	V0039	*	*	1	渦巻ばね	SPIRAL SPRING
41	V0040	*	*	1	ラチェット	RATCHET
42	V0041	*	*	1	調整ナット	REGULATING THUMB NUT
45	30046	*	*	1	アース線止めねじ	SCREW M4X0.7
46	V0249	*	*	1	ねじ	SCREW
47	V0032C	*	*	1	糸調子(組)	TENSION REGULATOR COMPLETE

ベッドカバー、送り軸カバー
BED COVER, FEED ROCK SHAFT COVER

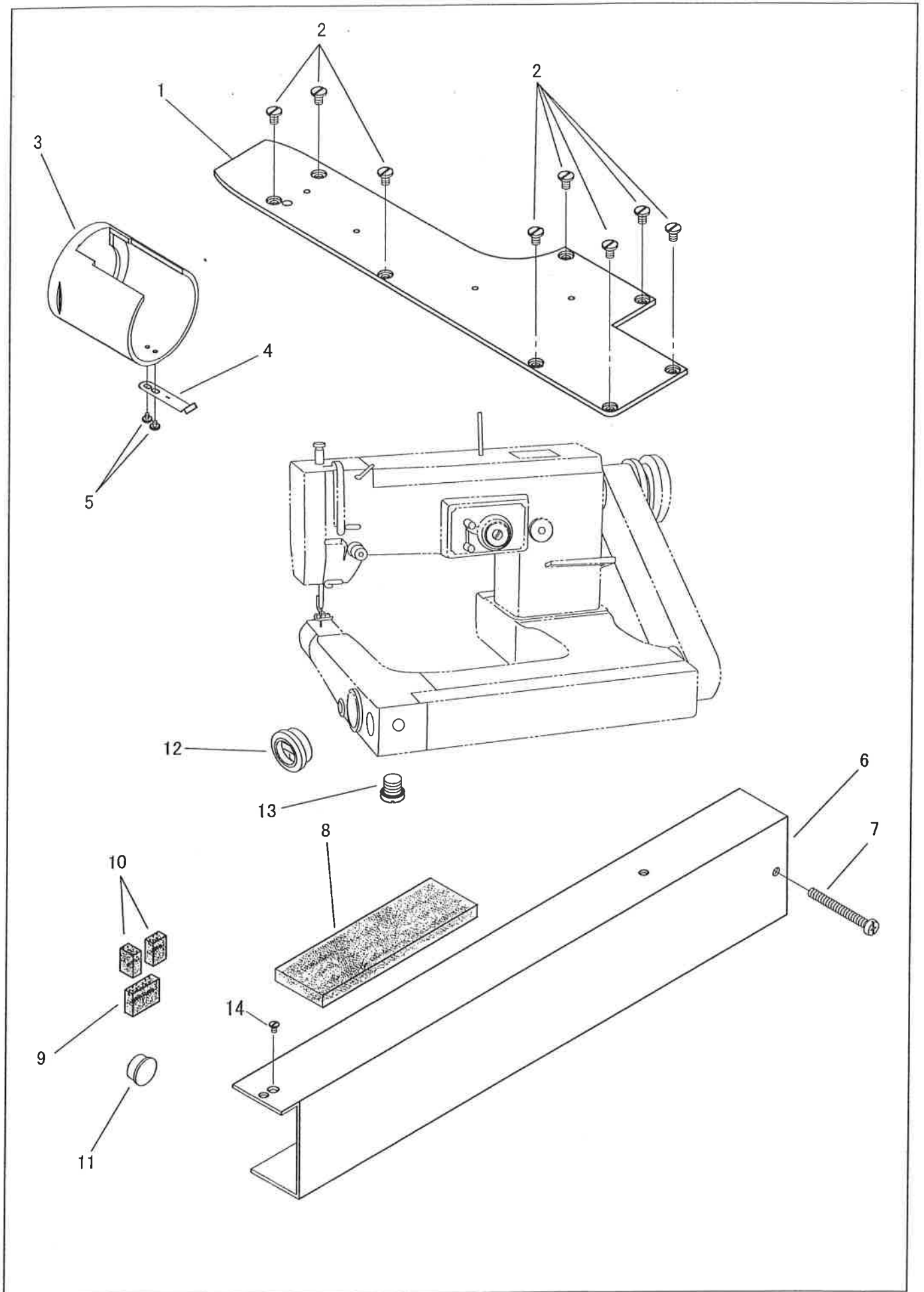

ベッドカバー、送り軸カバー

BED COVER, FEED ROCK SHAFT COVER

No.	部品番号 PARTS NO.	LZ2-770	LZ2-772	個数 QTY	品名	DESCRIPTION
1	V1001-A	*	*	1	ベッドカバー	BED COVER
2	V1002	*	*	5	ねじ	SCREW
3	V1003	*	*	1	シリンダーカバー	BED END COVER
4	V1004	*	*	1	シリンダーカバーばね	BED END COVER SPRING
5	V1005	*	*	2	ねじ	SCREW
6	V1006-A	*	*	1	送り軸カバー	FEED ROCK SHAFT COVER
7	V1007	*	*	1	ねじ	SCREW
8	V1008	*	*	1	送り軸カバーフェルト	FEED ROCK SHAFT COVER OIL ABSORPTION FELT
9	V1009	*	*	1	フェルト(大)	OIL RETAINING FELT (LARGE)
10	V1010	*	*	2	フェルト(小)	OIL RETAINING FELT (SMALL)
11	V1011	*	*	1	ゴム栓	RUBBER CAP
12	V1012	*	*	1	油量表示器	OIL LEVEL INDICATOR
13	V1013	*	*	1	油抜きねじ	OIL DRAIN PLUG
14	13384	*	*	1	ねじ	SCREW

上軸、針棒土台

ARM SHAFT, NEEDLE BAR ROCK SHAFT

No.	部品番号 PARTS NO.	LZ2-770	LZ2-772	個数 QTY	品名	DESCRIPTION
1	V1126	*	*	1	上軸	ARM SHAFT
9	V1504	*	*	1	針振り小ギヤー	ZIGZAG GEAR (SMALL)
10	V0051	*	*	2	ねじ	SCREW
11	V0052	*	*	1	上軸カラー	ARM SHAFT COLLAR
12	V0053	*	*	2	ねじ	SCREW
13	V0054	*	*	1	上軸メタル(前)	ARM SHAFT BUSHING (FRONT)
14	V0055	*	*	1	ねじ	SCREW
15	V0056	*	*	1	クランクモーションカム	CRANK MOTION CAM
16	V0057	*	*	1	ねじ	SCREW
17	V0058	*	*	1	ねじ	SCREW
18	V0059	*	*	1	ねじ	SCREW
19	V0060C	*	*	1	天秤(組)	THREAD TAKE-UP LEVER COMPLETE
20	V0062	*	*	1	ねじ	SCREW
23	V0064	*	*	1	ねじ	SCREW
24	V0065	*	*	1	針棒土台	NEEDLE BAR ROCK FRAME
25	V0066	*	*	1	針棒土台ピン	NEEDLE BAR ROCK FRAME HINGE STUD
26	V0067	*	*	1	ねじ	SCREW
27	V0068	*	-	1	針棒土台押え	NEEDLE BAR ROCK FRAME GUIDE PIN
28	V0069	*	-	1	ねじ	SCREW
29	V0070	*	*	1	針棒	NEEDLE BAR
30	N0119	*	*	1	針 DPX17 (#19)	NEEDLE DPX17 (#19)
31	V0071	*	*	1	ねじ	SCREW
32	V1505	*	*	1	針棒糸掛	NEEDLE BAR THREAD GUIDE
33	V0073	*	*	1	針棒抱き	NEEDLE BAR CONNECTING STUD
34	V0074	*	*	1	針棒固定抱き	NEEDLE BAR HOLDER
35	V0075	*	*	1	針棒固定抱き座	WASHER
36	V0076	*	*	1	ねじ	SCREW
37	V0077	*	*	1	ねじ	SCREW
38	V0078	*	*	1	針棒連結	NEEDLE BAR CONNECTING LINK
39	V0079	*	*	1	ねじ	SCREW
40	V0080	*	*	1	針棒連結案内板	NEEDLE BAR CONNECTING LINK GUIDE PLATE
41	V0081	*	*	1	ねじ	SCREW
42	V0082	*	*	1	ねじ	SCREW
43	V1303	-	*	1	針棒土台振れ止め板	NEEDLE BAR ROCK FRAME GUIDE
44	V1304	-	*	1	ねじ	SCREW

押え棒、押え上げレバー
PRESSER BAR, PRESSER FOOT LIFTING LEVER

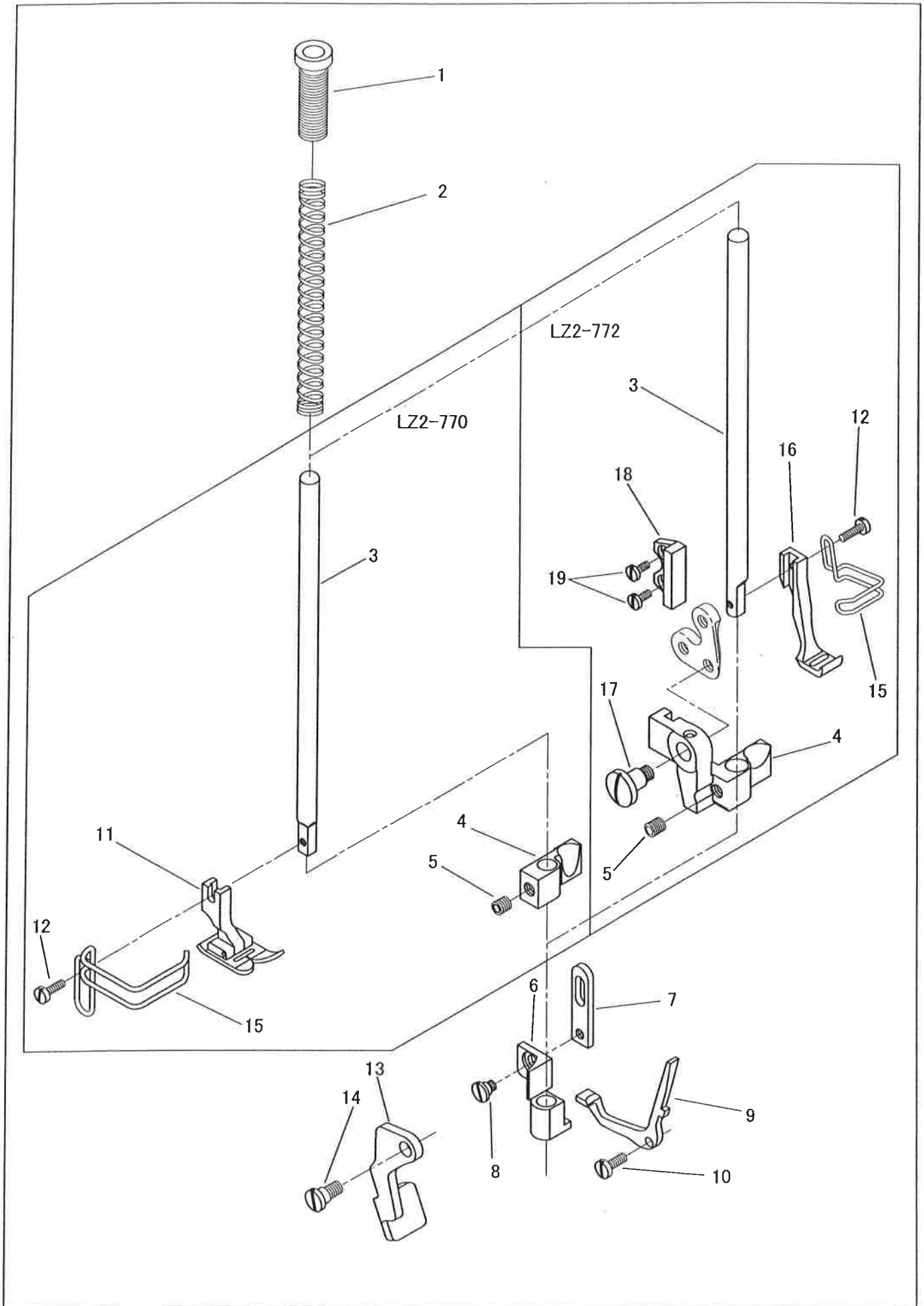

押え棒、押え上げレバー

PRESSER BAR, PRESSER FOOT LIFTING LEVER

No.	部品番号 PARTS NO.	LZ2-770	LZ2-772	個数 QTY	品名	DESCRIPTION
1	V0116	*	*	1	筒ねじ	PRESSER BAR THUMB SCREW
2	V0117	*	*	1	押え棒スプリング	PRESSER BAR SPRING
3	V0118	*	*	1	押え棒	PRESSER BAR
4	V0119	*	-	1	押え棒抱き	PRESSER BAR GUIDE BRACKET
4	V1305	-	*	1	押え棒抱き	PRESSER BAR GUIDE BRACKET
5	V0120	*	*	1	ねじ	SCREW
6	V0121	*	*	1	押え棒通り抱き	PRESSER BAR LIFTING AND RELEASING BRACKET
7	V0122	*	*	1	短冊メガネ	LIFTING LEVER LINK
8	V0123	*	*	1	ねじ	SCREW
9	V0124	*	*	1	皿浮かし	TENSION RELEASING LEVER
10	V0125	*	*	1	ねじ	SCREW
11	V0126	*	-	1	押え金	PRESSER FOOT
12	V0127	*	*	1	ねじ	SCREW
13	41003	*	*	1	押え上げレバー	PRESSER FOOT LIFTING LEVER
14	V0128	*	*	1	ねじ	SCREW
15	V0166	*	*	1	フィンガーガード	FINGER GUARD
16	V1306	-	*	1	中押え	PRESSER FOOT
17	V1307	-	*	1	三つ孔連結止めねじ	HINGE SCREW
18	V1308	-	*	1	押え棒抱き案内	PRESSER BAR GUIDE BRACKET SUPPORT
19	V1309	-	*	2	ねじ	SCREW

針振りカム、針振り調節ダイヤル
ZIGZAG CAM, ZIGZAG ADJUSTING DIAL

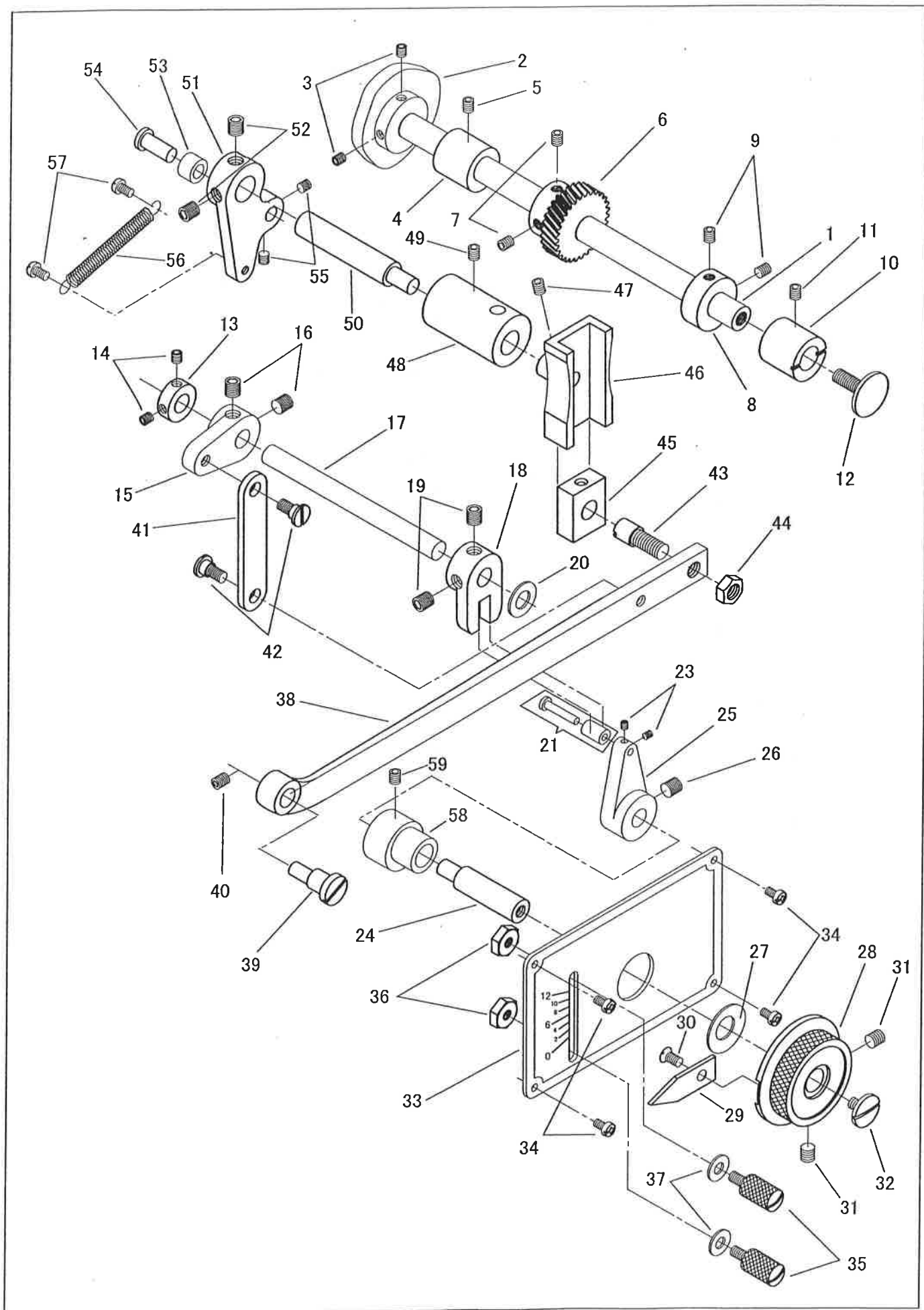

針振りカム、針振り調節ダイヤル
ZIGZAG CAM, ZIGZAG ADJUSTING DIAL

No.	部品番号 PARTS NO.	┌Z2-770	└Z2-772	個数 QTY	品名	DESCRIPTION
1	V0129	*	*	1	針振りギヤー軸	ZIGZAG GEAR SHAFT
2	V1506	*	*	1	針振りカム	ZIGZAG CAM
3	V0131	*	*	2	ねじ	SCREW
4	V0132	*	*	1	針振りギヤー軸メタルB	ZIGZAG GEAR SHAFT BUSHING (B)
5	V0133	*	*	1	ねじ	SCREW
6	V1507	*	*	1	針振り大ギヤー	ZIGZAG GEAR (LARGE)
7	V0135	*	*	2	ねじ	SCREW
8	V0130	*	*	1	針振りギヤー軸カラー	ZIGZAG GEAR SHAFT COLLAR
9	V0131	*	*	2	ねじ	SCREW
10	V0138	*	*	1	針振りギヤー軸メタルA	ZIGZAG GEAR SHAFT BUSHING (A)
11	V0139	*	*	1	ねじ	SCREW
12	V0140	*	*	1	ねじ	SCREW
13	V1508	*	*	1	針振り調節軸カラー	ZIGZAG ADJUSTING SHAFT COLLAR
14	V1509	*	*	2	ねじ	SCREW
15	V1510	*	*	1	針振り調節クランク(A)	ZIGZAG ADJUSTING CRANK (A)
16	V1511	*	*	2	ねじ	SCREW
17	V1512	*	*	1	針振り調節軸	ZIGZAG ADJUSTING SHAFT
18	V1513	*	*	1	針振り調節クランク(B)	ZIGZAG ADJUSTING CRANK (B)
19	V1514	*	*	2	ねじ	SCREW
20	V1515	*	*	1	座金	WASHER
21	V1516C	*	*	1	針振り調節ローラー(組)	ZIGZAG ADJUSTING ROLLER COMPLETE
23	V1518	*	*	2	ねじ	SCREW
24	V0152	*	*	1	針振り調節レバー軸	ZIGZAG ADJUSTING LEVER SHAFT
25	V1519	*	*	1	針振り調節レバー	ZIGZAG ADJUSTING LEVER
26	V1520	*	*	1	ねじ	SCREW
27	V0155	*	*	1	ダイヤル座金	DIAL WASHER
28	V0156	*	*	1	針振り調節ダイヤル	ZIGZAG ADJUSTING DIAL
29	V0157	*	*	1	針振り指針	ZIGZAG INDICATOR
30	V0158	*	*	1	ねじ	SCREW
31	V0159	*	*	2	ねじ	SCREW
32	V0160	*	*	1	ねじ	SCREW
33	V0161	*	*	1	針振り目盛板	ZIGZAG INDICATOR PLATE
34	V0162	*	*	4	ねじ	SCREW
35	V0163	*	*	2	ダイヤルストッパー	DIAL STOPPER
36	V0164	*	*	2	ナット	NUT
37	V0165	*	*	2	座金	WASHER
38	V1521	*	*	1	揺動連結	ZIGZAG CONNECTION
39	V0142	*	*	1	偏心ピン	ECCENTRIC PIN
40	V0143	*	*	1	ねじ	SCREW
41	V1522	*	*	1	針振り調節連結	ZIGZAG ADJUSTING LINK
42	V1523	*	*	2	段ねじ	HINGE SCREW
43	V0147	*	*	1	針振り角駒ねじピン	ZIGZAG STUD
44	V0148	*	*	1	ナット	NUT
45	V0149	*	*	1	針振り角駒	ZIGZAG SLIDE BLOCK
46	V0150	*	*	1	針振り角駒案内	ZIGZAG SLIDE BLOCK GUIDE
47	V0151	*	*	1	ねじ	SCREW
48	V1529	*	*	1	針振りカム連結軸メタル	ZIGZAG CAM CONNECTING LEVER SHAFT BUSHING
49	V1530	*	*	1	ねじ	SCREW
50	V1531	*	*	1	針振りカム連結軸	ZIGZAG CAM CONNECTING LEVER SHAFT
51	V1532	*	*	1	針振りカム連結	ZIGZAG CAM CONNECTING LEVER
52	V1533	*	*	2	ねじ	SCREW
53	V1534	*	*	1	針振りローラー	ZIGZAG CAM CONNECTING ROLLER
54	V1535	*	*	1	針振りローラーピン	ZIGZAG CAM CONNECTING ROLLER PIN
55	V1536	*	*	2	ねじ	SCREW
56	V1537	*	*	1	針振りカム連結ばね	ZIGZAG CAM CONNECTING LEVER SPRING
57	V1538	*	*	2	ねじ	SCREW
58	V0153	*	*	1	針振り軸メタル	BUSHING
59	V0154	*	*	1	ねじ	SCREW

送りカム、送り軸
 FEED CAM, FEED ROCK SHAFT

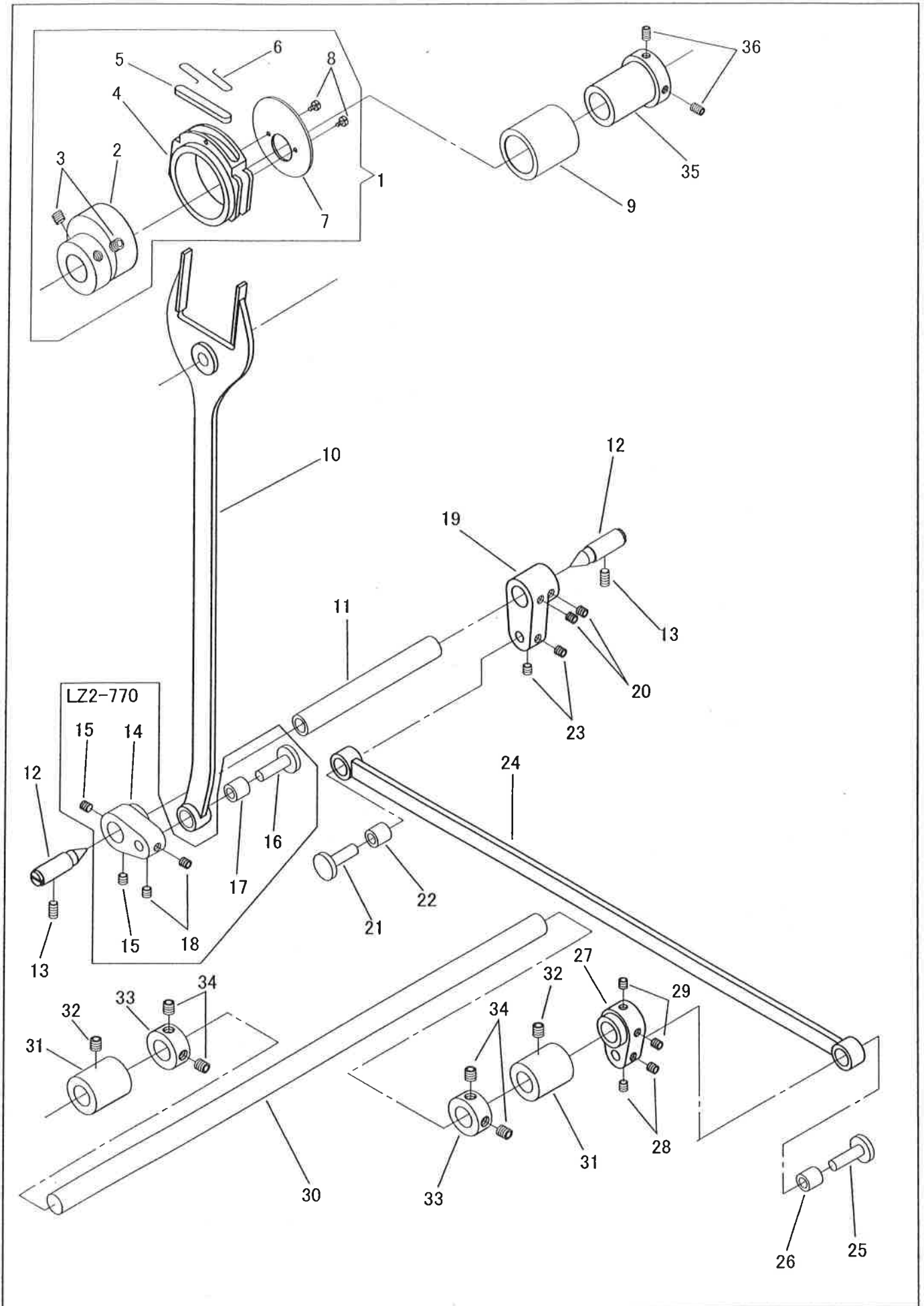

送りカム、送り軸

FEED CAM, FEED ROCK SHAFT

No.	部品番号 PARTS NO.	ZZ-770	ZZ-772	個数 QTY	品名	DESCRIPTION
1	V1014	*	*	1	送りカム(組)	FEED CAM COMPLETE
2	V1015	*	*	1	送りカム	FEED CAM
3	V1016	*	*	2	ねじ	SCREW
4	V1017	*	*	1	送りカムスリーブ	FEED CAM SLEEVE
5	V1018	*	*	1	フェルト	OIL FELT
6	V1019	*	*	1	フェルト押え	OIL FELT STOPPER
7	V1020	*	*	1	送りカムスリーブ押え	FEED CAM SLEEVE RETAINER
8	V1021	*	*	2	ねじ	SCREW
9	V1022	*	*	1	上軸ベアリング	ARM SHAFT BEARING
10	V1023	*	*	1	二又ロッド	FEED FORKED CONNECTION
11	V1024	*	*	1	送り軸(短)	FEED ROCK SHAFT (SHORT)
12	V1025	*	*	2	送り軸(短)センター	FEED ROCK SHAFT (SHORT) CENTER
13	V1026	*	*	2	ねじ	SCREW
14	V1027	*	-	1	送り軸だるま(A)	FEED ROCK SHAFT CRANK (A)
15	V1028	*	-	2	ねじ	SCREW
16	V1029	*	-	1	送り軸だるまピン(A)	FEED ROCK SHAFT CRANK PIN (A)
17	V1030	*	-	1	送り軸だるまベアリング(A)	FEED ROCK SHAFT CRANK BEARING (A)
18	V1031	*	-	2	ねじ	SCREW
19	V1032	*	*	1	送り軸だるま(B)	FEED ROCK SHAFT CRANK (B)
20	V1033	*	*	2	ねじ	SCREW
21	V1034	*	*	1	送り軸だるまピン(B)	FEED ROCK SHAFT CRANK PIN (B)
22	V1035	*	*	1	送り軸だるまベアリング(B)	FEED ROCK SHAFT CRANK BEARING (B)
23	V1036	*	*	2	ねじ	SCREW
24	V1037	*	*	1	送りロッド(長)	FEED ROCK SHAFT CONNECTING LINK (LONG)
25	V1038	*	*	1	送り軸だるまピン(C)	FEED ROCK SHAFT CRANK PIN (C)
26	V1039	*	*	1	送り軸だるまベアリング(C)	FEED ROCK SHAFT CRANK BEARING (C)
27	V1040	*	*	1	送り軸だるま(C)	FEED ROCK SHAFT CRANK (C)
28	V1041	*	*	2	ねじ	SCREW
29	V1042	*	*	2	ねじ	SCREW
30	V1043	*	*	1	送り軸(長)	FEED ROCK SHAFT (LONG)
31	V1044	*	*	2	送り軸メタル	FEED ROCK SHAFT BUSHING
32	V1045	*	*	2	ねじ	SCREW
33	V1046	*	*	2	送り軸カラー	FEED ROCK SHAFT COLLAR
34	V1047	*	*	4	ねじ	SCREW
35	V1132	*	*	1	上軸ベアリングカラー	ARM SHAFT BEARING COLLAR
36	V1133	*	*	2	ねじ	SCREW

タイミングベルト、プーリー
TIMING BELT, PULLEY

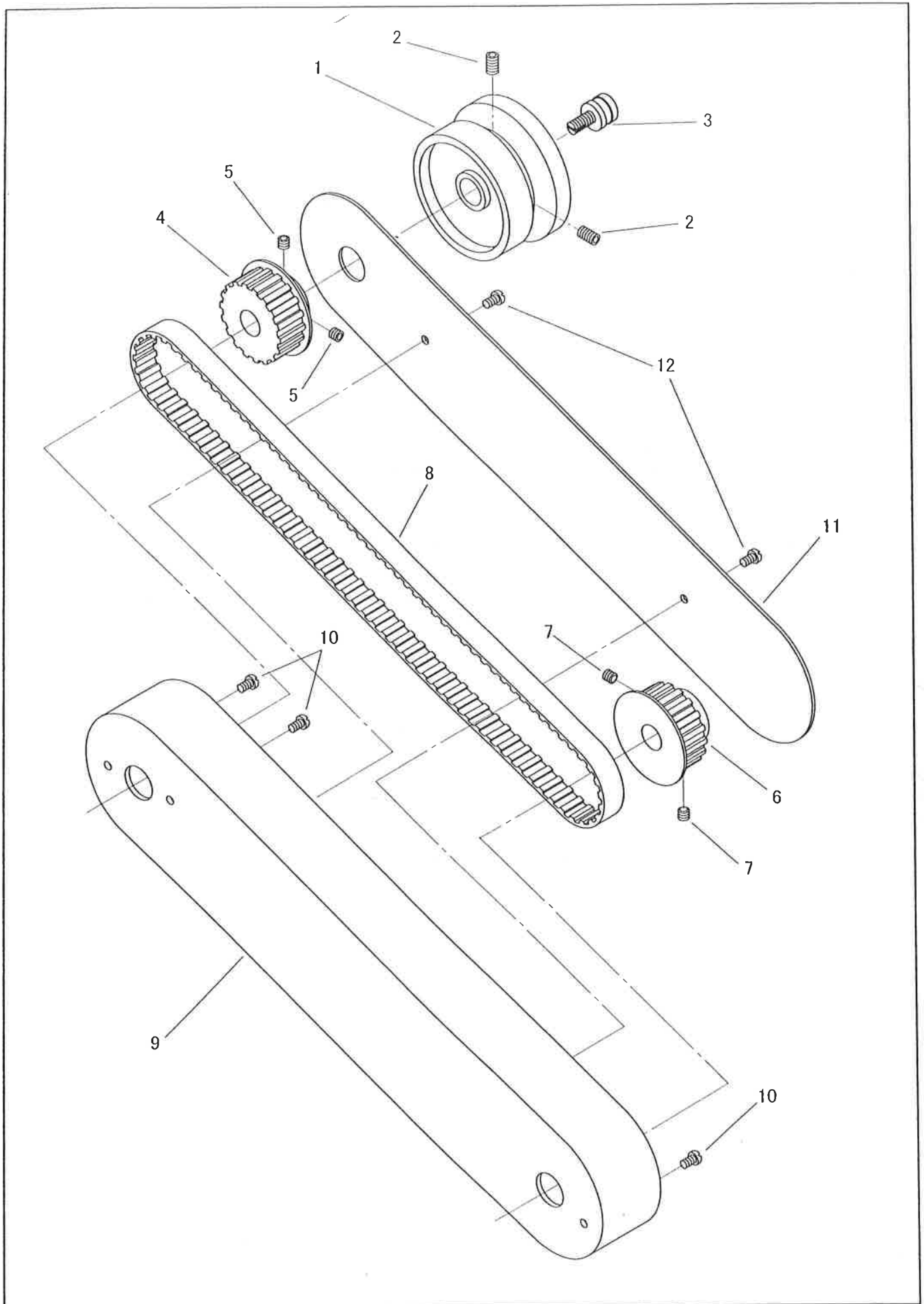

タイミングベルト、プーリー

TIMING BELT, PULLEY

No.	部品番号 PARTS NO.	LZ2-770	LZ2-772	個数 QTY	品名	DESCRIPTION
1	V0043	*	*	1	プーリー	PULLEY
2	V0044	*	*	2	ねじ	SCREW
3	V1773	*	*	1	検出器アダプターねじ	SYNCHRONIZER ADAPTOR SCREW
4	V1048	*	*	1	上ベルトプーリー	ARM SHAFT TIMING PULLEY
5	V1049	*	*	2	ねじ	SCREW
6	V1050	*	*	1	下ベルトプーリー	LOWER SHAFT TIMING PULLEY
7	V1051	*	*	2	ねじ	SCREW
8	V1052	*	*	1	タイミングベルト	TIMING BELT
9	V1053	*	*	1	タイミングベルトカバー(A)	TIMING BELT COVER (A)
10	V1054	*	*	3	ねじ	SCREW
11	V1055	*	*	1	タイミングベルトカバー(B)	TIMING BELT COVER (B)
12	V1056	*	*	2	ねじ	SCREW

下軸、かま
LOWER SHAFT, HOOK

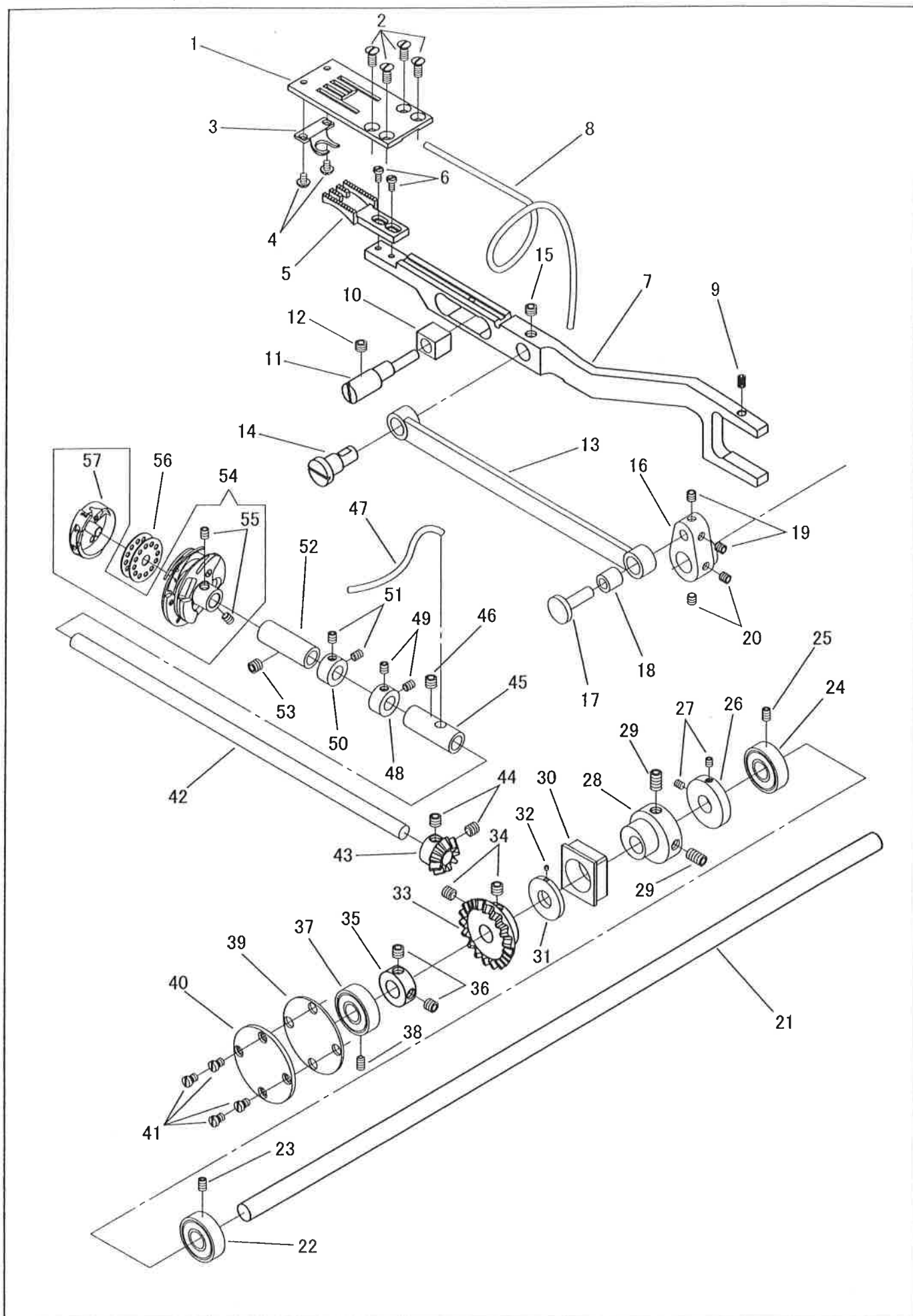

下軸、かま

LOWER SHAFT, HOOK

No.	部品番号	LZ2-770	LZ2-772	個数	品名	DESCRIPTION
	PARTS NO.					
1	V1057	*	*	1	針板	THROAT PLATE
2	V1058	*	*	4	ねじ	SCREW
3	V1059	*	*	1	かま受	HOOK RETAINER
4	V1060	*	*	2	ねじ	SCREW
5	V1061	*	*	1	送り歯	FEED DOG
6	V1062	*	*	2	ねじ	SCREW
7	V1063	*	*	1	送り土台	FEED BAR
8	V1064	*	*	1	油芯(長)	OIL WICK (LONG)
9	V1065	*	*	1	油芯(小)	OIL WICK (SMALL)
10	V1066	*	*	1	送り土台角駒	FEED BAR SLIDE BLOCK
11	V1067	*	*	1	送り土台偏心ピン	FEED BAR ECCENTRIC PIN
12	V1068	*	*	1	ねじ	SCREW
13	V1069	*	*	1	送りロッド(短)	FEED ROCK SHAFT CONNECTING LINK (SHORT)
14	V1070	*	*	1	送り土台ピン	FEED BAR HINGE PIN
15	V1071	*	*	1	ねじ	SCREW
16	V1072	*	*	1	送り軸だるま(D)	FEED ROCK SHAFT CRANK (D)
17	V1073	*	*	1	送り軸だるまピン(D)	FEED ROCK SHAFT CRANK PIN (D)
18	V1074	*	*	1	送り軸だるまベアリング(D)	FEED ROCK SHAFT CRANK BEARING (D)
19	V1075	*	*	2	ねじ	SCREW
20	V1076	*	*	2	ねじ	SCREW
21	V1077	*	*	1	下軸	LOWER SHAFT
22	V1078	*	*	1	下軸ベアリング(後)	LOWER SHAFT BEARING (REAR)
23	V1079	*	*	1	ねじ	SCREW
24	V1080	*	*	1	下軸ベアリング(中間)	LOWER SHAFT BEARING (MIDDLE)
25	V1081	*	*	1	ねじ	SCREW
26	V1082	*	*	1	下軸カラー(後)	LOWER SHAFT COLLAR (REAR)
27	V1083	*	*	2	ねじ	SCREW
28	V1084	*	*	1	上下カム	FEED LIFTING CAM
29	V1085	*	*	2	ねじ	SCREW
30	V1086	*	*	1	上下カムスリーブ	FEED LIFTING CAM SLEEVE
31	V1087	*	*	1	下軸カラー(中間)	LOWER SHAFT COLLAR (MIDDLE)
32	V1088	*	*	1	ねじ	SCREW
33	V1089	*	*	1	下軸ギヤー	LOWER SHAFT GEAR
34	V1090	*	*	2	ねじ	SCREW
35	V1091	*	*	1	下軸カラー(前)	LOWER SHAFT COLLAR (FRONT)
36	V1092	*	*	2	ねじ	SCREW
37	V1093	*	*	1	下軸ベアリング(前)	LOWER SHAFT BEARING (FRONT)
38	V1094	*	*	1	ねじ	SCREW
39	V1095	*	*	1	下軸ベアリングカバーパッキン	LOWER SHAFT BEARING COVER GASKET
40	V1096	*	*	1	下軸ベアリングカバー	LOWER SHAFT BEARING COVER
41	V1097	*	*	4	ねじ	SCREW
42	V1098	*	*	1	かま軸	HOOK SHAFT
43	V1099	*	*	1	かま軸ギヤー	HOOK SHAFT GEAR
44	V1100	*	*	2	ねじ	SCREW
45	V1101	*	*	1	かま軸メタル(A)	HOOK SHAFT BUSHING (A)
46	V1102	*	*	1	ねじ	SCREW
47	V1103	*	*	1	油芯(短)	OIL WICK (SHORT)
48	V1104	*	*	1	かな軸カラー(A)	HOOK SHAFT COLLAR (A)
49	V1105	*	*	2	ねじ	SCREW
50	V1106	*	*	1	かな軸カラー(B)	HOOK SHAFT COLLAR (B)
51	V1107	*	*	2	ねじ	SCREW
52	V1108	*	*	1	かま軸メタル(B)	HOOK SHAFT BUSHING (B)
53	V1109	*	*	1	ねじ	SCREW
54	41011C	*	*	1	かま(組)	ROTATING HOOK COMPLETE
55	41013	*	*	2	ねじ	SCREW
56	V1113	*	*	1	ボビン	BOBBIN
57	41012	*	*	1	ボビンケース	BOBBIN CASE COMPLETE

送り調節、バックレバー
FEED REGULATOR, REVERSE LEVER

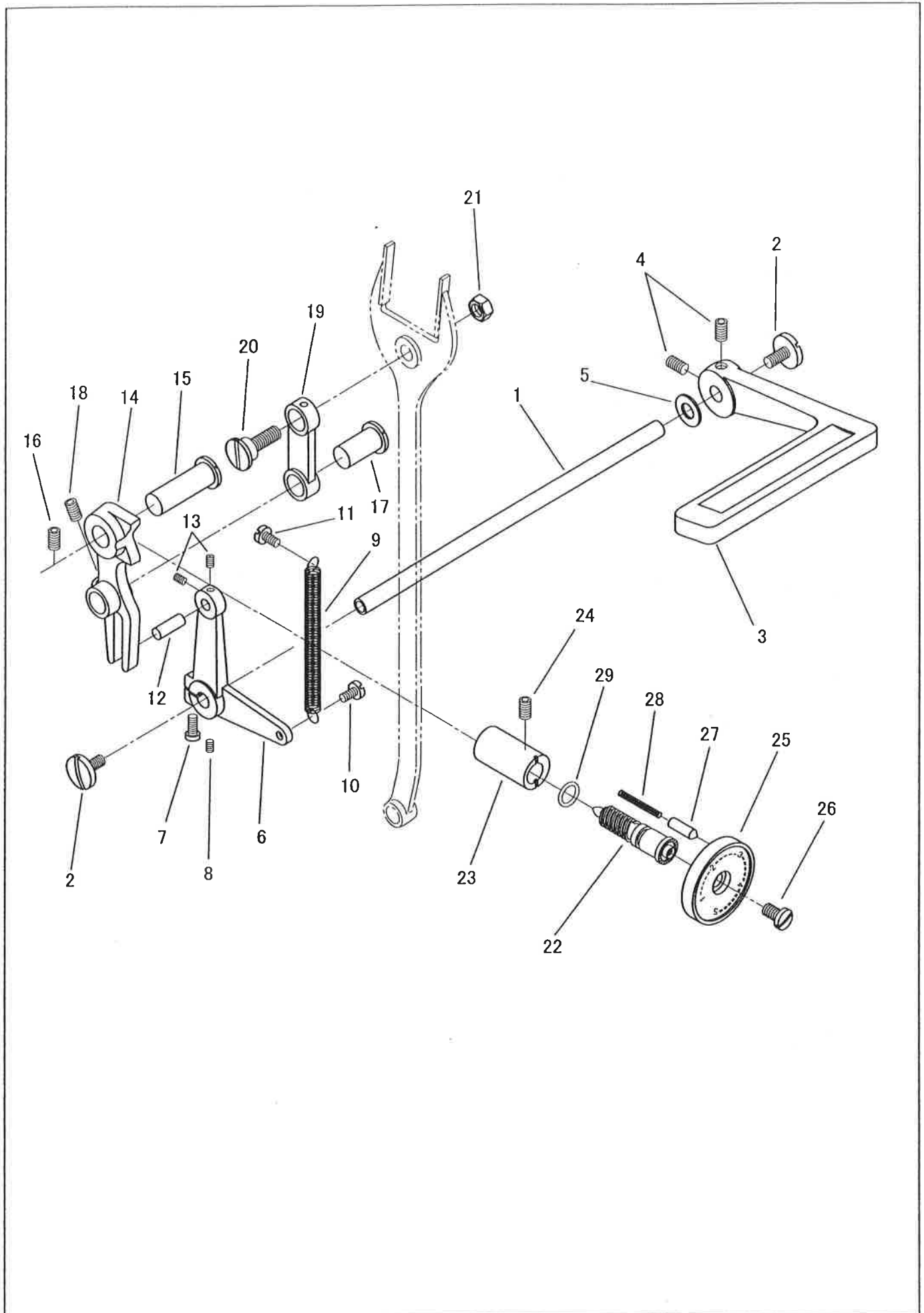

送り調節、バックレバー

FEED REGULATOR, REVERSE LEVER

No.	部品番号 PARTS NO.	LZ2-770	LZ2-772	個数 QTY	品名	DESCRIPTION
1	V0179	*	*	1	バックレバー軸	REVERSE LEVER SHAFT
2	V0180	*	*	2	ねじ	SCREW
3	V0181	*	*	1	バックレバー	REVERSE LEVER
4	V0182	*	*	2	ねじ	SCREW
5	V0183	*	*	1	ワッシャー	WASHER
6	V0184	*	*	1	バックレバー軸だるま	REVERSE LEVER SHAFT CRANK
7	V0185	*	*	1	ねじ	SCREW
8	V0186	*	*	1	ねじ	SCREW
9	V0187	*	*	1	バックレバースプリング	REVERSE LEVER SPRING
10	V0188	*	*	1	ねじ	SCREW
11	V0189	*	*	1	ねじ	SCREW
12	V0190	*	*	1	バックレバー軸だるまピン	REVERSE LEVER SHAFT CRANK PIN
13	V0191	*	*	2	ねじ	SCREW
14	V0192	*	*	1	送り調節	FEED REGULATOR
15	V0193	*	*	1	送り調節ピン	FEED REGULATOR HINGE PIN
16	V0194	*	*	1	ねじ	SCREW
17	V0195	*	*	1	送りリンクピン	FEED CONNECTING LINK HINGE PIN
18	V0196	*	*	1	ねじ	SCREW
19	V0197	*	*	1	送りリンク	FEED CONNECTING LINK
20	V0198	*	*	1	ねじ	SCREW
21	V0199	*	*	1	ナット	NUT
22	39166	*	*	1	送り調節ねじ	FEED ADJUSTING STUD
23	41006	*	*	1	送り調節ねじメタル	FEED ADJUSTING STUD BUSHING
24	V0202	*	*	1	ねじ	SCREW
25	V0203	*	*	1	送り調節ダイヤル	FEED ADJUSTING DIAL
26	12740	*	*	1	ねじ	SCREW 11/64X32 L=8
27	V0205	*	*	1	送り調節ダイヤルピン	PIN
28	V0206	*	*	1	送り調節ダイヤルスプリング	SPRING
29	39167	*	*	1	送り調節ねじOリング	O-RING

大弓
FOOT LIFTER LIFTING LEVER

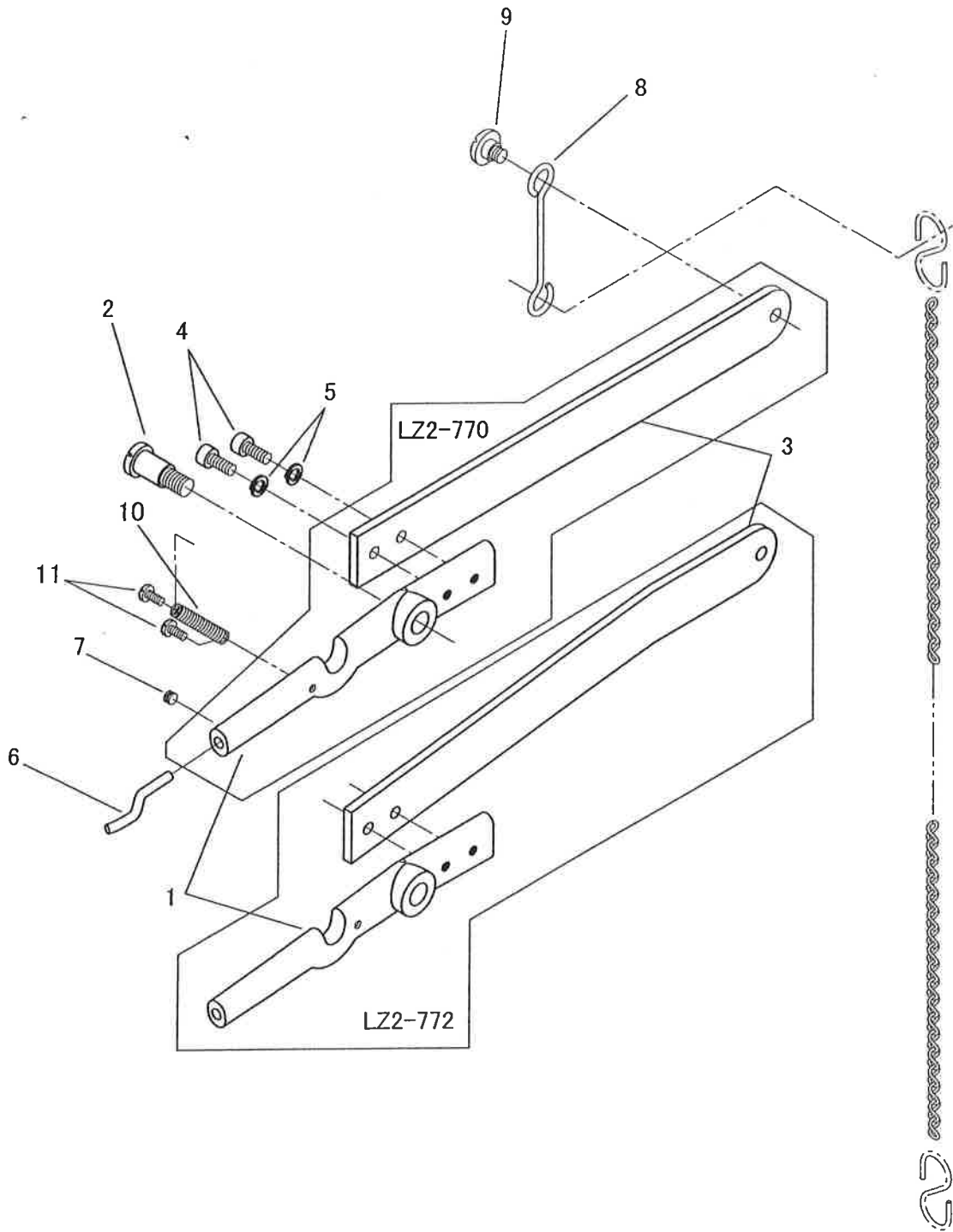

大弓

FOOT LIFTER LIFTING LEVER

No.	部品番号 PARTS NO.	LZ2-770	LZ2-772	個数 QTY	品名	DESCRIPTION
1	V0217	*	-	1	大弓	FOOT LIFTER LIFTING LEVER
1	V1601	-	*	1	大弓	FOOT LIFTER LIFTING LEVER
2	V0218	*	*	1	弓段ねじ	SCREW
3	V1110	*	-	1	小弓	FOOT LIFTER LIFTING LEVER EXTENSION
3	V1602	-	*	1	小弓	FOOT LIFTER LIFTING LEVER EXTENSION
4	V0220	*	*	4	ねじ	SCREW
5	V0221	*	*	4	ワッシャー	WASHER
6	V0222	*	*	1	弓先棒	FOOT LIFTING LEVER PIN
7	V0223	*	*	1	ねじ	SCREW
8	V1111	*	*	1	吊り棒	FOOT LIFTER LIFTING LEVER CONNECTING ROD
9	V1112	*	*	1	ねじ	SCREW
10	V1127	*	*	1	大弓ばね	FOOT LIFTER LIFTING LEVER SPRING
11	V1128	*	*	2	ねじ	SCREW

上送り機構(1)
UPPER FEED MECHANISM (1)

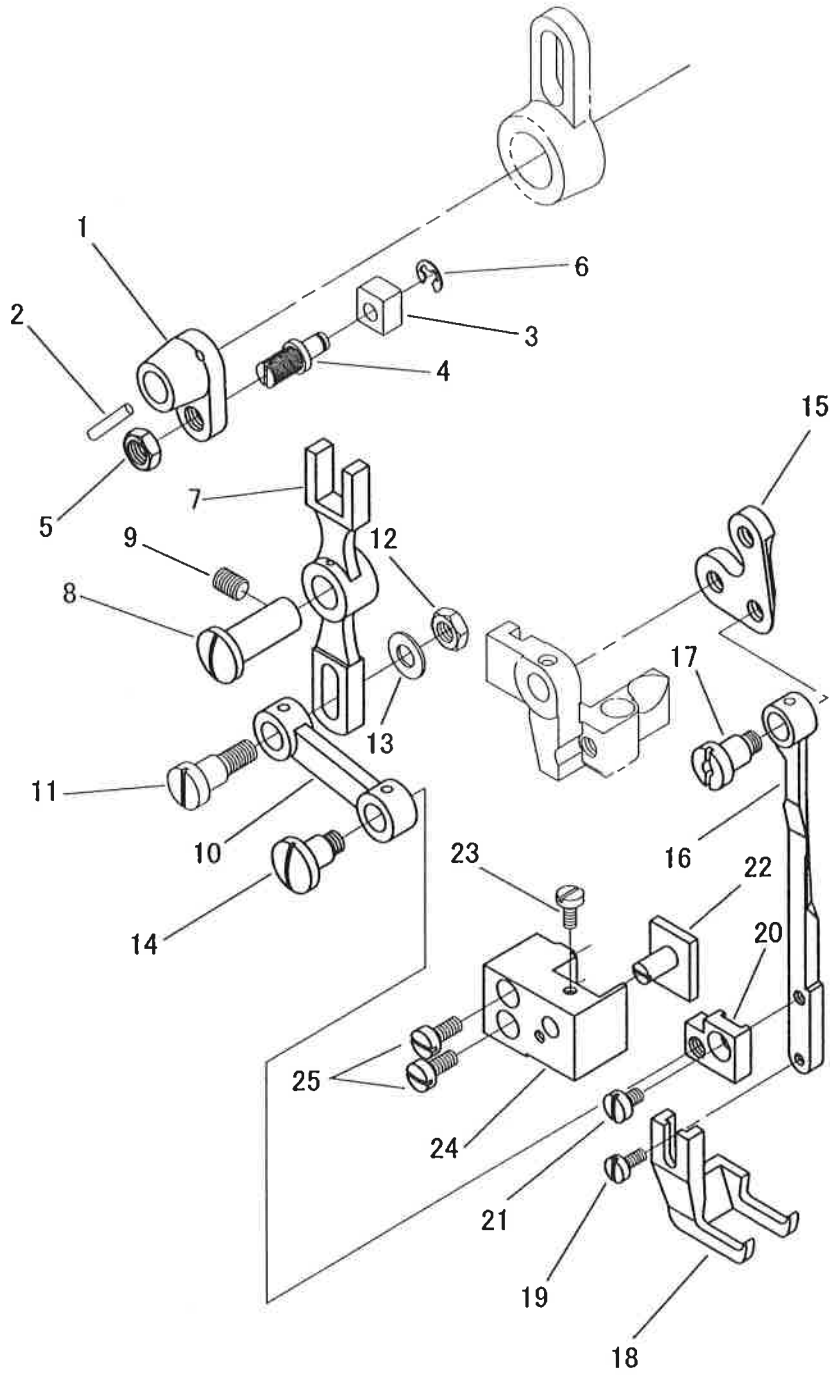

上送り機構(1)

UPPER FEED MECHANISM (1)

No.	部品番号 PARTS NO.	LZ2-770	LZ2-772	個数 QTY	品名	DESCRIPTION
1	V1310	-	*	1	上送り連結	UPPER FEED ROCK SHAFT CRANK
2	V1311	-	*	1	ノックピン	KNOCK-PIN
3	V1312	-	*	1	上送りニ又角玉	UPPER FEED FORKED CONNECTION SLIDE BLOCK
4	V1313	-	*	1	角玉ピンねじ	HINGE SCREW
5	V1314	-	*	1	ナット	NUT
6	V1315	-	*	1	止め輪	RETAINING RING
7	V1316	-	*	1	上送りニ又連結	UPPER FEED FORKED CONNECTION
8	V1317	-	*	1	上送りニ又ピン	HINGE PIN
9	V1318	-	*	1	ねじ	SCREW
10	V1319	-	*	1	上送りリンク	UPPER FEED LEVER LINK
11	V1320	-	*	1	リンク段ねじ	HINGE SCREW
12	V1321	-	*	1	ナット	NUT
13	V1322	-	*	1	ワッシャー	WASHER
14	V1323	-	*	1	リンク段ねじ	HINGE SCREW
15	V1324	-	*	1	三つ孔連結	BELL CRANK
16	V1325	-	*	1	外押え棒	OUTER PRESSER BAR
17	V1326	-	*	1	三つ孔連結止めねじ	HINGE SCREW
18	V1327	-	*	1	外押え	FEED FOOT
19	V1328	-	*	1	ねじ	SCREW
20	V1329	-	*	1	外押え棒連結	OUTER PRESSER BAR CONNECTION
21	V1330	-	*	1	ねじ	SCREW
22	V1331	-	*	1	外押え棒振れ止め	OUTER PRESSER BAR GUIDE
23	V1332	-	*	1	ねじ	SCREW
24	V1333	-	*	1	外押え棒触れ止め固定台	OUTER PRESSER BAR GUIDE BRACKET
25	V1334	-	*	2	ねじ	SCREW

上送り機構(2)

UPPER FEED MECHANISM (2)

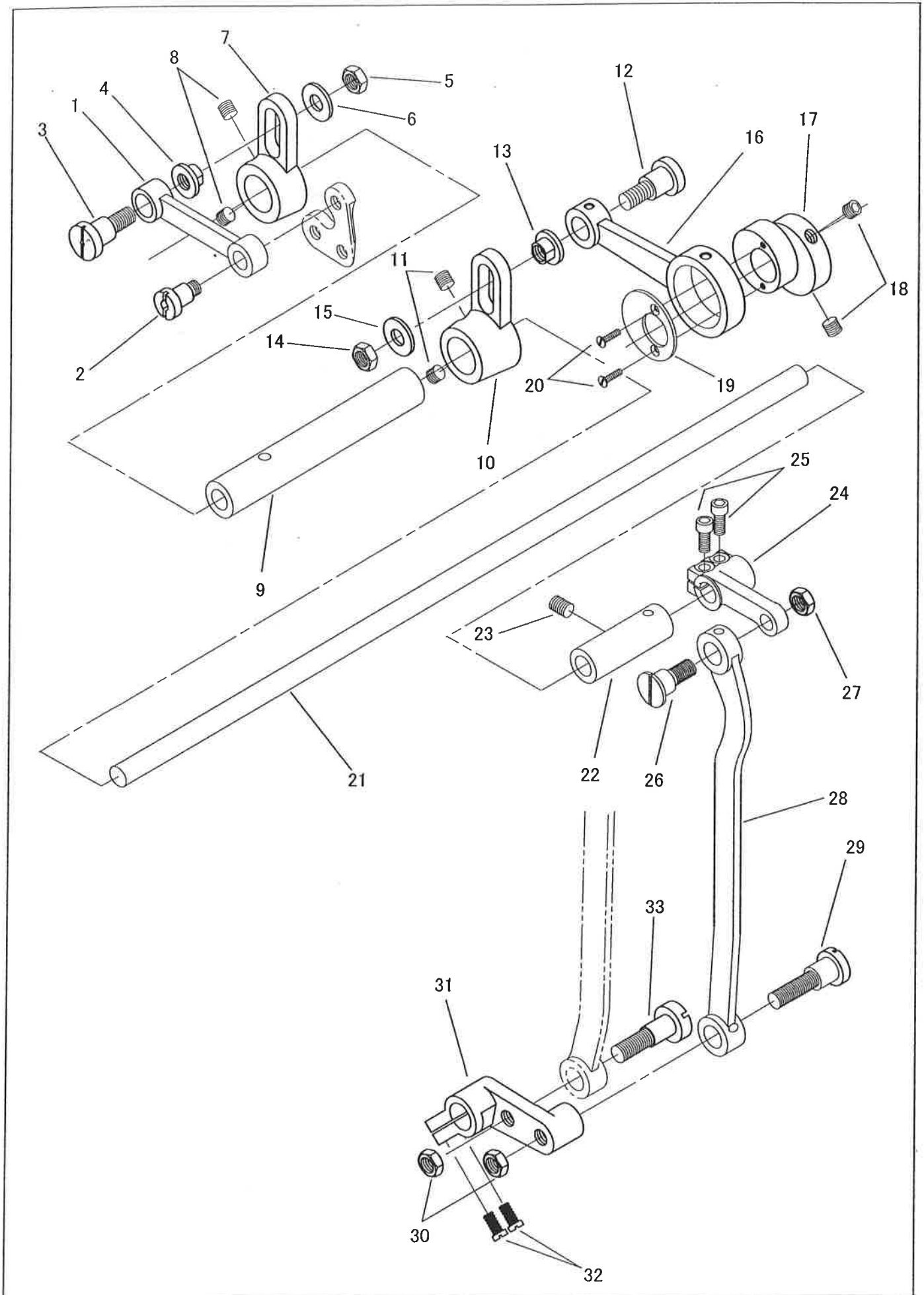

上送り機構(2)

UPPER FEED MECHANISM (2)

No.	部品番号 PARTS NO.	LZ2-770	LZ2-772	個数 QTY	品名	DESCRIPTION
1	V1335	-	*	1	上送りメガネ	BELL CRANK CONNECTING LINK
2	V1336	-	*	1	上送りメガネ段ねじ	HINGE SCREW
3	V1337	-	*	1	上送りメガネ段ねじ	HINGE SCREW
4	V1338	-	*	1	スライドピン	SLIDE PIN
5	V1339	-	*	1	ナット	NUT
6	V1340	-	*	1	ワッシャー	WASHER
7	V1341	-	*	1	横軸だるま(左)	BELL CRANK DRIVING ARM (LEFT)
8	V1342	-	*	2	ねじ	SCREW
9	V1343	-	*	1	横軸	BELL CRANK DRIVING SHAFT
10	V1344	-	*	1	横軸だるま(右)	BELL CRANK DRIVING ARM (RIGHT)
11	V1345	-	*	2	ねじ	SCREW
12	V1346	-	*	1	上送りロッド段ねじ	HINGE SCREW
13	V1347	-	*	1	スライドピン	SLIDE PIN
14	V1348	-	*	1	ナット	NUT
15	V1349	-	*	1	ワッシャー	WASHER
16	V1350	-	*	1	上送りロッド	UPPER FEED ECCENTRIC CONNECTION
17	V1351	-	*	1	上送りカム	UPPER FEED ECCENTRIC
18	V1352	-	*	2	ねじ	SCREW
19	V1353	-	*	1	上送りロッド押え	UPPER FEED ECCENTRIC RETAINER
20	V1354	-	*	2	ねじ	SCREW
21	V1355	-	*	1	上送り軸	UPPER FEED ROCK SHAFT
22	V1356	-	*	1	上送り軸メタル	UPPER FEED ROCK SHAFT BUSHING
23	V1357	-	*	1	ねじ	SCREW
24	V1358	-	*	1	上送り軸連結	UPPER FEED ROCK SHAFT CRANK
25	V1359	-	*	2	ねじ	SCREW
26	V1360	-	*	1	上送り立ロッド段ねじ(上)	HINGE SCREW
27	V1361	-	*	1	ナット	NUT
28	V1362	-	*	1	上送り立ロッド	UPPER FEED ROCK SHAFT CONNECTING ROD
29	V1363	-	*	1	上送り立ロッド段ねじ(下)	HINGE SCREW
30	V1364	-	*	2	ナット	NUT
31	V1365	-	*	1	送り軸だるま	FEED ROCK SHAFT CRANK
32	V1366	-	*	2	ねじ	SCREW
33	V1603	-	*	1	ねじ	SCREW

付属品1
ACCESSORIES 1

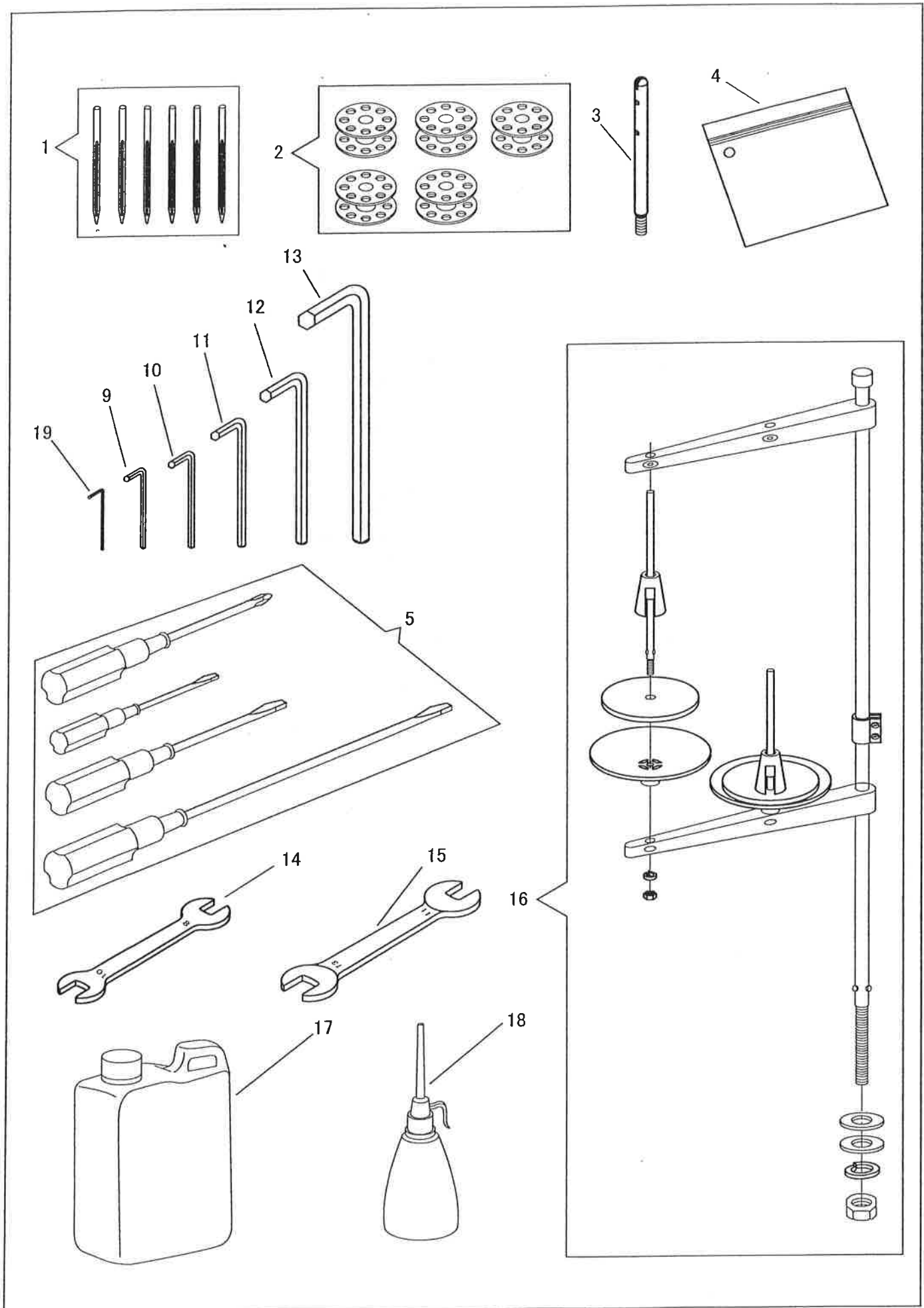

付属品1

ACCESSORIES 1

No.	部品番号 PARTS NO.	LZ2-770	LZ2-772	個数 QTY	品名	DESCRIPTION
1	N0119	*	*	6	針 DPX17 (#19)	NEEDLE DPX17 (#19)
2	V1113	*	*	5	ボビン	BOBBIN
3	V0231	*	*	1	糸立棒	ARM SPOOL PIN SCREW
4	8132-A	*	*	1	部品袋	ACCESSORY BAG
5	25649C	*	*	1	ドライバー4点組	SCREW DRIVER COMPLETE
9	V0232	*	*	1	六角レンチ(2 mm)	HEXAGONAL WRENCH (2 mm)
10	V0233	*	*	1	六角レンチ (2.5 mm)	HEXAGONAL WRENCH (2.5 mm)
11	V0234	*	*	1	六角レンチ (3 mm)	HEXAGONAL WRENCH (3 mm)
12	V0235	*	*	1	六角レンチ(4 mm)	HEXAGONAL WRENCH (4 mm)
13	V1114	*	*	1	六角レンチ(6 mm)	HEXAGONAL WRENCH (6 mm)
14	V0236	*	*	1	スパナ(10X8)	SPANNER (10X8)
15	V1115	*	*	1	スパナ(13X11)	SPANNER (13X11)
16	35254	*	*	1	糸立セット	THREAD STAND COMPLETE
17	11193	*	*	1	オイルタンク	OIL TANK
18	8125	*	*	1	油差し	OILER
19	V1131	*	*	1	六角レンチ(0.89 mm)	HEXAGONAL WRENCH (0.89 mm)

付属品2
ACCESSORIES 2

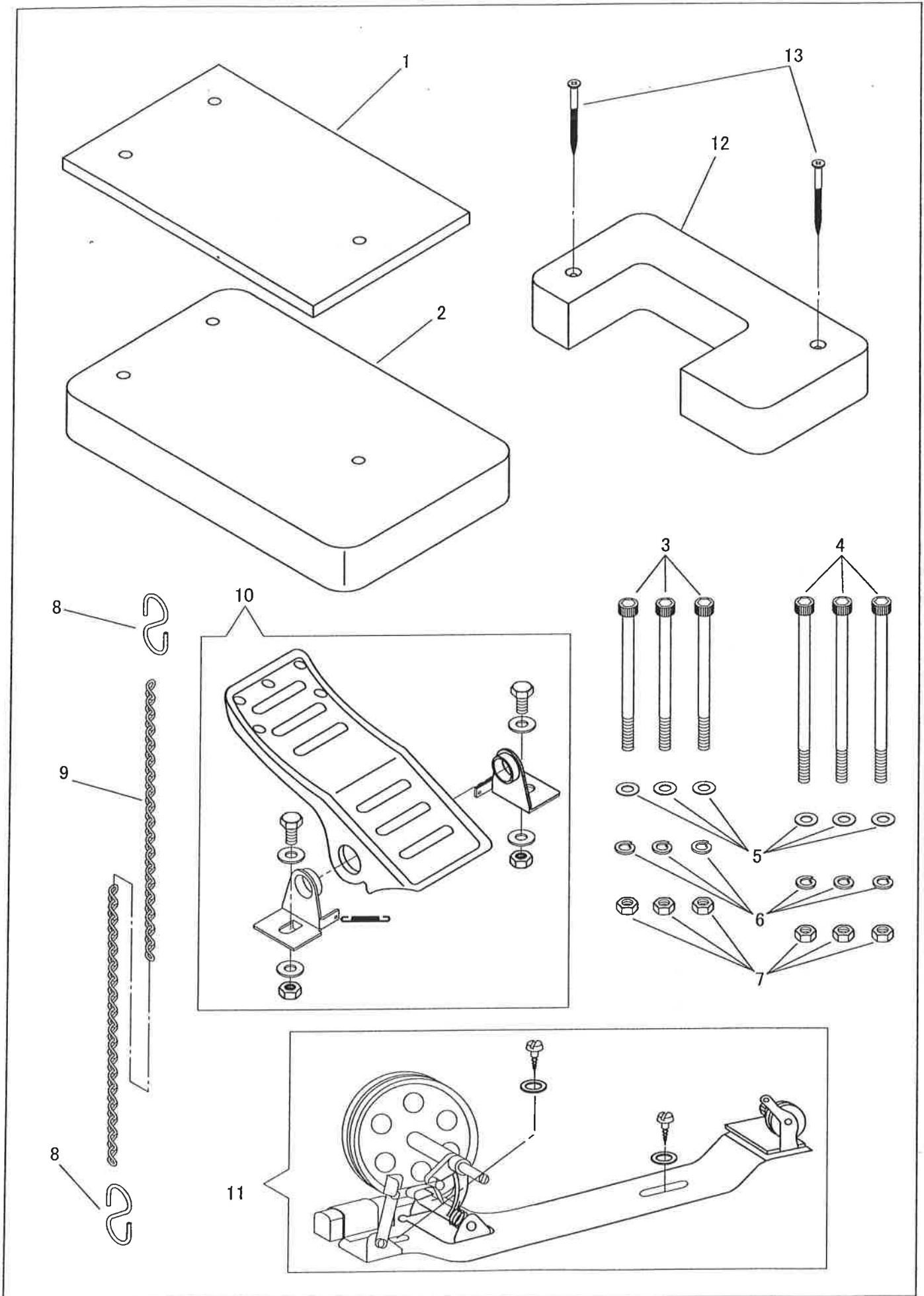

付属品2

ACCESSORIES 2

No.	部品番号 PARTS NO.	LZ2-770	LZ2-772	個数 QTY	品名	DESCRIPTION
1	V1116	*	*	1	頭部受フェルト	OIL ABSORPTION FELT
2	V1117	*	*	1	補助テーブル	AUXILIARY BOARD
3	V1118	*	*	3	頭部止ねじ(短)	BOLT (SHORT)
4	V1119	*	*	3	頭部止ねじ(長)	BOLT (LONG)
5	V1120	*	*	6	頭部止ねじワッシャー	PLAIN WASHER
6	V1121	*	*	6	頭部止ねじスプリングワッシャー	SPRING WASHER
7	V1122	*	*	6	頭部止ねじナット	NUT
8	V1123	*	*	2	くさりフック	S-HOOK
9	V1124	*	*	1	くさり 900 mm	CHAIN 900 mm
10	V1125	*	*	1	ペダルセット	PEDAL COMPLETE
11	41017	*	*	1	糸巻きセット	BOBBIN WINDER COMPLETE
12	V1129	*	*	1	補助テーブル(ベルトガード用)	AUXILIARY BOARD FOR BELT GUARD
13	V1130	*	*	2	十字穴付木ねじ(皿木ねじ)	CROSS-RECESSED HEAD WOOD SCREW (FLAT COUNTERSUNK HEAD) 5.1X(L=63) mm

SEIKO SEWING MACHINE CO., LTD.

2-13-6 Sakaecho, Funabashi-shi Chiba Prefecture,
273-0018, Japan

TEL: 81-47-420-3561 (Overseas dept.)

FAX: 81-47-420-3560

E-mail: export@seiko-sewing.co.jp

<http://www.seiko-sewing.co.jp/>

セイコーミシン株式会社

〒273-0018 千葉県船橋市栄町2-13-6

TEL: 047-420-3561, IP電話: 050-3535-3491

FAX: 047-420-3560

E-mail: eigyos@seiko-sewing.co.jp

(国内営業)

Parts No. PB89330 (1016)

Rev.1.1