

送りカム、送り軸
FEED CAM, FEED ROCK SHAFT

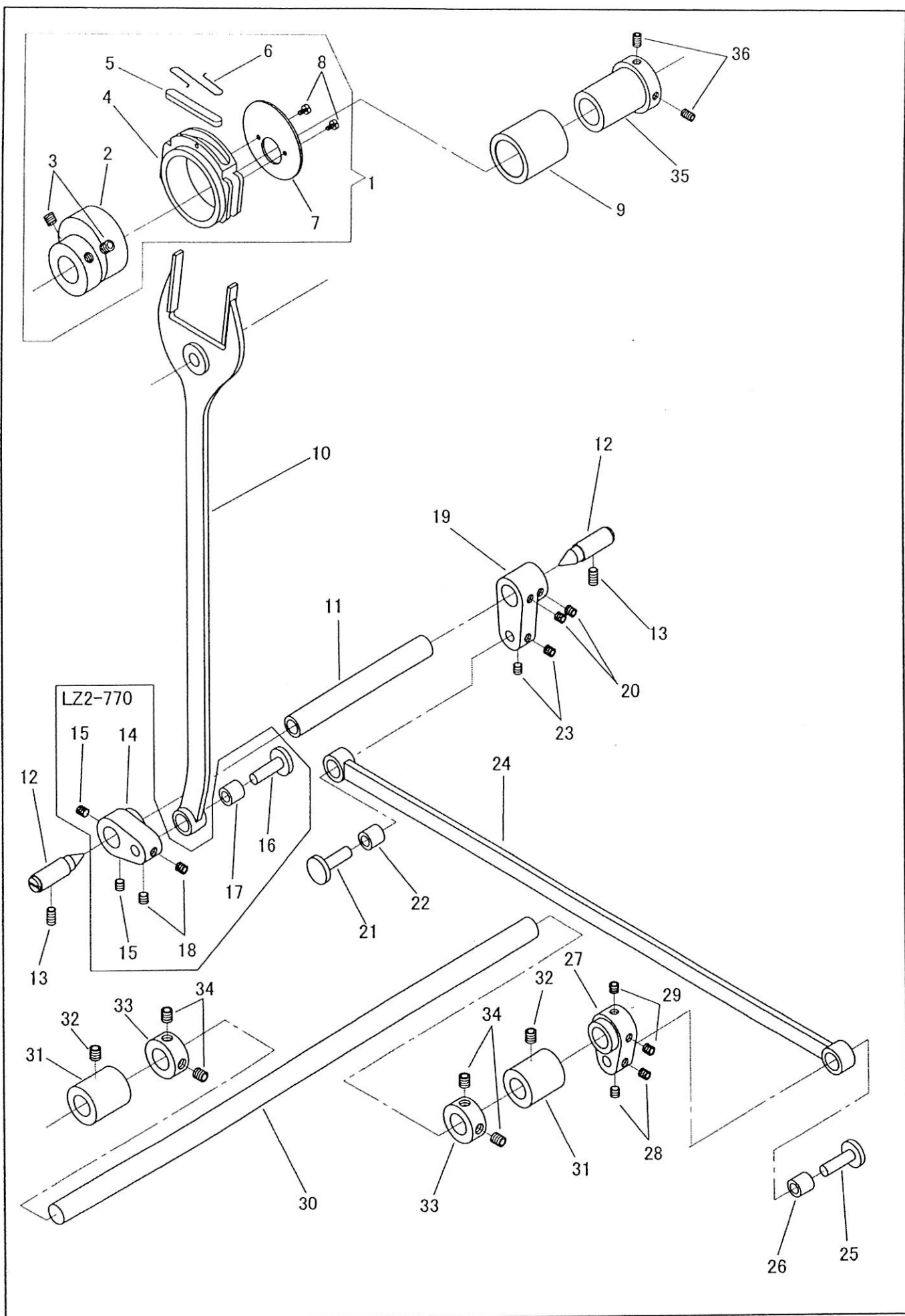

送りカム、送り軸

FEED CAM, FEED ROCK SHAFT

No.	部品番号	LZ2-770	LZ2-772	個数 QTY	品名	DESCRIPTION
	PARTS NO.					
1	V1014	*	*	1	送りカム(組)	FEED CAM COMPLETE
2	V1015	*	*	1	送りカム	FEED CAM
3	V1016	*	*	2	ねじ	SCREW
4	V1017	*	*	1	送りカムスリーブ	FEED CAM SLEEVE
5	V1018	*	*	1	フェルト	OIL FELT
6	V1019	*	*	1	フェルト押え	OIL FELT STOPPER
7	V1020	*	*	1	送りカムスリーブ押え	FEED CAM SLEEVE RETAINER
8	V1021	*	*	2	ねじ	SCREW
9	V1022	*	*	1	上軸ベアリング	ARM SHAFT BEARING
10	V1023	*	*	1	二又ロッド	FEED FORKED CONNECTION
11	V1024	*	*	1	送り軸(短)	FEED ROCK SHAFT (SHORT)
12	V1025	*	*	2	送り軸(短)センター	FEED ROCK SHAFT (SHORT) CENTER
13	V1026	*	*	2	ねじ	SCREW
14	V1027	*	-	1	送り軸だるま(A)	FEED ROCK SHAFT CRANK (A)
15	V1028	*	-	2	ねじ	SCREW
16	V1029	*	-	1	送り軸だるまピン(A)	FEED ROCK SHAFT CRANK PIN (A)
17	V1030	*	-	1	送り軸だるまベアリング(A)	FEED ROCK SHAFT CRANK BEARING (A)
18	V1031	*	-	2	ねじ	SCREW
19	V1032	*	*	1	送り軸だるま(B)	FEED ROCK SHAFT CRANK (B)
20	V1033	*	*	2	ねじ	SCREW
21	V1034	*	*	1	送り軸だるまピン(B)	FEED ROCK SHAFT CRANK PIN (B)
22	V1035	*	*	1	送り軸だるまベアリング(B)	FEED ROCK SHAFT CRANK BEARING (B)
23	V1036	*	*	2	ねじ	SCREW
24	V1037	*	*	1	送りロッド(長)	FEED ROCK SHAFT CONNECTING LINK (LONG)
25	V1038	*	*	1	送り軸だるまピン(C)	FEED ROCK SHAFT CRANK PIN (C)
26	V1039	*	*	1	送り軸だるまベアリング(C)	FEED ROCK SHAFT CRANK BEARING (C)
27	V1040	*	*	1	送り軸だるま(C)	FEED ROCK SHAFT CRANK (C)
28	V1041	*	*	2	ねじ	SCREW
29	V1042	*	*	2	ねじ	SCREW
30	V1043	*	*	1	送り軸(長)	FEED ROCK SHAFT (LONG)
31	V1044	*	*	2	送り軸メタル	FEED ROCK SHAFT BUSHING
32	V1045	*	*	2	ねじ	SCREW
33	V1046	*	*	2	送り軸カラー	FEED ROCK SHAFT COLLAR
34	V1047	*	*	4	ねじ	SCREW
35	V1132	*	*	1	上軸ベアリングカラー	ARM SHAFT BEARING COLLAR
36	V1133	*	*	2	ねじ	SCREW

タイミングベルト、プーリー
TIMING BELT, PULLEY

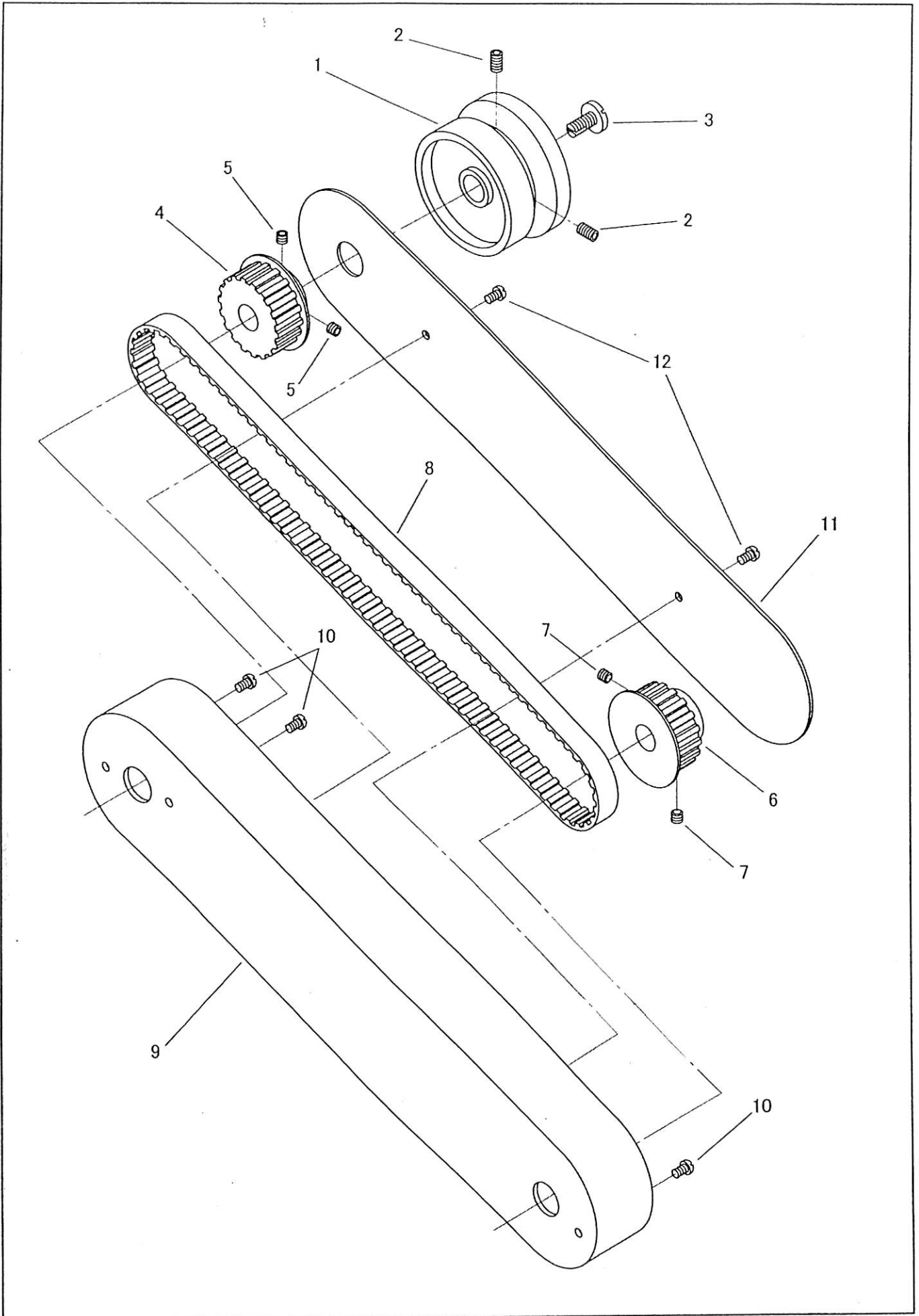

タイミングベルト、プーリー

TIMING BELT, PULLEY

No.	部品番号 PARTS NO.	LZ2-770	LZ2-772	個数 QTY	品名	DESCRIPTION
1	V0043	*	*	1	プーリー	PULLEY
2	V0044	*	*	2	ねじ	SCREW
3	V0045	*	*	1	ねじ	SCREW
4	V1048	*	*	1	上ベルトプーリー	ARM SHAFT TIMING PULLEY
5	V1049	*	*	2	ねじ	SCREW
6	V1050	*	*	1	下ベルトプーリー	LOWER SHAFT TIMING PULLEY
7	V1051	*	*	2	ねじ	SCREW
8	V1052	*	*	1	タイミングベルト	TIMING BELT
9	V1053	*	*	1	タイミングベルトカバー(A)	TIMING BELT COVER (A)
10	V1054	*	*	3	ねじ	SCREW
11	V1055	*	*	1	タイミングベルトカバー(B)	TIMING BELT COVER (B)
12	V1056	*	*	2	ねじ	SCREW

下軸、かま

LOWER SHAFT, HOOK

No.	部品番号 PARTS NO.	LZ2-770	LZ2-772	個数 QTY	品名	DESCRIPTION
1	V1057	*	*	1	針板	THROAT PLATE
2	V1058	*	*	4	ねじ	SCREW
3	V1059	*	*	1	かま受	HOOK RETAINER
4	V1060	*	*	2	ねじ	SCREW
5	V1061	*	*	1	送り歯	FEED DOG
6	V1062	*	*	2	ねじ	SCREW
7	V1063	*	*	1	送り土台	FEED BAR
8	V1064	*	*	1	油芯(長)	OIL WICK (LONG)
9	V1065	*	*	1	油芯(小)	OIL WICK (SMALL)
10	V1066	*	*	1	送り土台角駒	FEED BAR SLIDE BLOCK
11	V1067	*	*	1	送り土台偏心ピン	FEED BAR ECCENTRIC PIN
12	V1068	*	*	1	ねじ	SCREW
13	V1069	*	*	1	送りロッド(短)	FEED ROCK SHAFT CONNECTING LINK (SHORT)
14	V1070	*	*	1	送り土台ピン	FEED BAR HINGE PIN
15	V1071	*	*	1	ねじ	SCREW
16	V1072	*	*	1	送り軸だるま(D)	FEED ROCK SHAFT CRANK (D)
17	V1073	*	*	1	送り軸だるまピン(D)	FEED ROCK SHAFT CRANK PIN (D)
18	V1074	*	*	1	送り軸だるまベアリング(D)	FEED ROCK SHAFT CRANK BEARING (D)
19	V1075	*	*	2	ねじ	SCREW
20	V1076	*	*	2	ねじ	SCREW
21	V1077	*	*	1	下軸	LOWER SHAFT
22	V1078	*	*	1	下軸ベアリング(後)	LOWER SHAFT BEARING (REAR)
23	V1079	*	*	1	ねじ	SCREW
24	V1080	*	*	1	下軸ベアリング(中間)	LOWER SHAFT BEARING (MIDDLE)
25	V1081	*	*	1	ねじ	SCREW
26	V1082	*	*	1	下軸カラー(後)	LOWER SHAFT COLLAR (REAR)
27	V1083	*	*	2	ねじ	SCREW
28	V1084	*	*	1	上下カム	FEED LIFTING CAM
29	V1085	*	*	2	ねじ	SCREW
30	V1086	*	*	1	上下カムスリーブ	FEED LIFTING CAM SLEEVE
31	V1087	*	*	1	下軸カラー(中間)	LOWER SHAFT COLLAR (MIDDLE)
32	V1088	*	*	1	ねじ	SCREW
33	V1089	*	*	1	下軸ギヤー	LOWER SHAFT GEAR
34	V1090	*	*	2	ねじ	SCREW
35	V1091	*	*	1	下軸カラー(前)	LOWER SHAFT COLLAR (FRONT)
36	V1092	*	*	2	ねじ	SCREW
37	V1093	*	*	1	下軸ベアリング(前)	LOWER SHAFT BEARING (FRONT)
38	V1094	*	*	1	ねじ	SCREW
39	V1095	*	*	1	下軸ベアリングカバーパッキン	LOWER SHAFT BEARING COVER GASKET
40	V1096	*	*	1	下軸ベアリングカバー	LOWER SHAFT BEARING COVER
41	V1097	*	*	4	ねじ	SCREW
42	V1098	*	*	1	かま軸	HOOK SHAFT
43	V1099	*	*	1	かま軸ギヤー	HOOK SHAFT GEAR
44	V1100	*	*	2	ねじ	SCREW
45	V1101	*	*	1	かま軸メタル(A)	HOOK SHAFT BUSHING (A)
46	V1102	*	*	1	ねじ	SCREW
47	V1103	*	*	1	油芯(短)	OIL WICK (SHORT)
48	V1104	*	*	1	かな軸カラー(A)	HOOK SHAFT COLLAR (A)
49	V1105	*	*	2	ねじ	SCREW
50	V1106	*	*	1	かな軸カラー(B)	HOOK SHAFT COLLAR (B)
51	V1107	*	*	2	ねじ	SCREW
52	V1108	*	*	1	かま軸メタル(B)	HOOK SHAFT BUSHING (B)
53	V1109	*	*	1	ねじ	SCREW
54	41011C	*	*	1	かま(組)	ROTATING HOOK COMPLETE
55	41013	*	*	2	ねじ	SCREW
56	V1113	*	*	1	ボビン	BOBBIN
57	41012	*	*	1	ボビンケース	BOBBIN CASE COMPLETE

送り調節、バックレバー
FEED REGULATOR, REVERSE LEVER

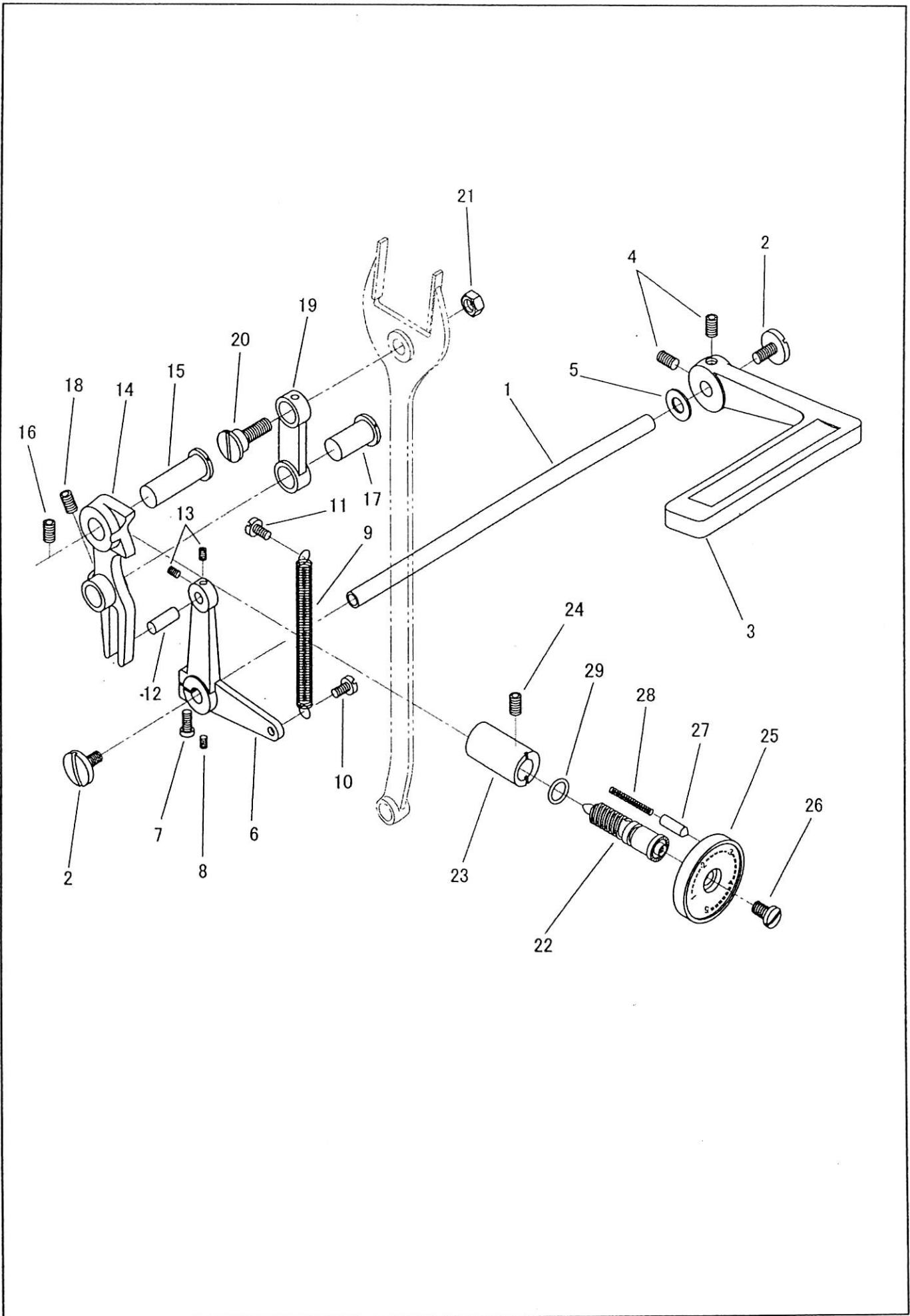

送り調節、バックレバー

FEED REGULATOR, REVERSE LEVER

No.	部品番号 PARTS NO.	LZ2-770	LZ2-772	個数 QTY	品名	DESCRIPTION
1	V0179	*	*	1	バックレバー軸	REVERSE LEVER SHAFT
2	V0180	*	*	2	ねじ	SCREW
3	V0181	*	*	1	バックレバー	REVERSE LEVER
4	V0182	*	*	2	ねじ	SCREW
5	V0183	*	*	1	ワッシャー	WASHER
6	V0184	*	*	1	バックレバー軸だるま	REVERSE LEVER SHAFT CRANK
7	V0185	*	*	1	ねじ	SCREW
8	V0186	*	*	1	ねじ	SCREW
9	V0187	*	*	1	バックレバースプリング	REVERSE LEVER SPRING
10	V0188	*	*	1	ねじ	SCREW
11	V0189	*	*	1	ねじ	SCREW
12	V0190	*	*	1	バックレバー軸だるまピン	REVERSE LEVER SHAFT CRANK PIN
13	V0191	*	*	2	ねじ	SCREW
14	V0192	*	*	1	送り調節	FEED REGULATOR
15	V0193	*	*	1	送り調節ピン	FEED REGULATOR HINGE PIN
16	V0194	*	*	1	ねじ	SCREW
17	V0195	*	*	1	送りリンクピン	FEED CONNECTING LINK HINGE PIN
18	V0196	*	*	1	ねじ	SCREW
19	V0197	*	*	1	送りリンク	FEED CONNECTING LINK
20	V0198	*	*	1	ねじ	SCREW
21	V0199	*	*	1	ナット	NUT
22	41010	*	*	1	送り調節ねじ	FEED ADJUSTING STUD
23	41006	*	*	1	送り調節ねじメタル	FEED ADJUSTING STUD BUSHING
24	V0202	*	*	1	ねじ	SCREW
25	V0203	*	*	1	送り調節ダイヤル	FEED ADJUSTING DIAL
26	12740	*	*	1	ねじ	SCREW 11/64X32 L=8
27	V0205	*	*	1	送り調節ダイヤルピン	PIN
28	V0206	*	*	1	送り調節ダイヤルスプリング	SPRING
29	39167	*	*	1	送り調節ねじOリング	O-RING

大弓
FOOT LIFTER LIFTING LEVER

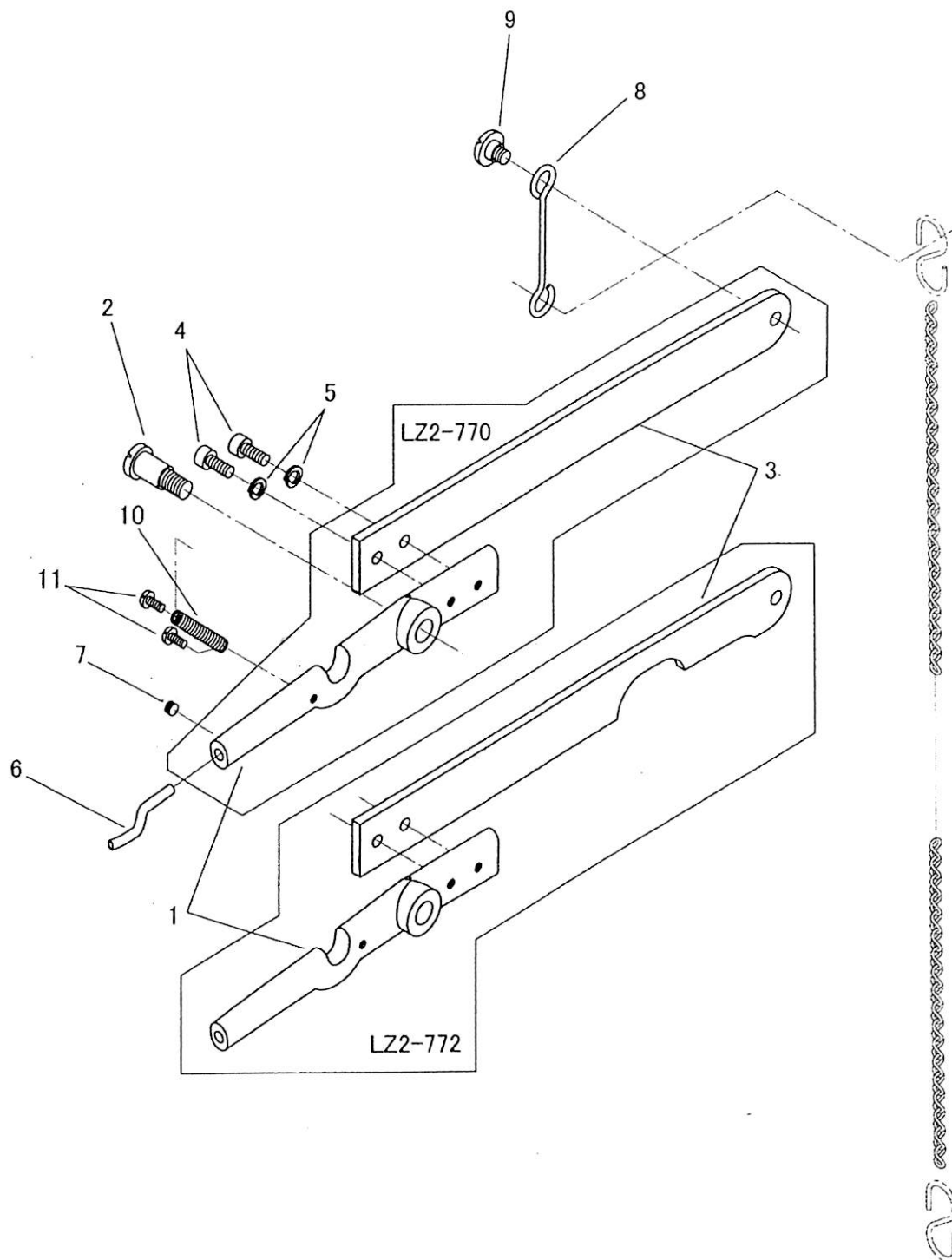

大弓

FOOT LIFTER LIFTING LEVER

No.	部品番号 PARTS NO.	LZ2-770	LZ2-772	個数 QTY	品名	DESCRIPTION
1	V0217	*	-	1	大弓	FOOT LIFTER LIFTING LEVER
1	V1601	-	*	1	大弓	FOOT LIFTER LIFTING LEVER
2	V0218	*	*	1	弓段ねじ	SCREW
3	V1110	*	-	1	小弓	FOOT LIFTER LIFTING LEVER EXTENSION
3	V1602	-	*	1	小弓	FOOT LIFTER LIFTING LEVER EXTENSION
4	V0220	*	*	4	ねじ	SCREW
5	V0221	*	*	4	ワッシャー	WASHER
6	V0222	*	*	1	弓先棒	FOOT LIFTING LEVER PIN
7	V0223	*	*	1	ねじ	SCREW
8	V1111	*	*	1	吊り棒	FOOT LIFTER LIFTING LEVER CONNECTING ROD
9	V1112	*	*	1	ねじ	SCREW
10	V1127	*	*	1	大弓ばね	FOOT LIFTER LIFTING LEVER SPRING
11	V1128	*	*	2	ねじ	SCREW