

SEIKO

PARTS LIST パーツリスト

P W - 6 B - 1

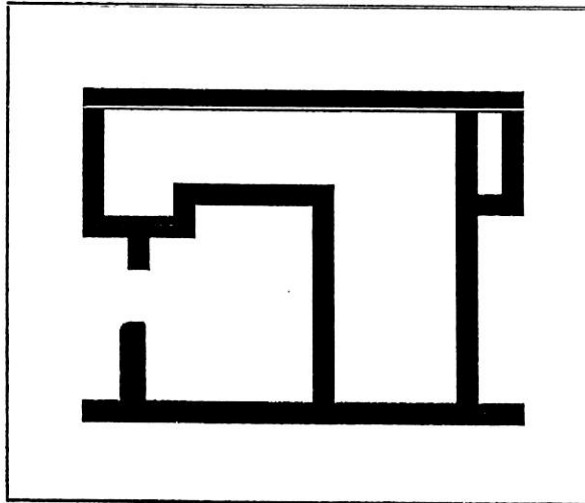

SEIKO SEWING MACHINE CO., LTD.

Notes for using this parts book

1. Parts supplied as complete assemblies are circled by a line
2. This book was prepared based on information available in August 2001.
3. Parts are subject changes in design without prior notice.

パーツブックご利用に際して

1. 組単位で補給する部品は、線で示しております。
2. この本は2001年8月のデータに基づいて作成されたものです。
3. 部品は予告なしに設計変更される場合があります。

INDEX 目次

	pages
Face plate·Upper plate 面板·上板	1,2
Arm shaft·Thread take-up lever mechanism 上軸·天秤関係	3,4
Needle bar mechanism 針棒関係	5,6
Presser foot mechanism 押え関係	7,8
Feed mechanism 送り関係	9,10
Feed dog·Feed rock shaft 送り歯·送り軸	11,12
Lower shaft mechanism 下軸関係	13,14
Thread tension 糸調子関係	15,16
Hook·Hook bracket mechanism カマ·カマ土台関係	17,18
Accessories 付属品関係	19,20
Option parts 別売品	21,22

面板·上板/Face plate·Upper plate

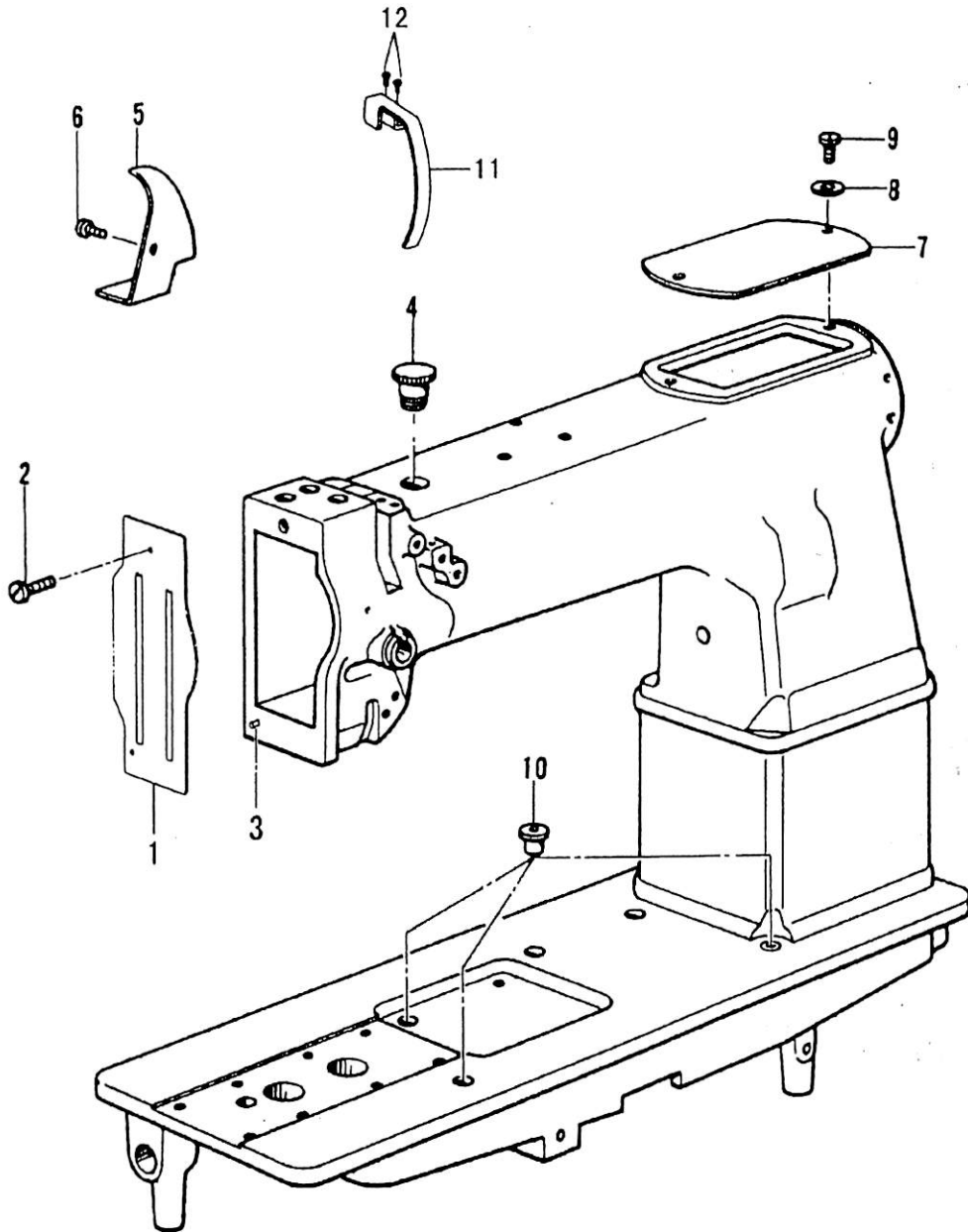

面板・上板/Face plate・Upper plate

NO.	部品番号	数量	品名	PARTS NAME
	PARTS NO.	QTY		
1	25107	1	面板	FACE PLATE
2	25108	1	止めねじ	SCREW SM9/64X40
3	25120	1	面板ピン	POSITIONING PIN
4	25112	1	油穴栓	OIL CAP
5	10551	1	天秤油受け	THREAD TAKE-UP LEVER OIL GUARD
6	25109	1	止めねじ	SCREW SM9/64X40 L=4.5
7	25113	1	上板	UPPER PLATE
8	25115	1	座金	WASHER
9	25114	1	段ねじ	HINGE SCREW SM3/16X28 L=8.5
10	25124	3	オイルカップ	OIL CAP
11	25110	1	天秤ガード	THREAD TAKE-UP LEVER COVER
12	25111	2	止めねじ	SCREW SM9/64X40 L=9

上軸・天秤關係 / Arm shaft · Thread take-up lever mechanism

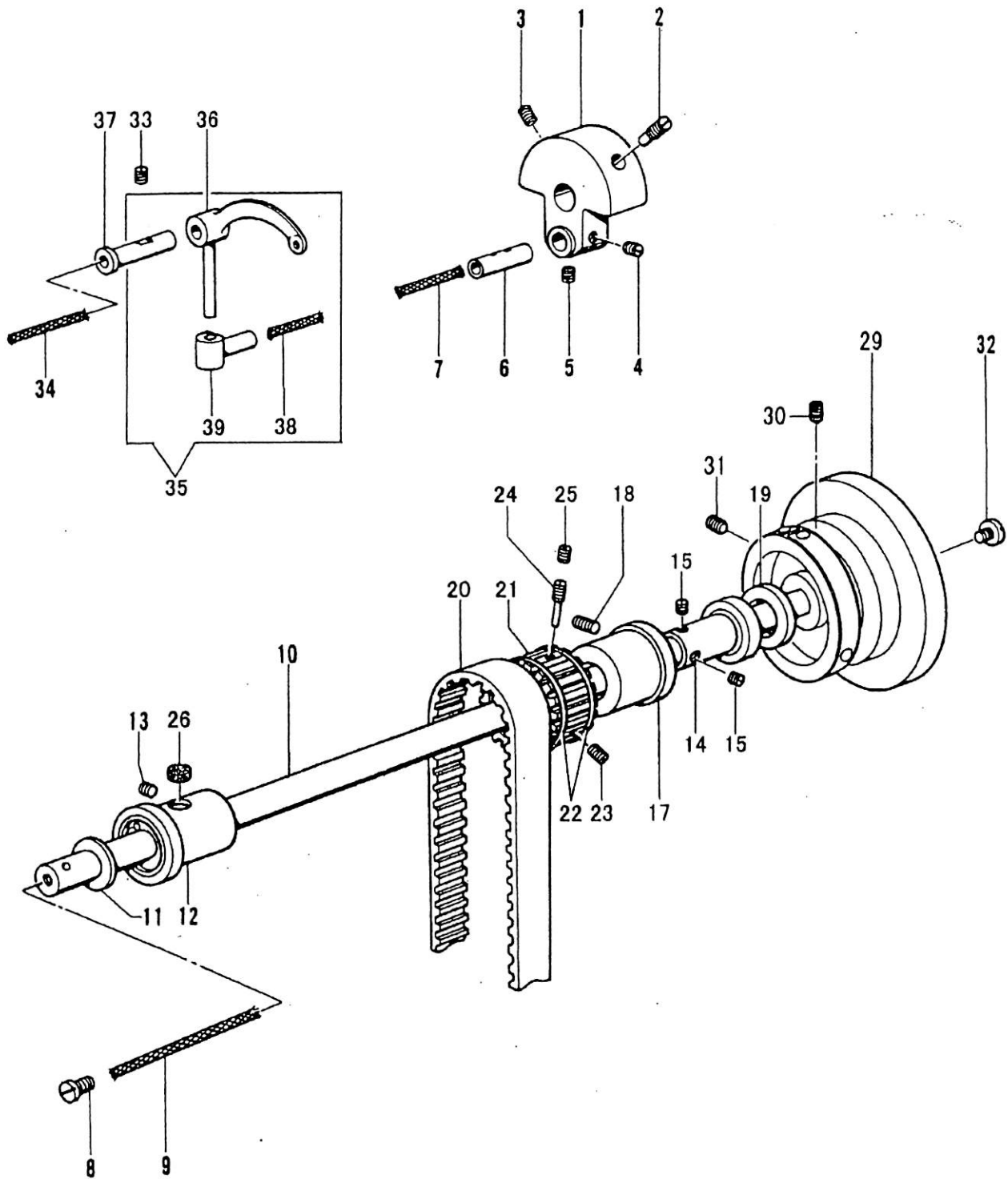

上軸・天秤関係/Arm shaft · Thread take-up lever mechanism

NO.	部品番号	数量	品名	PARTS NAME
	PARTS NO.	QTY		
1	19414	1	クランクモーションカム	CRANK MOTION CAM
2	25186	1	位置決めねじ	POSITION SCREW SM1/4X28 L=20
3	25185	1	止めねじ	SET SCREW SM1/4X28 L=14
4	25184	1	止めねじ	SET SCREW SM1/4X28 L=6
5	25183	1	止めねじ	SET SCREW SM1/4X28 L=4
6	10523	1	針棒クランクピン	NEEDLE BAR CRANK PIN
7	25182	1	油芯	OIL WICK
8	25187	1	栓ねじ	SCREW SM5/16X24 L=6
9	25188	1	油芯	OIL WICK
10	25190	1	上軸	ARM SHAFT
11	10563	1	上軸メタルワッシャー	CRANK WASHER
12	10562	1	上軸メタル(前)	ARM SHAFT BUSHING (FRONT)
13	25184	1	止めねじ	SET SCREW SM1/4X28 L=9
14	25199	1	上軸ベアリングカラー	ARM SHAFT BEARING ADAPTER SLEEVE
15	25196	2	止めねじ	SET SCREW SM1/4X32 L=20
16	25198	1	リング	RING
17	13074	1	上軸ベアリングケース	ARM SHAFT BEARING ADAPTER
18	25170	1	止めねじ	SET SCREW 17/64X32 L=5.5
19	25197	1	ベアリング	BEARING
20	25206	1	タイミングベルト	ARM SHAFT CONNECTING BELT
21	25192	1	上軸ベルトプーリ	ARM SHAFT BELT PULLEY
22	25191	2	プーリリング	PULLEY RING
23	17019A	1	止めねじ	SET SCREW SM1/4X40 L=8
24	25193	1	位置決めねじ	POSITION SCREW SM1/4X40 L=32
25	17019A	1	止めねじ	SCREW SM1/4X40 L=8
26	25189	1	フェルト	FELT
29	25200	1	プーリ	PULLEY
30	25205	1	位置決めねじ	POSITION SCREW SM15/64X28 L=21
31	25203	1	止めねじ	SET SCREW SM15/64X28 L=20
32	25204	1	押しねじ	SCREW SM11/32X28 L=11
33	25179	1	止めねじ	SET SCREW 17/64X32 L=9
34	25180	1	油芯	OIL WICK
35	10526C	1	天秤(組)	THREAD TAKE-UP LEVER COMPLETE
36	10526	1	天秤	THREAD TAKE-UP LEVER
37	10527	1	天秤ピン	THREAD TAKE-UP LEVER HINGE STUD
38	25181	1	油芯	OIL WICK
39	10529	1	天秤抱き	THREAD TAKE-UP LEVER DRIVING STUD

針棒關係/Needle bar mechanism

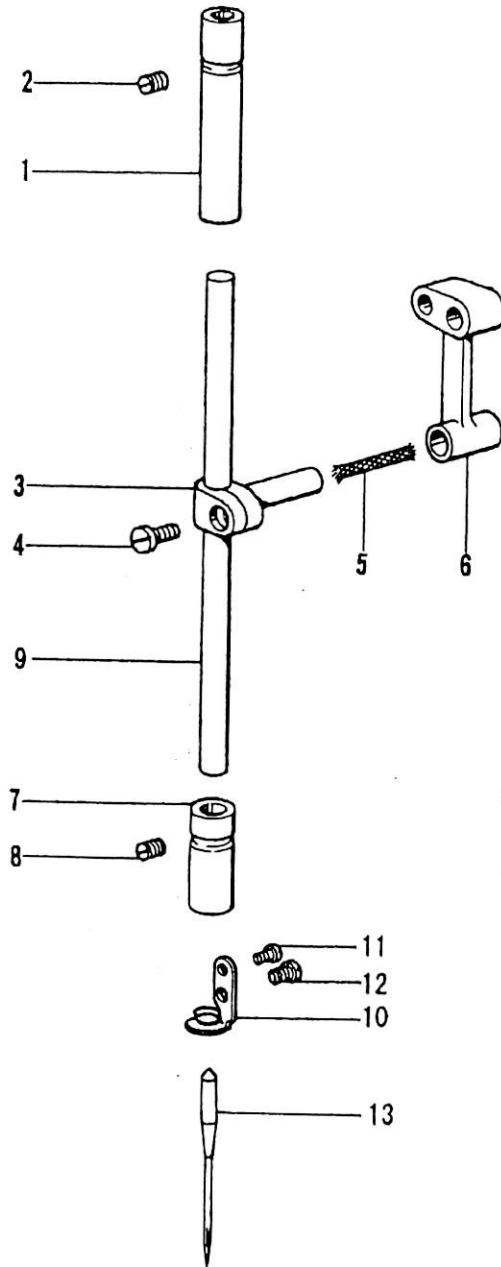

針棒関係/Needle bar mechanism

NO.	部品番号	数量	品名	PARTS NAME
	PARTS NO.	QTY		
1	25169	1	針棒メタル(上)	NEEDLE BAR BUSHING (UPPER)
2	25170	1	止めねじ	SET SCREW 17/64X32 L=20
3	25172	1	針棒抱き	NEEDLE BAR CONNECTING STUD
4	25173	1	締めねじ	PINCH SCREW M4X0.7 L=9
5	25181	1	油芯	OIL WICK
6	10520	1	針棒クランクロッド	NEEDLE BAR CONNECTING LINK
7	25174	1	針棒メタル(下)	NEEDLE BAR BUSHING (LOWER)
8	25170	1	止めねじ	SET SCREW 17/64X32 L=20
9	25171	1	針棒	NEEDLE BAR
10	25176	1	針棒系掛け	NEEDLE BAR THREAD GUIDE
11	25175	1	止めねじ	SCREW SM3/32X56 L=2.8
12	25177	1	止めねじ	SET SCREW SM9/64X40 L=4.5
13	N1314	1	針 DP-F22 #14	NEEDLE DP-F22 #14

押え関係/Presser foot mechanism

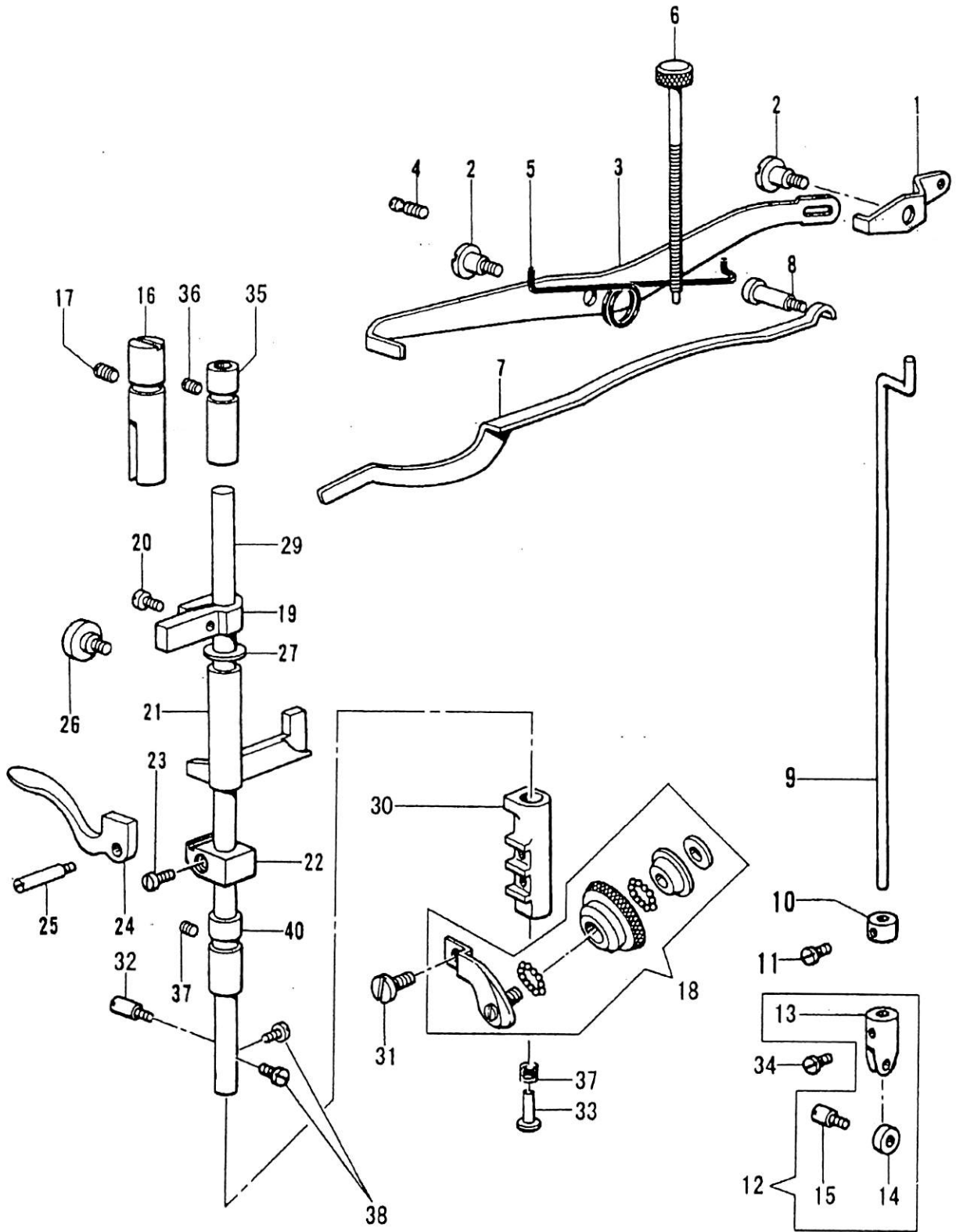

押え関係/Presser foot mechanism

NO.	部品番号	数量	品名	PARTS NAME
	PARTS NO.	QTY		
1	25227	1	小弓	KNEE LIFTER CONNECTING LEVER
2	25224	2	段ねじ	HINGE SCREW
3	25222	1	大弓	KNEE LIFTER LIFTING LEVER
4	25223	1	弓ばね掛け	SCREW SM1/4X28
5	25226	1	弓ばね	SPRING
6	25225	1	大板ばね調節ねじ	REGULATING SCREW 17/64X32 L=88
7	25220	1	大板ばね	PRESSER BAR SPRING (FLAT)
8	25221	1	段ねじ	STUD SCREW SM1/4X28 L=31
9	25228	1	吊り棒	KNEE LIFTER CONNECTING LEVER LIFTING ROD
10	25229	1	吊り棒カラー	LIFTING ROD COLLAR
11	25230	1	止めねじ	SCREW SM11/64X32 L=8
12	25232C	1	吊り棒土台(組)	LIFTING ROD BRACKET COMPLETE
13	25232	1	吊り棒土台	LIFTING ROD ROLLER BRACKET
14	25233	1	吊り棒土台ローラー	LIFTING ROD ROLLER
15	25234	1	ピンねじ	ROLLER SET SCREW SM9/64X40 L=13
16	10543	1	案内棒	PRESSER BAR POSITION GUIDE
17	25163	1	止めねじ	SET SCREW 17/64X32 L=20
18	25217	1	ローラー押え(組)	ROLLER PRESSER FOOT COMPLETE
19	25208	1	押え棒案内	PRESSER BAR POSITION GUIDE BRACKET
20	25209	1	締めねじ	PINCH SCREW 9/64X40 L=7
21	25211	1	押え棒抱き	PRESSER BAR LIFTING BRACKET
22	13360	1	大板ばね受け	PRESSER BAR SPRING BRACKET
23	25173	1	締めねじ	PINCH SCREW M4X0.7 L=9
24	10659	1	押え上げレバー	PRESSER BAR LIFTER
25	25164	1	ピンねじ	HINGE SCREW SM1/4X28 L=24
26	25210	1	段ねじ	LIFTING BRACKET GUIDE SCREW SM1/4X40 L=16.5
27	25314	1	ばね座金	SPRING WASHER
29	25207	1	ローラー押え棒	ROLLER PRESSER BAR
30	25214	1	ローラー押え土台	ROLLER PRESSER BAR BRACKET
31	25218	1	ローラー押え止めねじ	ROLLER PRESSER FOOT SCREW
32	25213	1	位置決めねじ	POSITION SCREW
33	25216	1	押え棒ピン	PRESSER BAR PIN
34	25231	1	止めねじ	SCREW SM11/64X32 L=8
35	10538	1	押え棒メタル(上)	PRESSER BAR BUSHING (UPPER)
36	25170	1	止めねじ	SET SCREW 17/64X32 L=20
37	25170	1	止めねじ	SET SCREW 17/64X32 L=20
38	25177	2	押え棒ピン止めねじ	PRESSER BAR PIN SET SCREW
39	25215	1	土台スプリング	SPRING
40	25212	1	押え棒メタル(下)	PRESSER BAR BUSHING (LOWER)

送り関係/Feed mechanism

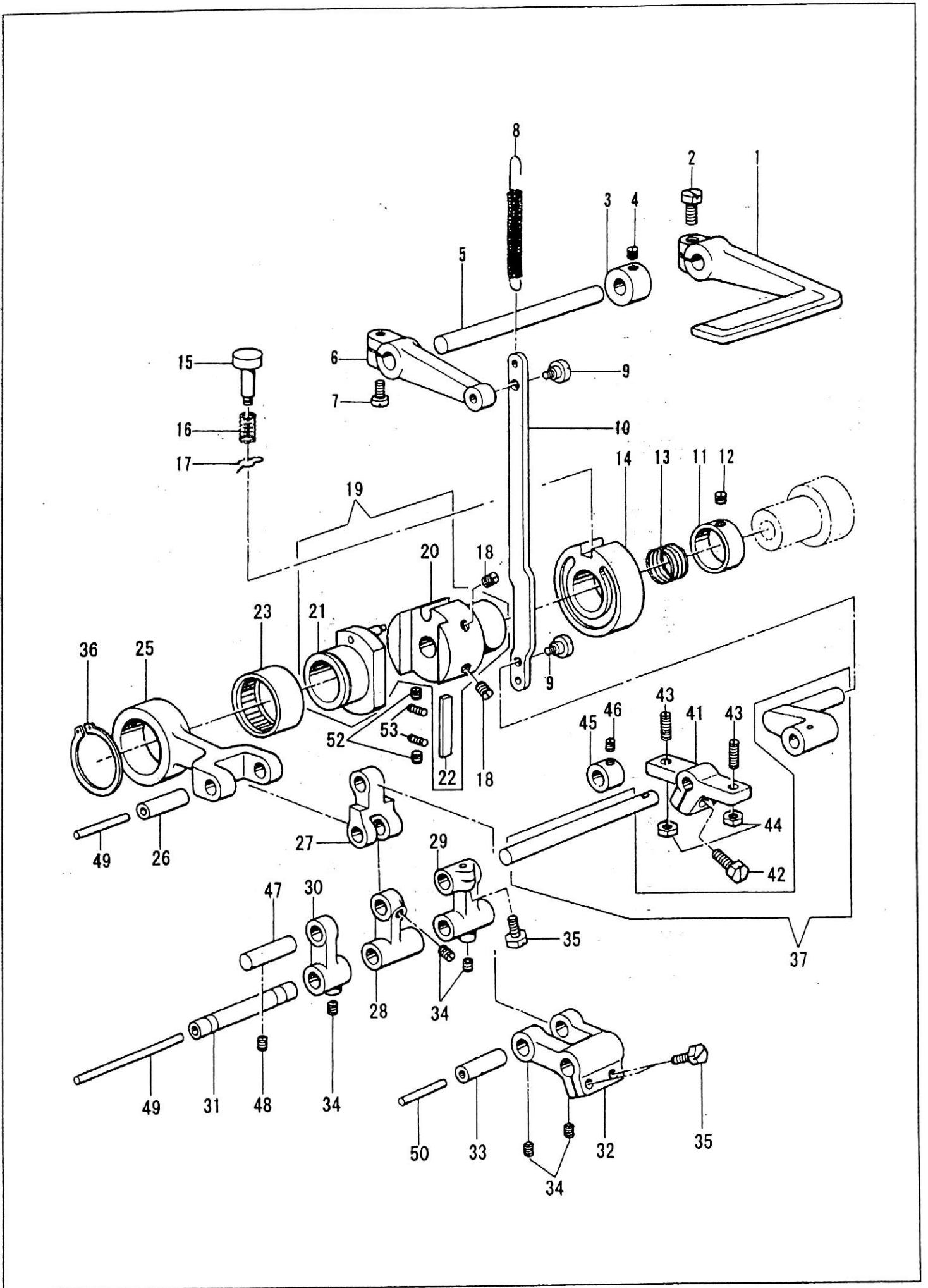

送り関係/Feed mechanism

NO.	部品番号	数量	品名	PARTS NAME
	PARTS NO.	QTY		
1	25235	1	バックレバー	FEED REVERSING LEVER
2	10845	1	締めねじ	PINCH SCREW SM15/64X28 L=18
3	25270	1	カラー	COLLAR
4	25271	1	止めねじ	SET SCREW SM15/64X28 L=8
5	25269	1	バックレバー軸	FEED REVERSING LEVER SHAFT
6	25265	1	バックレバー軸だるま	FEED REVERSING LEVER SHAFT CRANK
7	25267	1	締めねじ	PINCH SCREW SM15/64X28 L=7
8	25268	1	バックレバースプリング	SPRING
9	25274	2	段ねじ	HINGE SCREW SM1/4X28
10	25273	1	バック連結ロッド	FEED REVERSING CONNECTING ROD
11	25250	1	押しリング	RING
12	25196	2	止めねじ	SET SCREW SM1/4X32 L=5.5
13	25249	1	押しリングスプリング	SPRING
14	25248	1	渦巻きカム	ADJUSTING DISC
15	25320	1	押しボタン	FEED REGULATING STUD (SMALL)
16	25321	1	押しボタンスプリング	SPRING
17	25322	1	押しボタン止めピン	PIN
18	10766-G	2	止めねじ	SET SCREW SM1/4X32 L=12
19	25246C	1	送りカム(組)	FEED DRIVING CAM COMPLETE
20	25246	1	送りカム土台	FEED DRIVING FLANGE
21	25245	1	送りカム	FEED DRIVING CAM
22	25247	1	案内板	FEED DRIVING ECCENTRIC FRICTION GIBE
23	25244	1	ニードルベアリング	NEEDLE BEARING
25	11951	1	下送りロッド	FEED DRIVING ECCENTRIC CONNECTION
26	11962	1	下送りロッドピン	HINGE PIN
27	11955	1	二又リンク	FEED DRIVING ECCENTRIC CONNECTION LINK
28	11956	1	連結リンク	FEED REVERSING SHAFT CRANK LINK
29	16707	1	切り換えクランク(右)	FEED REVERSING SHAFT CRANK
30	11958	1	切り換えクランク(左)	FEED REVERSING MECHANISM SUPPORT LINK
31	31209	1	ピン	STUD
32	16708	1	連結レバー	FEED ROCK SHAFT CRANK
33	11962	1	ピン	FEED ROCK SHAFT CRANK STUD
34	11953	5	止めねじ	SET SCREW SM7/32X32 L=5
35	19420	3	締めねじ	PINCH SCREW SM1/4X24 L=23
36	25243	1	止め輪	SNAP RING
37	25275C	1	バック土台軸ホルダー(組)	FEED REVERSING SHAFT COMPLETE
41	25261	1	スタッド	FEED REVERSING SHAFT BRACKET
42	19420	1	締めねじ	PINCH SCREW SM1/4X28 L=16
43	25263	2	調節ねじ	REGULATING SCREW M5X0.8
44	25264	2	ナット	NUT
45	25276	1	カラー	COLLAR
46	25277	2	止めねじ	SET SCREW SM1/4X32 L=4.5
47	25259	1	ピン	FEED REVERSING MECHANISM SUPPORT LINK STUD
48	25325	1	止めねじ	SET SCREW SM1/4X32
49	25260	2	油芯	OIL WICK
50	25258	1	油芯	OIL WICK
52	10630	2	止めねじ	SET SCREW SM1/8X40 L=5
53	10629	2	止めねじ	SET SCREW SM1/8X40 L=8