

# SEIKO

## PARTS LIST

### SKZ-6B-26R

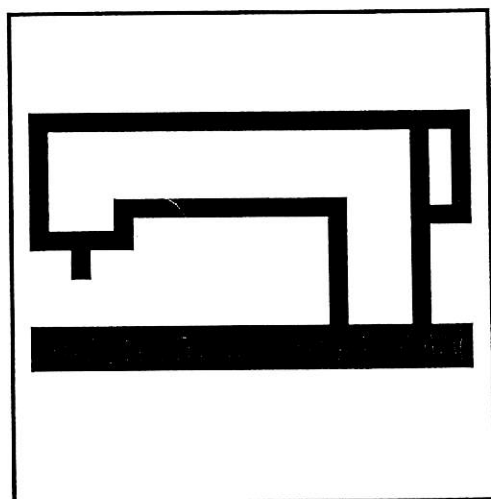

SEIKO SEWING MACHINE CO.,LTD.

1. MAIN PARTS NAME

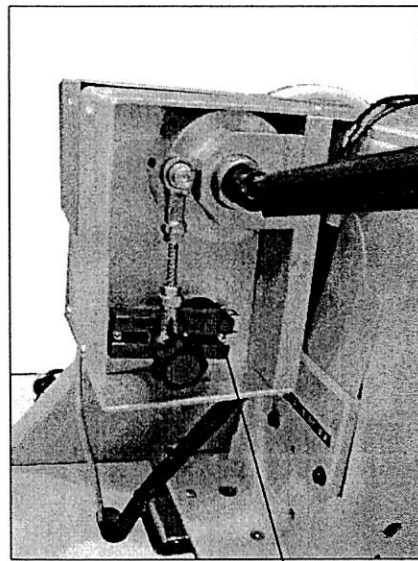
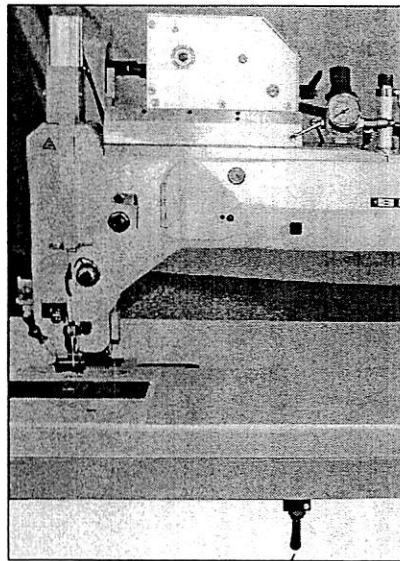
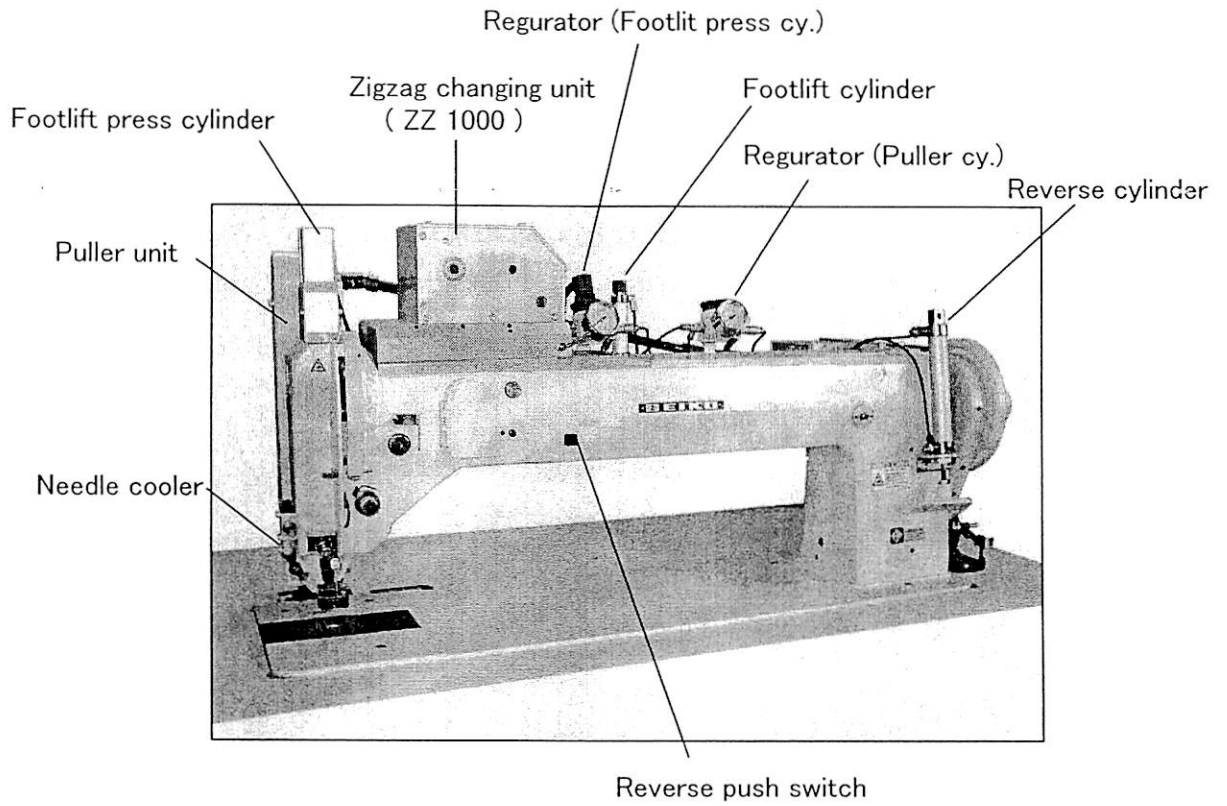

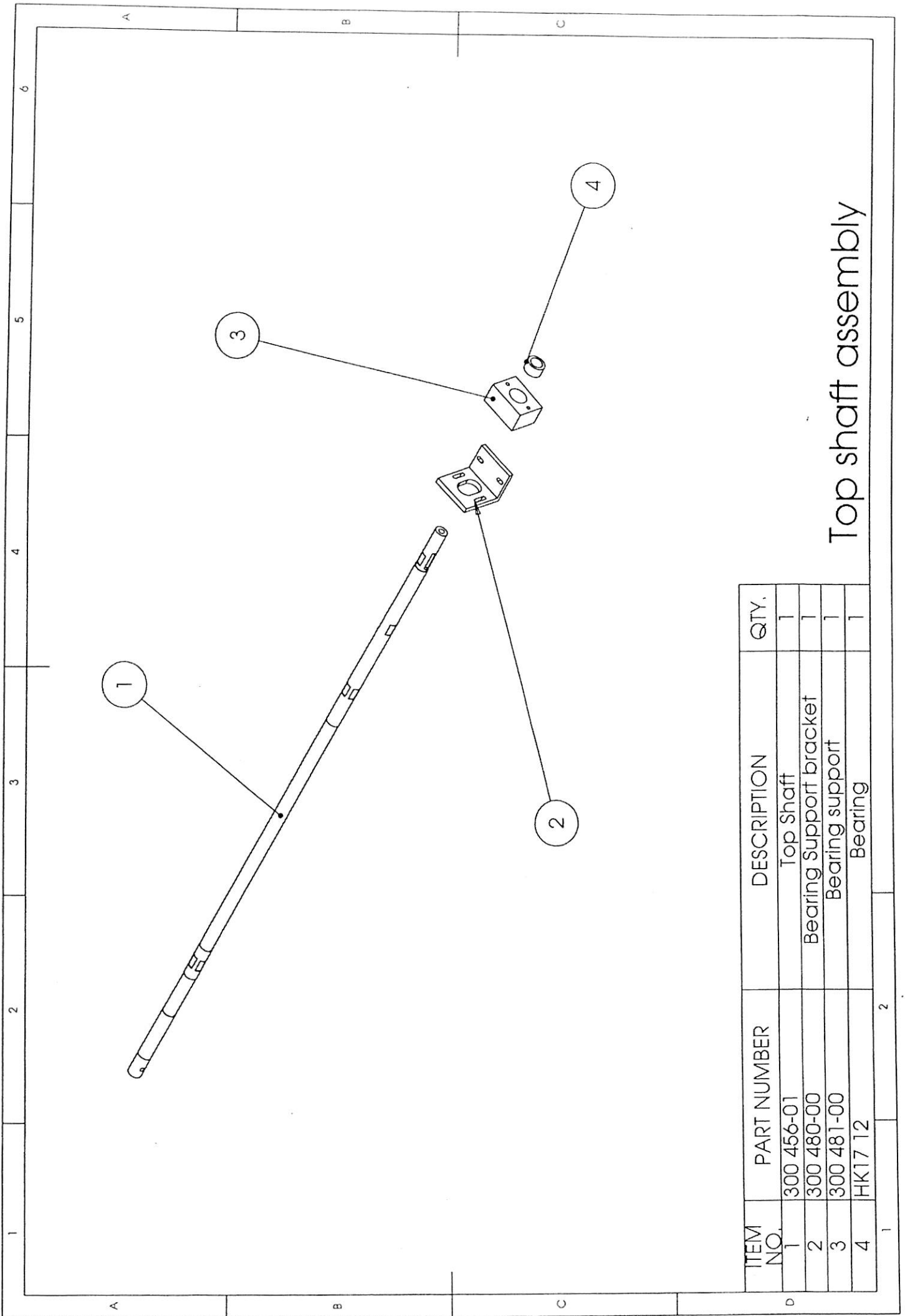

# Top shaft assembly

ITEM NO.	PART NUMBER	DESCRIPTION	QTY.
1	300 456-01	Top Shaft	1
2	300 480-00	Bearing Support bracket	1
3	300 481-00	Bearing support	1
4	HK17 12	Bearing	1

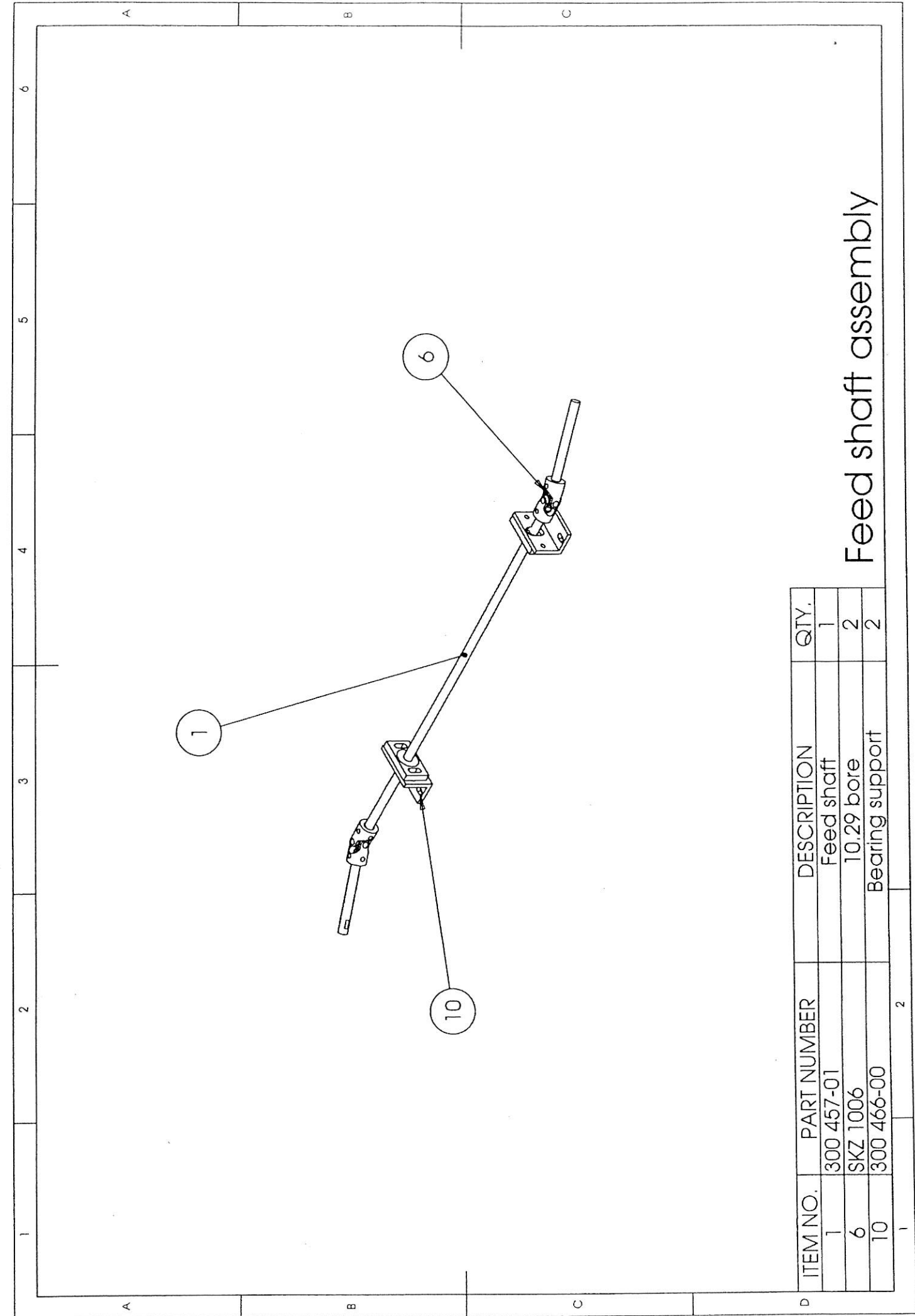

# Feed shaft assembly

ITEM NO.	PART NUMBER	DESCRIPTION	QTY.
1	300 457-01	Feed shaft	1
6	SKZ 1006	10.29 bore	2
10	300 466-00	Bearing support	2
1			2

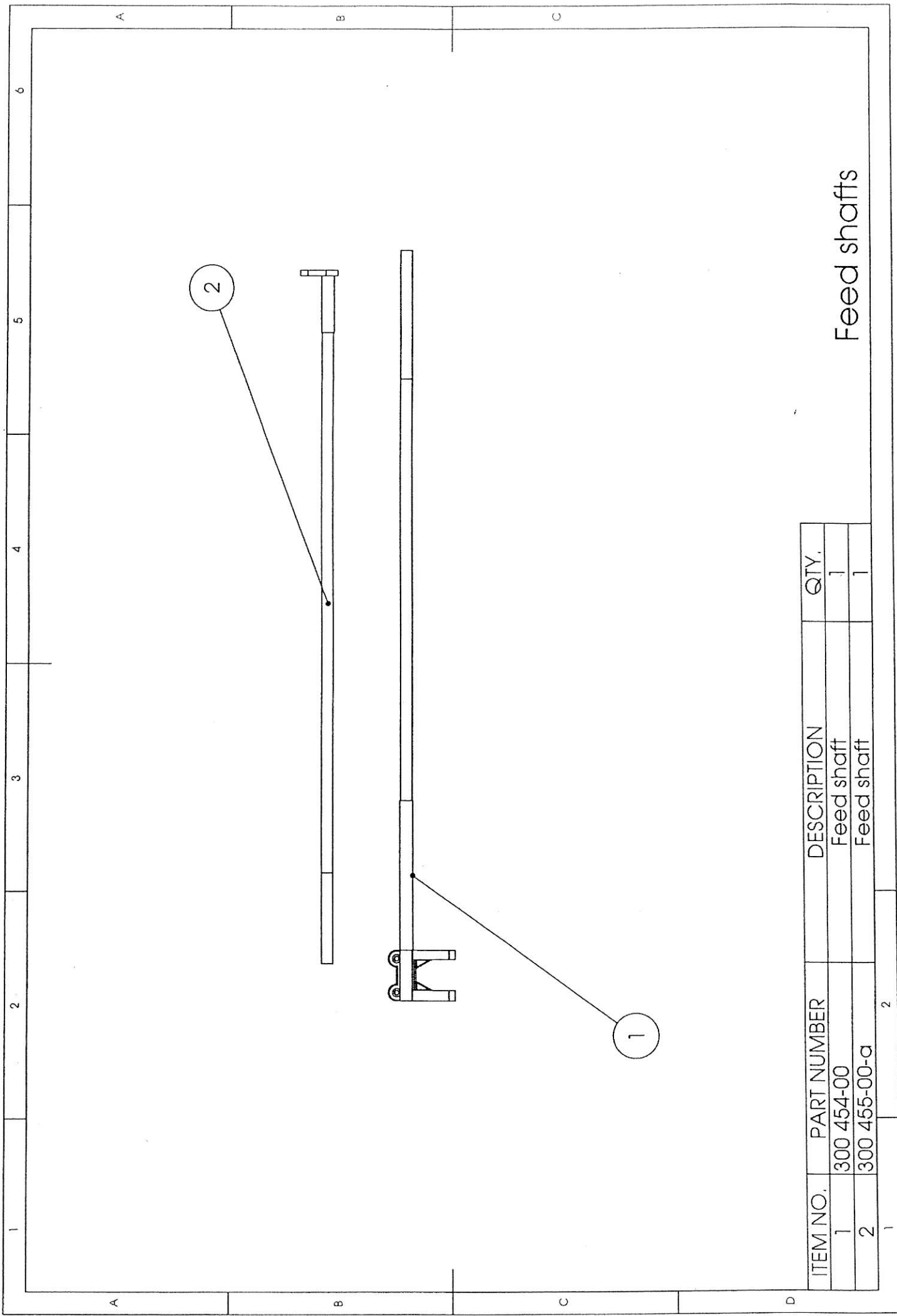

ITEM NO.	PART NUMBER	DESCRIPTION	QTY.
1	300 454-00	Feed shaft	1
2	300 455-00-a	Feed shaft	1

Feed shafts

4

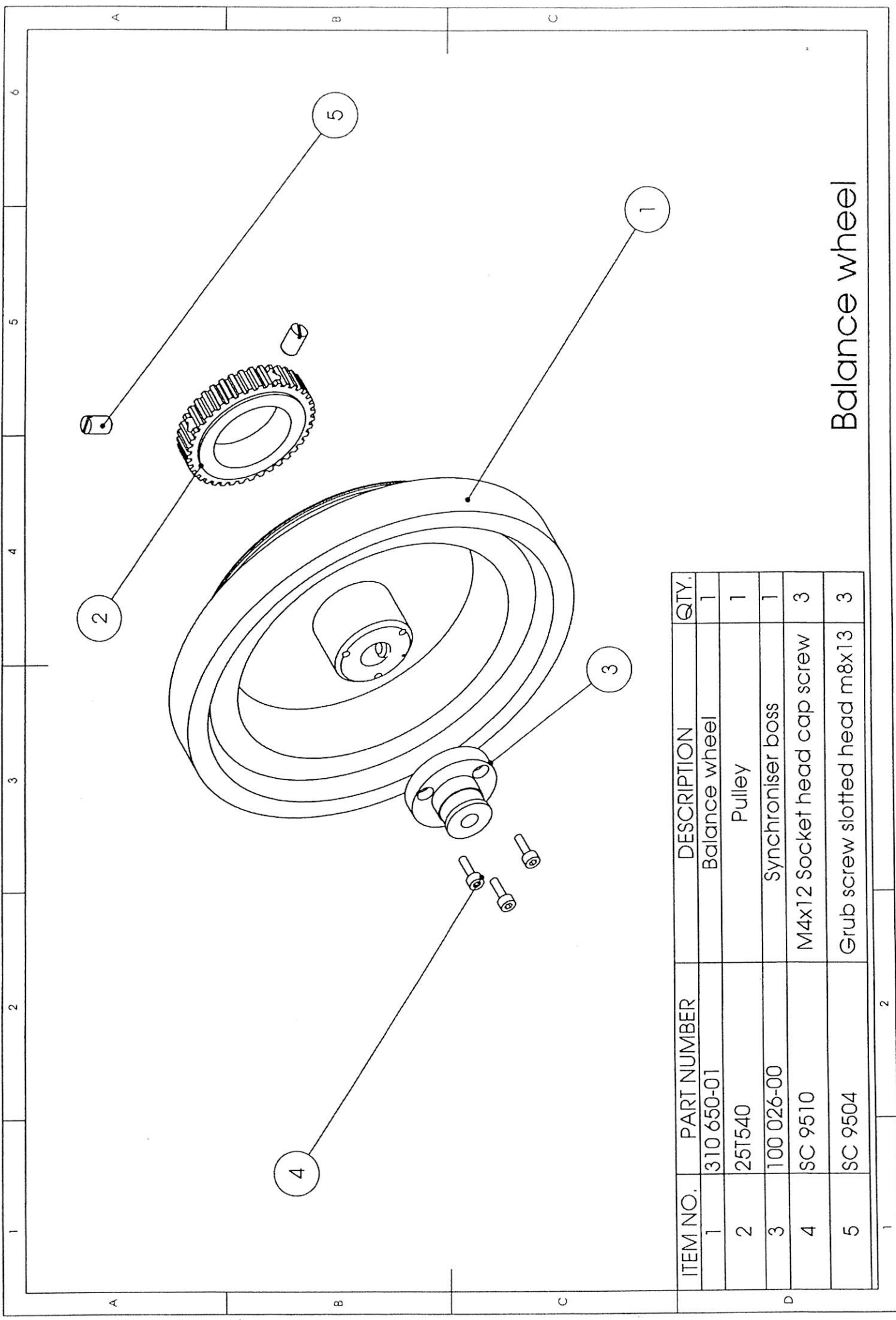

ITEM NO.	PART NUMBER	DESCRIPTION	QTY.
1	310 650-01	Balance wheel	1
2	25T540	Pulley	1
3	100 026-00	Synchroniser boss	1
4	SC 9510	M4x12 Socket head cap screw	3
5	SC 9504	Grub screw slotted head m8x13	3
1	2		

Balance wheel

ITEM NO.	PART NUMBER	DESCRIPTION	QTY.
1	skz 1001-1	Back plate	1
2	skz 1001-2	Bottom plate	1
3	skz 1001-3	Top plate	1
4	SC 9510	M4x12 Socket head cap screw	4
5	skz 1001-4	Footlift bracket guard	1
6	SC 9512	Panhead screw M4x10	2
7	SSO 22	Footlift cylinder	1
8	SKZ 1005	5mm stud	1
9	SC 9517	M5x60 Socket head cap screw	4
10	1393	Presser bar	1
11	SC 9602	Hexagon Nut 5mm	1

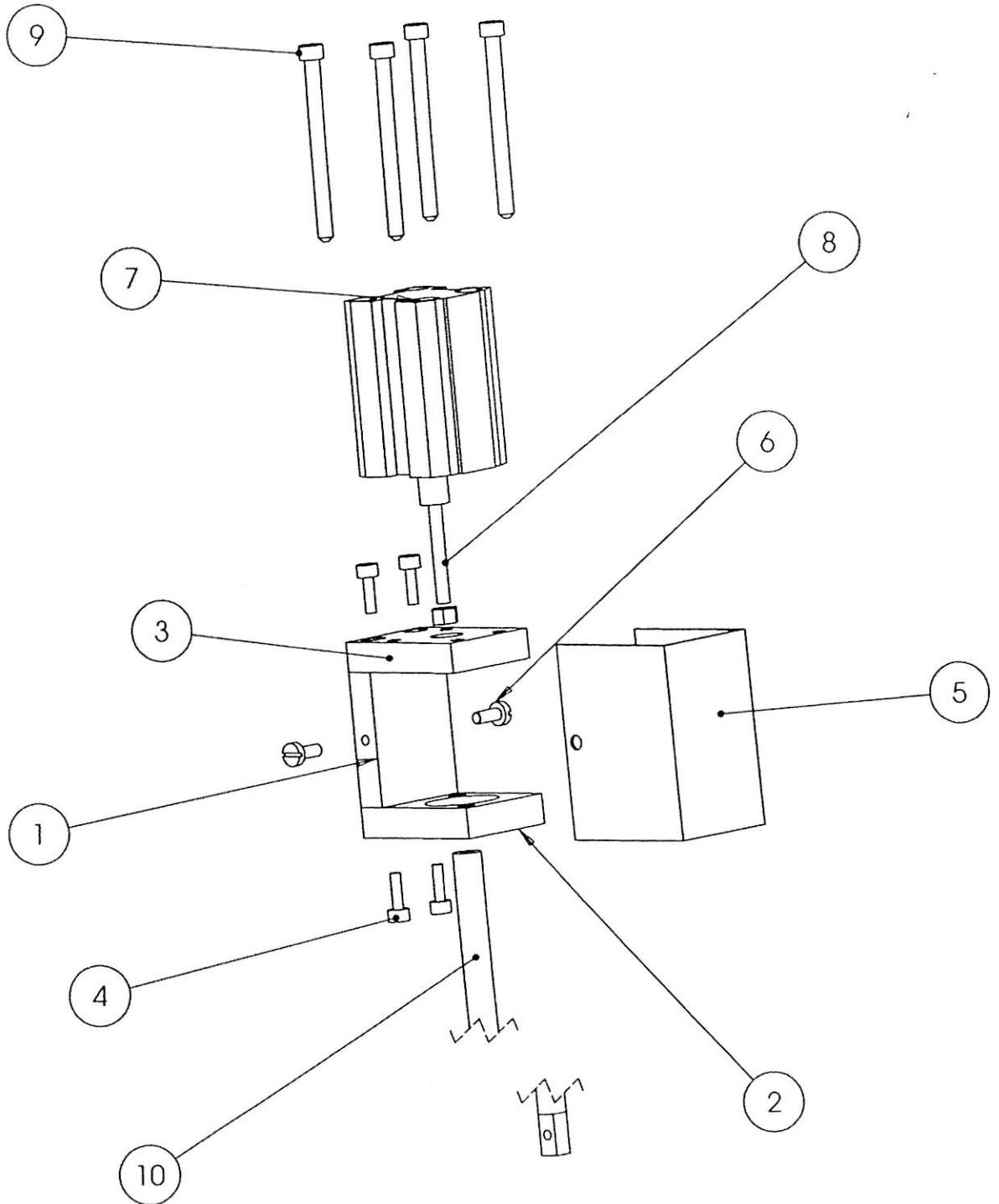

Pneumatic footlift assembly

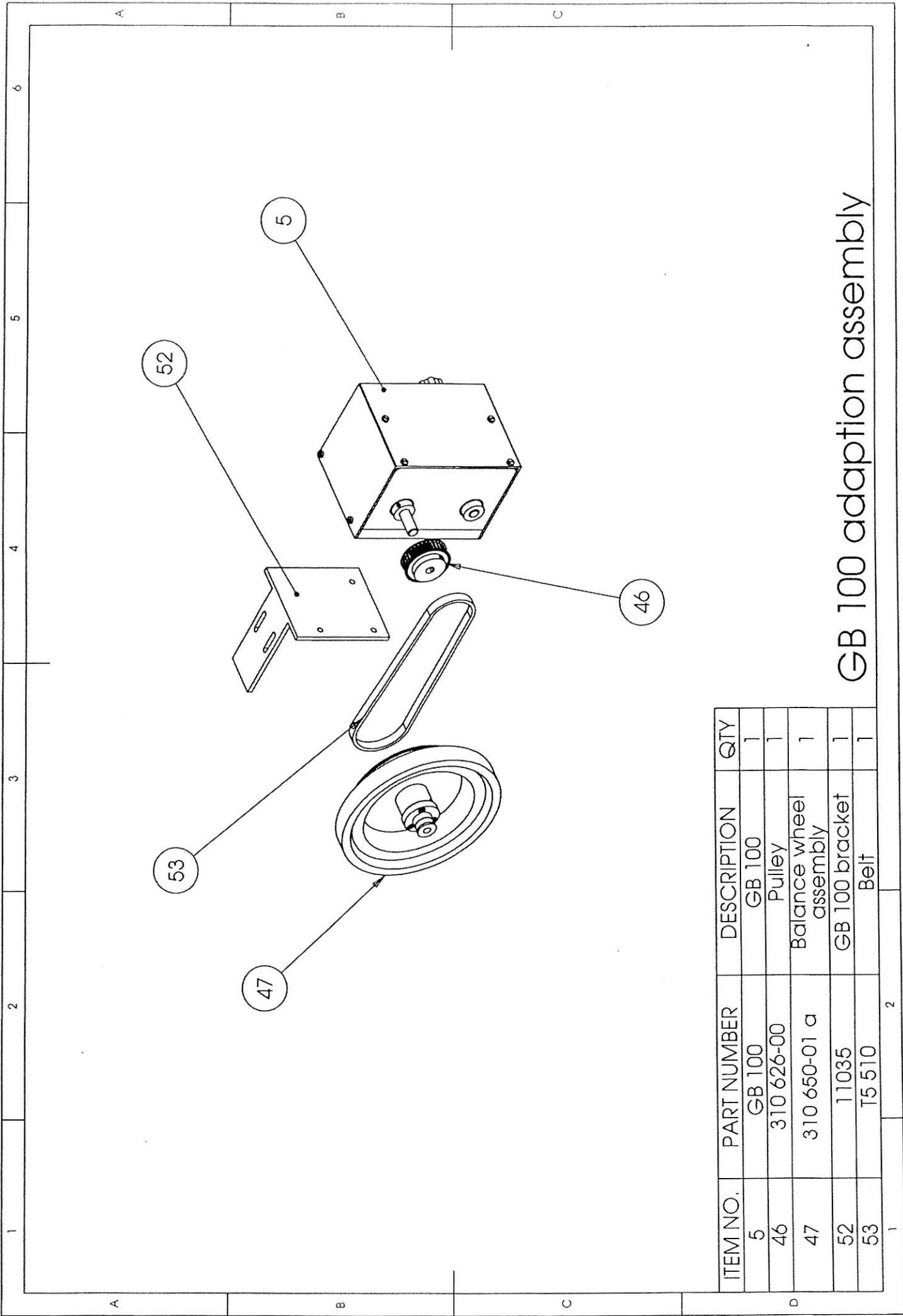

ITEM NO.	PART NUMBER	DESCRIPTION	QTY
5	GB 100	GB 100	1
46	310 626-00	Pulley	1
47	310 650-01 a	Balance wheel assembly	1
52	11035	GB 100 bracket	1
53	T5 510	Belt	1
1			2

GB 100 adaption assembly



ITEM NO.	PART NUMBER	DESCRIPTION	QTY
1	310 630-00	Mounting plate	1
2	310 625-00	Spacer block	1
5	ZZ 1000 602	ZZ 1000	1
30	310 626-00	Pulley	2
43	310 623-00	Clamp	1
44	310 624-00	Link	1
46	SC 402	5mm Male rod end	1
47	SC 9518	Bolt	1
48	SC 9600	Nut	1
50	SC 5913	Bolt	1
51	T5 455	Belt	1
52	300 460-00	Adaption shaft	1
53	310 629-00	Belt guard	1
45	SC 400	6mm female rod end	1

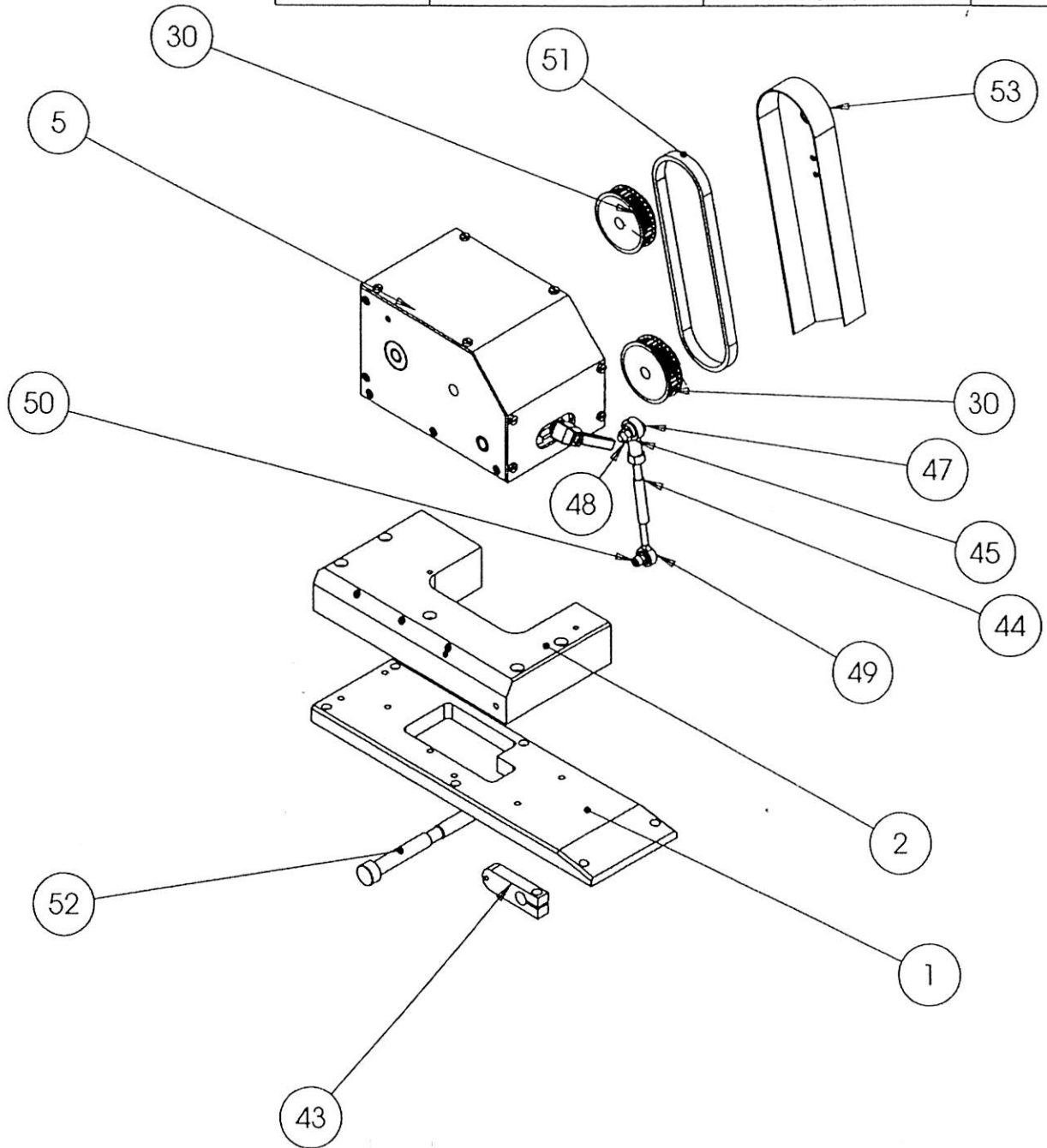

ZZ 1000 adaption assembly

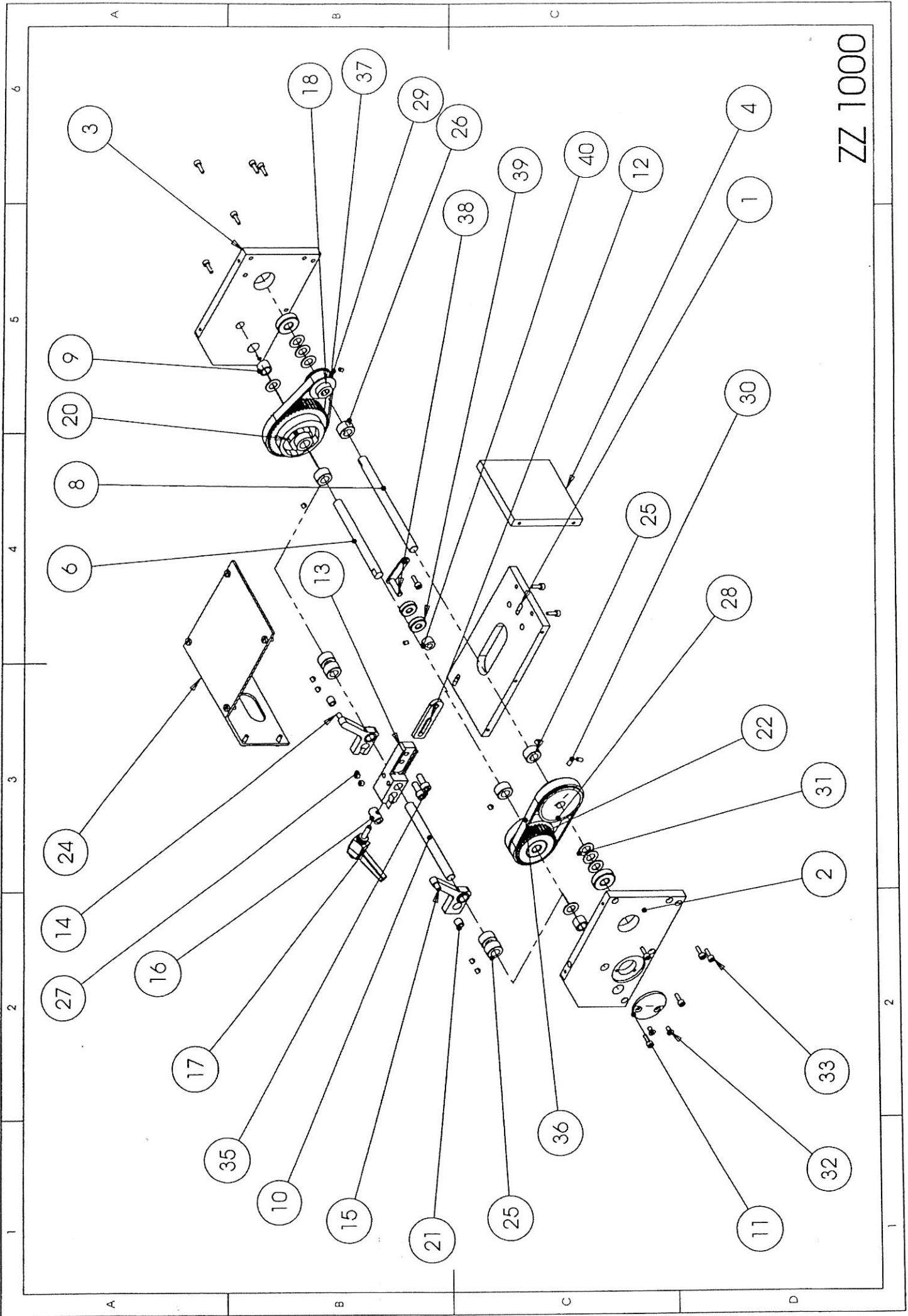

ZZ 1000

ITEM NO.	PART NUMBER	DESCRIPTION	QTY.
1	310 601-00	Base Plate	1
2	310 602-00	Left side plate	1
3	310 603-00	Right side plate	1
4	310 604-00	Back plate	1
5	310 607-00	Lid	1
6	310 615-00	Cam shaft	1
8	310 616-00	Drive shaft	1
9	10x14x10	Bush	4
10	310 614-00	Gear shaft	1
11	310 621-00	Side cover plate	1
12	310 610-00	Lever	1
13	310 608-00	Middle lever	1
14	310 605-00	Left cam follower	1
15	310 606-00	Left cam follower	1
17	930-344-41211	Handle	1
18	310 613-00	3 step pulley	1
20	111 033-00	6 point cam	1
21	111 023-00	Cam follower roller	2
23	111 031-00	Zigzag cam	1
24	SC 9512	Panhead screw M4x10	8
25	310 611-00	Bush	8
26	SC 9502	Grub screw M5x5	8
27	SC 9503	Grub screw M6x5	2
28	310 612-00	Z32 pulley	1
29	SC 9500	Grub screw M4x5	3
30	SC 9501	Grub screw M4x8	2
31	GTM-1018-010	Nylon washer	8
32	SC 9509	M4x5 Countersunk	2
33	SC 9510	M4x12 Socket head cap screw	13
34	CTL-655-0239k	Pin	2
35	SC 9515	M6x16 Socket head cap screw	2
36	T5x295	Zigzag belt	1
37	T5x305	3 step belt	1
38	310 622-00	Belt tensioner	1
39	6001-2rs	Bearing 12x28x8	2
40	930-410	Belt tension collar	1

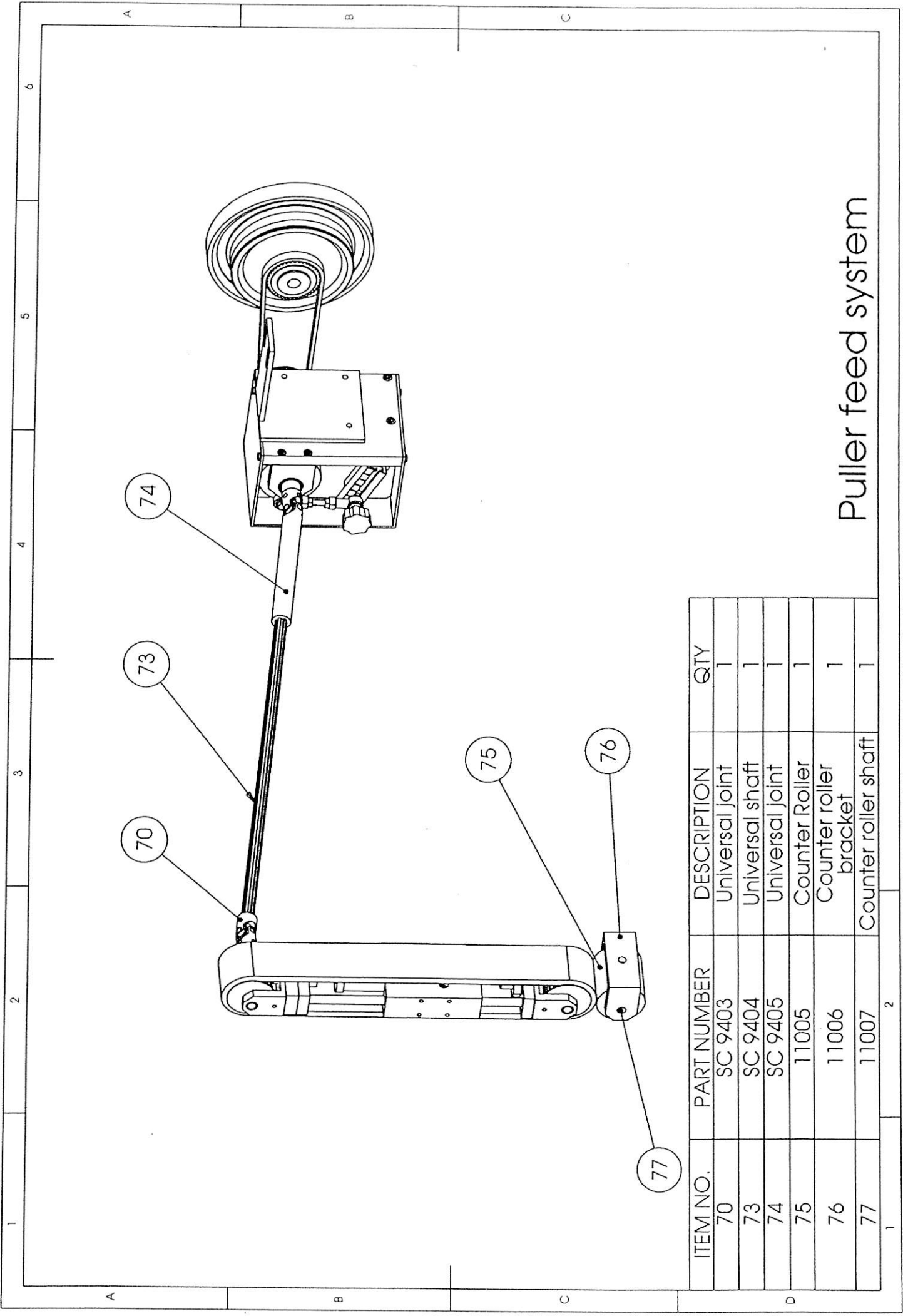

ITEM NO.	PART NUMBER	DESCRIPTION	QTY
70	SC 9403	Universal joint	1
73	SC 9404	Universal shaft	1
74	SC 9405	Universal joint	1
75	11005	Counter Roller	1
76	11006	Counter roller bracket	1
77	11007	Counter roller shaft	1

Puller feed system

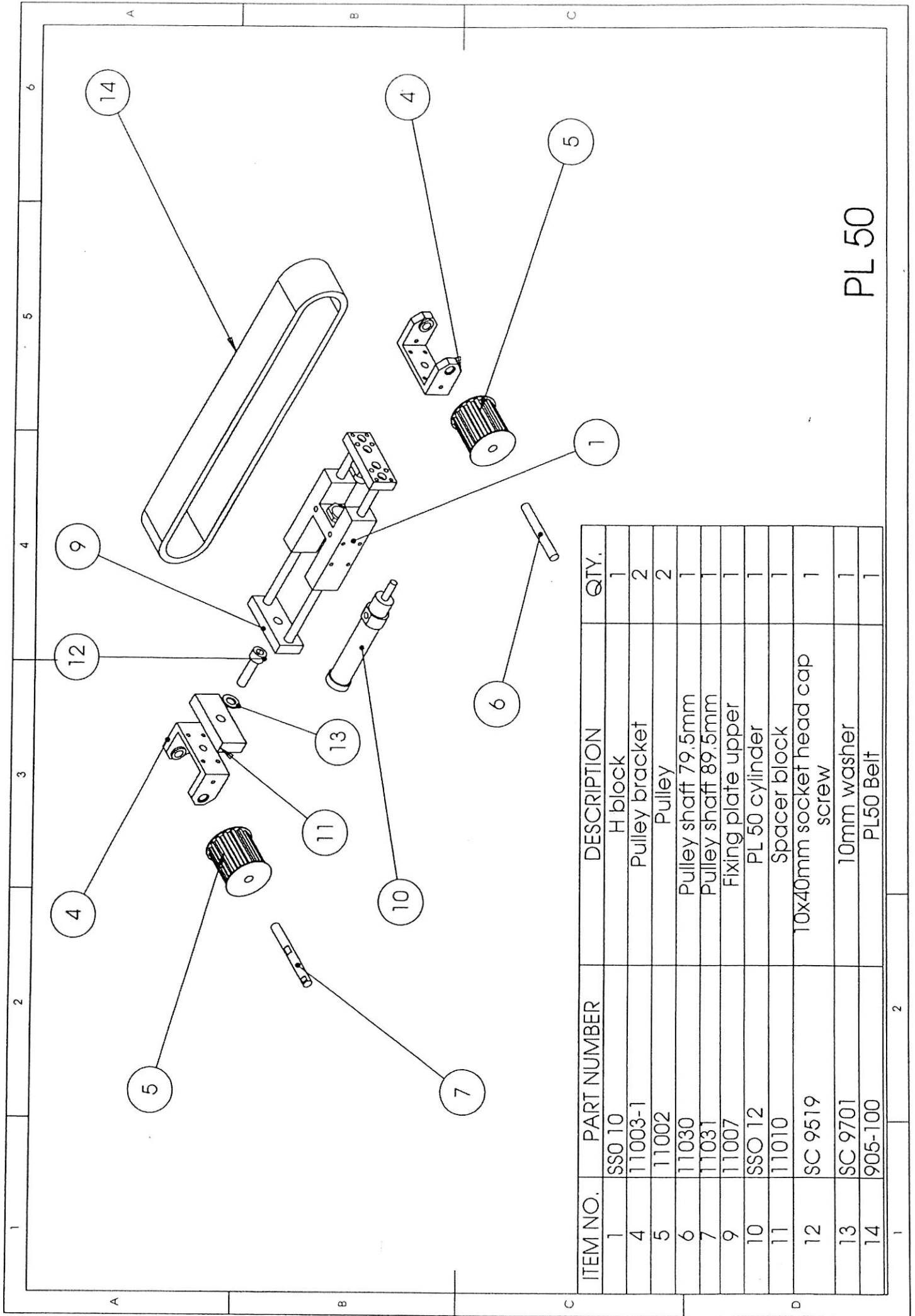

PL 50

ITEM NO.	PART NUMBER	DESCRIPTION	QTY.
1	SS0 10	H block	1
4	11003-1	Pulley bracket	2
5	11002	Pulley	2
6	11030	Pulley shaft 79.5mm	1
7	11031	Pulley shaft 89.5mm	1
9	11007	Fixing plate upper	1
10	SSO 12	PL 50 cylinder	1
11	11010	Spacer block	1
12	SC 9519	10x40mm socket head cap screw	1
13	SC 9701	10mm washer	1
14	905-100	PL50 Belt	1

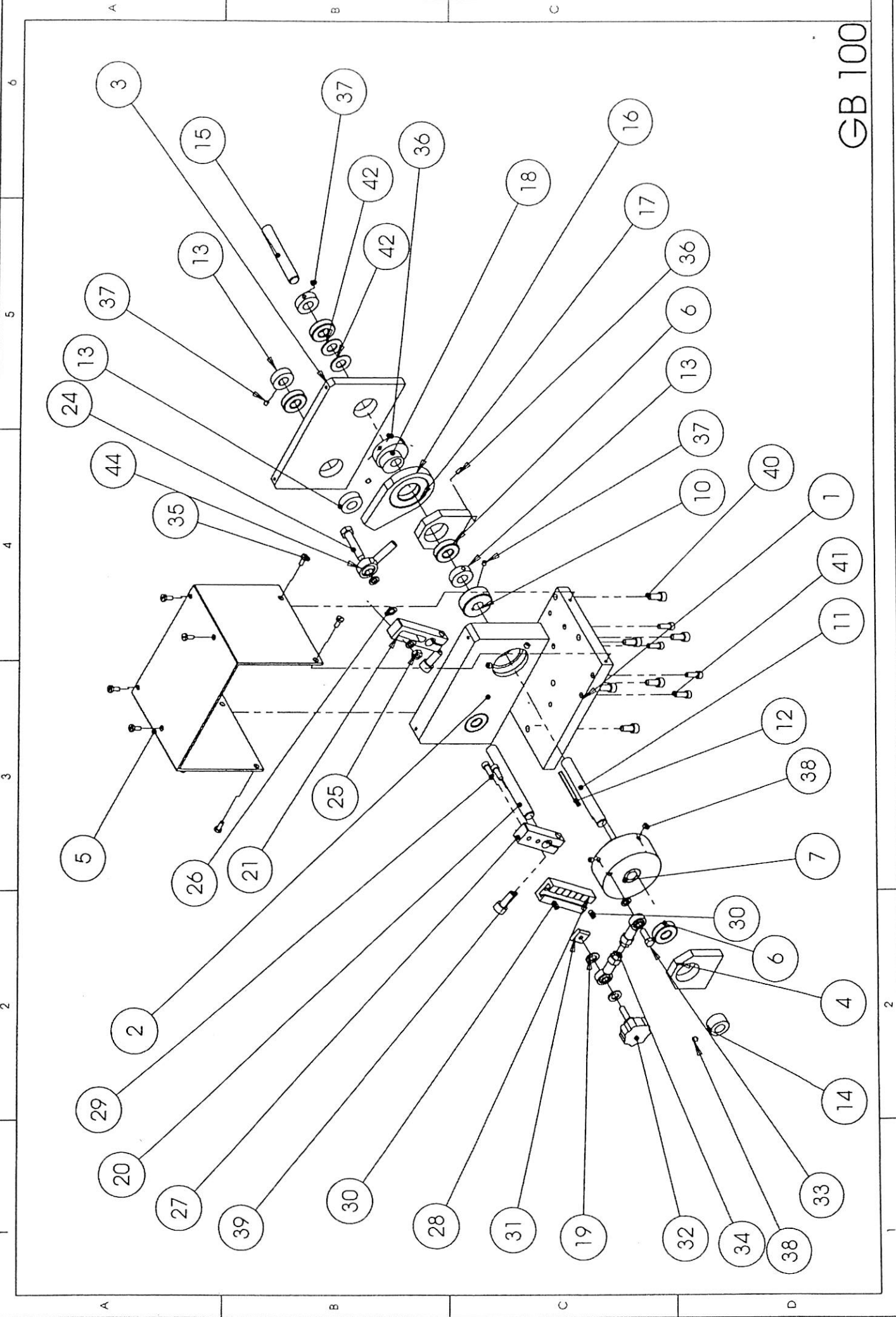

ITEM NO.	PART NUMBER	DESCRIPTION	QTY.
1	11103	Base plate	1
2	11100	Centre plate	1
3	11101	Side plate	1
4	11102	Bearing support plate	2
5	11110	Lid	1
6	6001-2rs	Bearing 12x28x8	5
7	GL 12	Clutch bearing	1
8	11104	Clutch bearing housing	1
9	16004zz	Bearing 20x42x8	1
10	USNU12	Stop bearing	1
11	11107	Shaft	1
12	11142	Key	1
13	11141	Bush	4
14	11140	Bush	1
15	11136	Shaft	1
16	11112	Eccentric housing	1
17	16005 zz	Bearing 25x47x8	1
18	11111	Eccentric	1
19	11145	Washer	2
20	11137	Shaft	1
21	11108	Clamp	1
22	SC 9400	6mm rod end	2
24	11105	Clamp	1
25	11106	Slide guide block	1
26	11138	Slide block	1
27	11144	Handle	1
28	11146	6mm Stud	1
29	11143	Washer	2
30	SC 9401	8mm Male Rod end	1
32	SC 9507	Hexagon Head Bolt 8x36mm	1
33	SC 9600	Hexagon Nut 6mm	3
34	SC 9700	6mm washer	4
35	SC 9511	M5 Socket head cap screw	2
36	SC 9505	Grub screw M5x10	2
37	SC 9506	Hexagon Head Bolt 6x16	1
38	SC 9512	Panhead screw M4x10	8
39	SC 9501	Grub screw M4x8	2
40	SC 9500	Grub screw M4x5	4
41	SC 9502	Grub screw M5x5	3
42	SC 9516	M8x20Socket head cap screw	2
43	SC 9515	M6x16 Socket head cap screw	6
44	SC 9514	M5x16 Socket head cap screw	4
45	SC 9503	Grub screw M6x5	2

## SEIKO SEWING MACHINE CO., LTD.

2-13-6 Sakaecho, Funabashi-shi Chiba Prefecture,  
273-0018, Japan

TEL: 81-47-420-3561 (Overseas dept.)

FAX: 81-47-420-3560

E-mail: [export@seiko-sewing.co.jp](mailto:export@seiko-sewing.co.jp)

<http://www.seiko-sewing.co.jp/>