

針振りギヤー、上板/ZIGZAG GEAR, ARM TOP COVER
SKZ-6BR

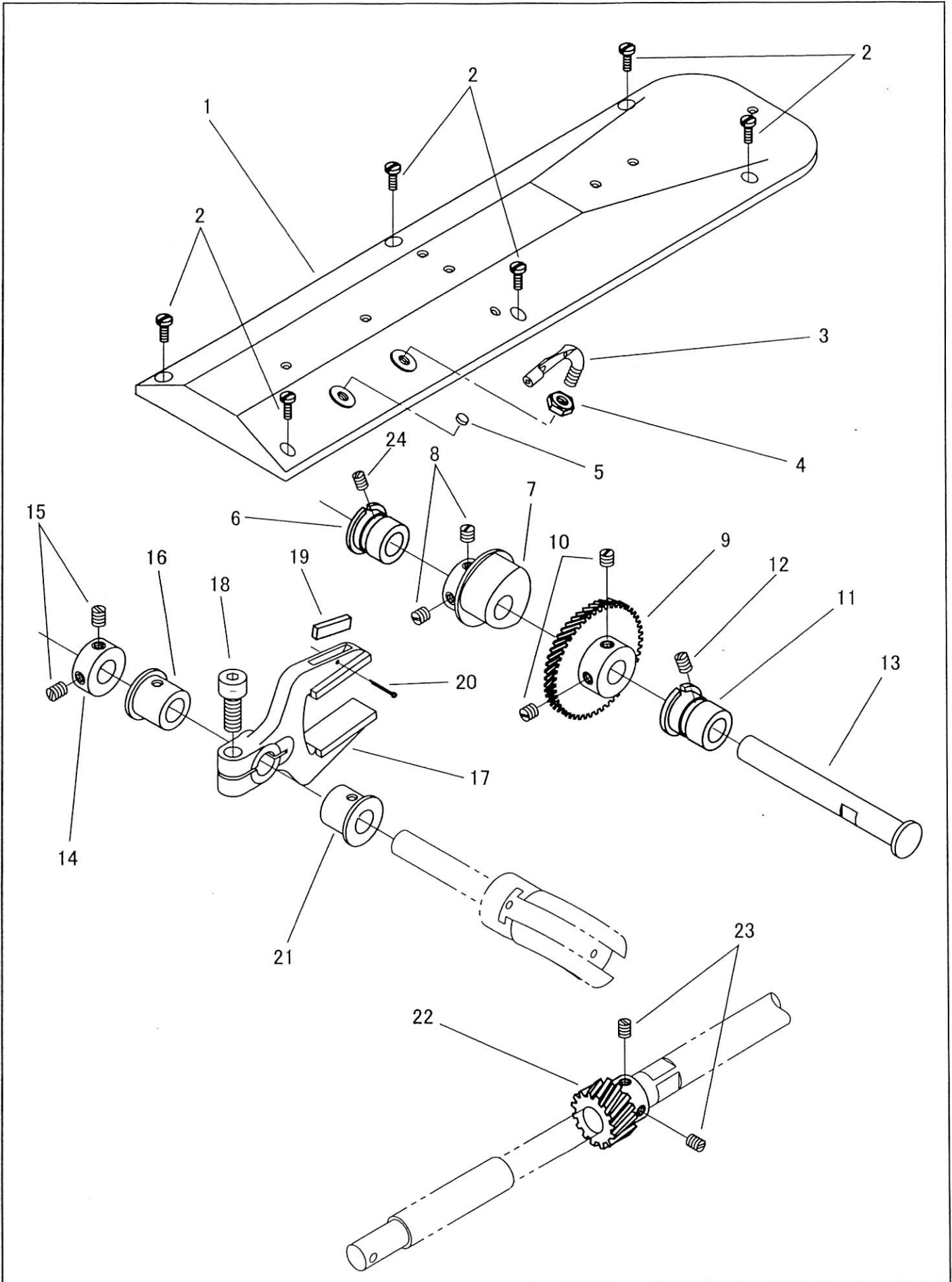

針振りギヤー、上板/ZIGZAG GEAR, ARM TOP COVER
SKZ-6BR

No.	部品番号 PARTS NO.	GBR	個数 QTY	品名	DESCRIPTION
1	1805	*	1	上板	ARM TOP COVER
2	15007	*	6	上板止めねじ	SCREW SM9/64X40
3	11006	*	1	上板糸掛	ARM TOP COVER THREAD GUIDE
4	13076-02	*	1	上板糸掛ナット	NUT SM7/32X32
5	15038	*	1	上板ゴム栓	FACE PLATE RUBBER
6	1961	*	1	針振りギヤー軸メタル(後)	ZIGZAG SHAFT BUSHING (BACK)
7	1834	*	1	針振りカム	ZIGZAG ECCENTRIC
8	10766	*	2	針振りカム止めねじ	SCREW SM1/4X32 L=7
9	1830-A	*	1	針振り大ギヤー	ZIGZAG GEAR (LARGE)
10	10766	*	2	針振り大ギヤー止めねじ	SCREW SM1/4X32 L=7
11	1960	*	1	針振りギヤー軸メタル(前)	ZIGZAG SHAFT BUSHING (FRONT)
12	8009	*	1	針振りギヤー軸メタル(前)止めねじ	SCREW SM15/64X28 L=7.5
13	1831	*	1	針振りギヤー軸	ZIGZAG GEAR SHAFT
14	1838	*	1	針振り軸カラー	ZIGZAG ECCENTRIC SHAFT COLLAR
15	10766	*	2	針振り軸カラー止めねじ	SCREW SM1/4X32 L=7
16	1833	*	1	針振り軸メタル(後)	ZIGZAG ECCENTRIC SHAFT BUSHING (BACK)
17	1835	*	1	針振りニ又	ZIGZAG ECCENTRIC FORK
18	27181	*	1	針振りニ又締めねじ	SCREW M8X1.25
19	17026	*	1	針振りニ又フェルト	OIL FELT
20	10620	*	1	フェルト止め割りピン	COTTER PIN
21	1833	*	1	針振り軸メタル(前)	ZIGZAG ECCENTRIC SHAFT BUSHING (FRONT)
22	1829-A	*	1	針振り小ギヤー	ZIGZAG GEAR (SMALL)
23	10766	*	2	針振り小ギヤー止めねじ	SCREW SM1/4X32 L=7
24	2067	*	1	針振りギヤー軸メタル(後)止めねじ	SCREW SM11/64X40 L=6

針振りギヤー、上板/ZIGZAG GEAR, ARM TOP COVER
 SKZ-6BR-3, SKZ-6BR-4

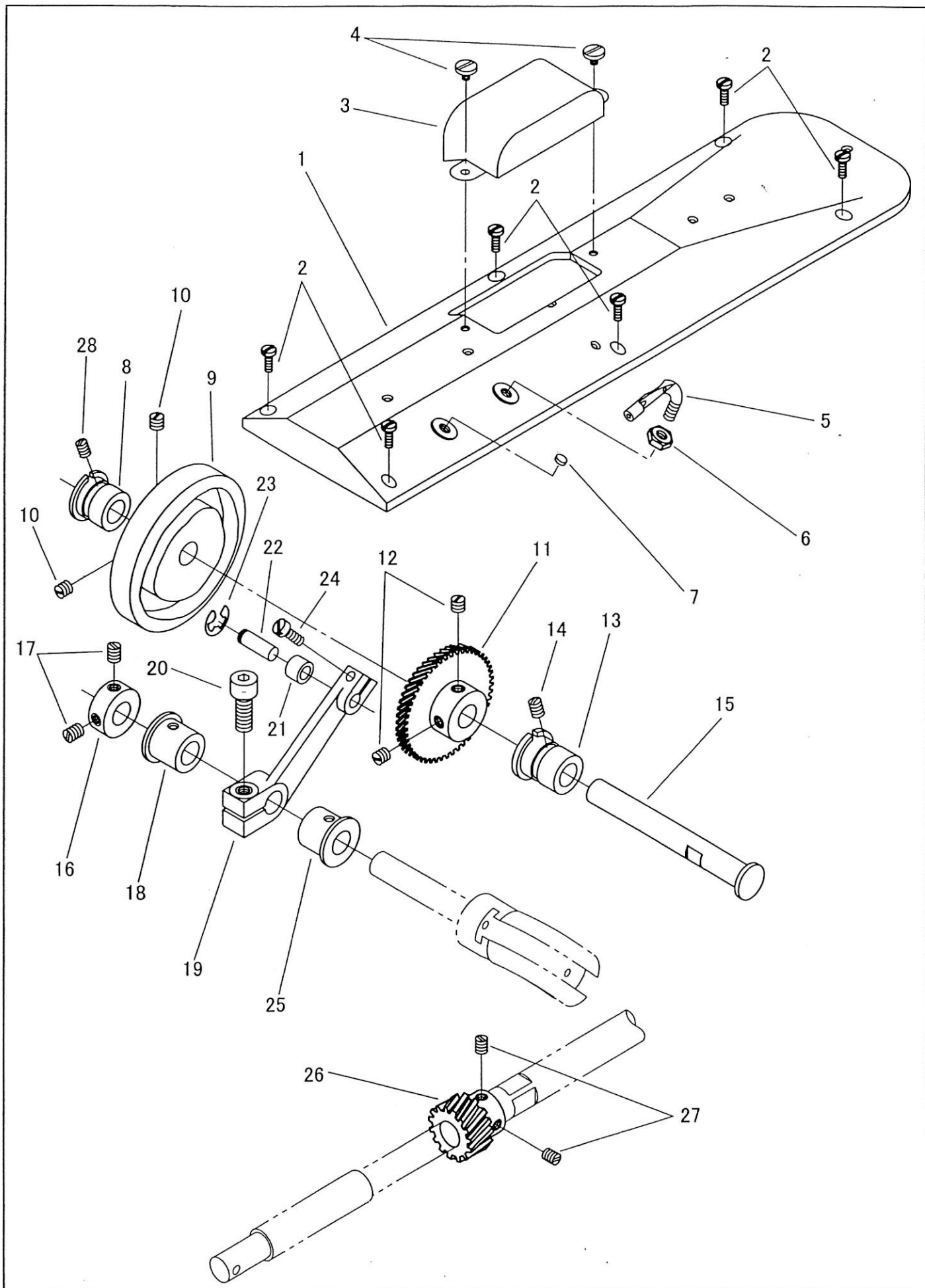

針振りギヤー、上板/ZIGZAG GEAR, ARM TOP COVER
SKZ-6BR-3, SKZ-6BR-4

No.	部品番号 PARTS NO.	6BR-3	6BR-4	個数 QTY	品名	DESCRIPTION
1	1954	*	*	1	上板	ARM TOP COVER
2	15007	*	*	6	上板止めねじ	SCREW SM9/64X40
3	1955	*	*	1	上板カバー	AUXILIARY ARM TOP COVER
4	2031	*	*	2	上板カバー止めねじ	SCREW SM9/64X40 L=5
5	11006	*	*	1	上板糸掛	ARM TOP COVER THREAD GUIDE
6	13076-02	*	*	1	上板糸掛ナット	NUT SM7/32X32
7	15038	*	*	1	上板ゴム栓	FACE PLATE RUBBER
8	1961	*	*	1	針振りギヤー軸メタル(後)	ZIGZAG SHAFT BUSHING (BACK)
9	1951	*	-	1	針振りカム	ZIGZAG ECCENTRIC
9	1951-A	-	*	1	針振りカム	ZIGZAG ECCENTRIC
10	10639	*	-	2	針振りカム止めねじ	SCREW SM1/4X32 L=8
10	21144	-	*	2	針振りカム止めねじ	SCREW SM1/4X28 L=9.5
11	1956	*	-	1	針振り大ギヤー	ZIGZAG GEAR (LARGE)
11	1956-A	-	*	1	針振り大ギヤー	ZIGZAG GEAR (LARGE)
12	10766	*	*	2	針振り大ギヤー止めねじ	SCREW SM1/4X32 L=7
13	1960	*	*	1	針振りギヤー軸メタル(前)	ZIGZAG SHAFT BUSHING (FRONT)
14	8009	*	*	1	針振りギヤー軸メタル(前)止めねじ	SCREW SM15/64X28 L=7.5
15	1831	*	*	1	針振りギヤー軸	ZIGZAG GEAR SHAFT
16	1838	*	*	1	針振り軸カラー	ZIGZAG ECCENTRIC SHAFT COLLAR
17	10766	*	*	2	針振り軸カラー止めねじ	SCREW SM1/4X32 L=7
18	1833	*	*	1	針振り軸メタル(後)	ZIGZAG ECCENTRIC SHAFT BUSHING (BACK)
19	1952	*	*	1	針振り連結	ZIGZAG ECCENTRIC CONNECTION
20	27181	*	*	1	針振り連結締めねじ	SCREW M8X1.25
21	1959	*	*	1	針振りローラー	ZIGZAG ECCENTRIC CONNECTION ROLLER
22	1953	*	*	1	針振りローラーピン	ZIGZAG ECCENTRIC CONNECTION ROLLER PIN
23	4839	*	*	1	ローラー止め輪	RETAINING RING: E TYPE
24	6323	*	*	1	針振りローラーピン締めねじ	SCREW SM3/16X32 L=14.5
25	1833	*	*	1	針振り軸メタル(前)	ZIGZAG ECCENTRIC SHAFT BUSHING (FRONT)
26	1957	*	-	1	針振り小ギヤー	ZIGZAG GEAR (SMALL)
26	1957-A	-	*	1	針振り小ギヤー	ZIGZAG GEAR (SMALL)
27	10766	*	*	2	針振り小ギヤー止めねじ	SCREW SM1/4X32 L=7
28	2067	*	*	1	針振りギヤー軸メタル(後)止めねじ	SCREW SM11/64X40 L=6

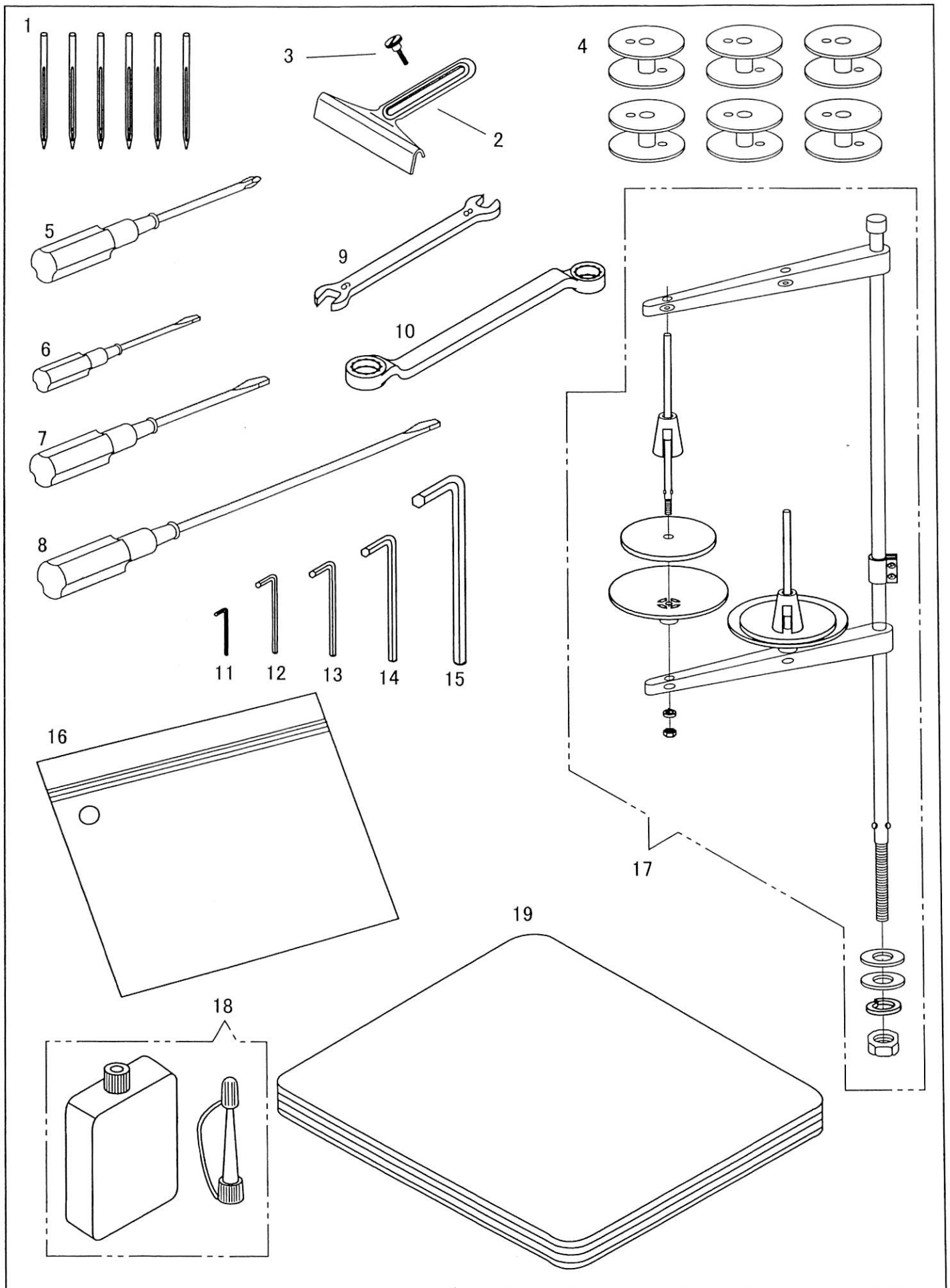

付属品1/ACCESSORIES 1

No.	部品番号 PARTS NO.	6BR	6BR-3	6BR-4	個数 QTY	品名	DESCRIPTION
1	N1225	*	*	*	6	針DDXH14#25	NEEDLE DDXH14 #25
2	6050	*	*	*	1	定規	CLOTH EDGE GUIDE
3	7047	*	*	*	1	定規止めねじ	SCREW SM9/64X40
4	1441	*	*	*	6	ボビン	BOBBIN
5	19473	*	*	*	1	十字ドライバー	SCREW DRIVER (CROSS TYPE)
6	8121	*	*	*	1	ドライバー(小)	SCREW DRIVER (SMALL)
7	8120	*	*	*	1	ドライバー(中)	SCREW DRIVER (MIDDLE)
8	8118	*	*	*	1	ドライバー(大)	SCREW DRIVER (LARGE)
9	4202	*	*	*	1	スパナ	SPANNER (9 X 8)
10	19462	*	*	*	1	メガネレンチ	DOUBLE HEAD WRENCH
11	1872	*	*	*	1	六角レンチ(1.5MM)	HEXAGONAL WRENCH (1.5MM)
12	19457	*	*	*	1	六角レンチ(2.5MM)	HEXAGONAL WRENCH (2.5MM)
13	19458	*	*	*	1	六角レンチ(3MM)	HEXAGONAL WRENCH (3MM)
14	19459	*	*	*	1	六角レンチ(4MM)	HEXAGONAL WRENCH (4MM)
15	1871	*	*	*	1	六角レンチ(6MM)	HEXAGONAL WRENCH (6MM)
16	8132-A	*	*	*	1	部品袋	ACCESSORY BAG
17	35254	*	*	*	1	糸立セット	THREAD STAND COMPLETE
18	8123	*	*	*	1	油	OILER
19	8124	*	*	*	1	ビニールカバー(大)	VINYL COVER

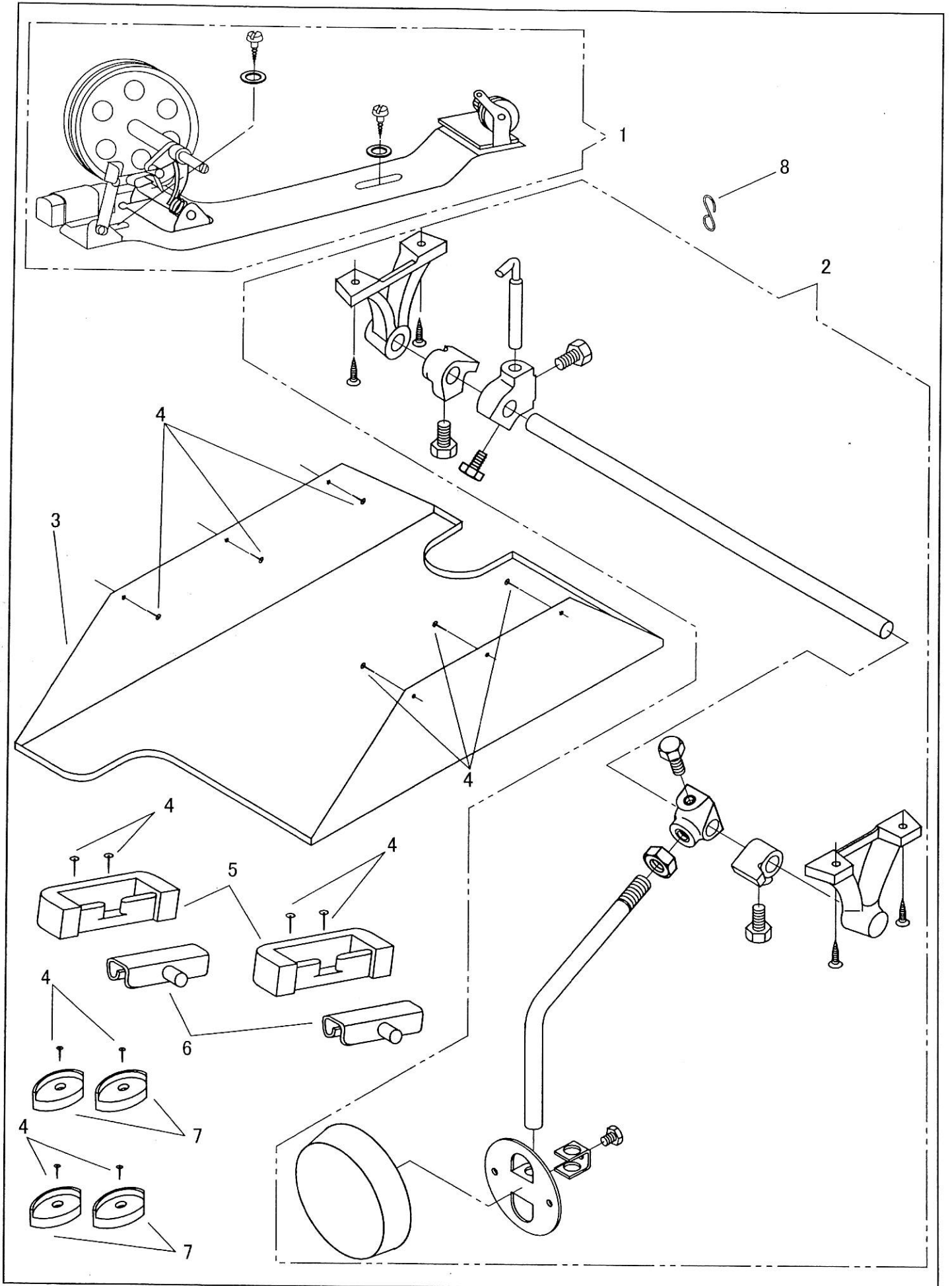

付属品2/ACCESSORIES 2



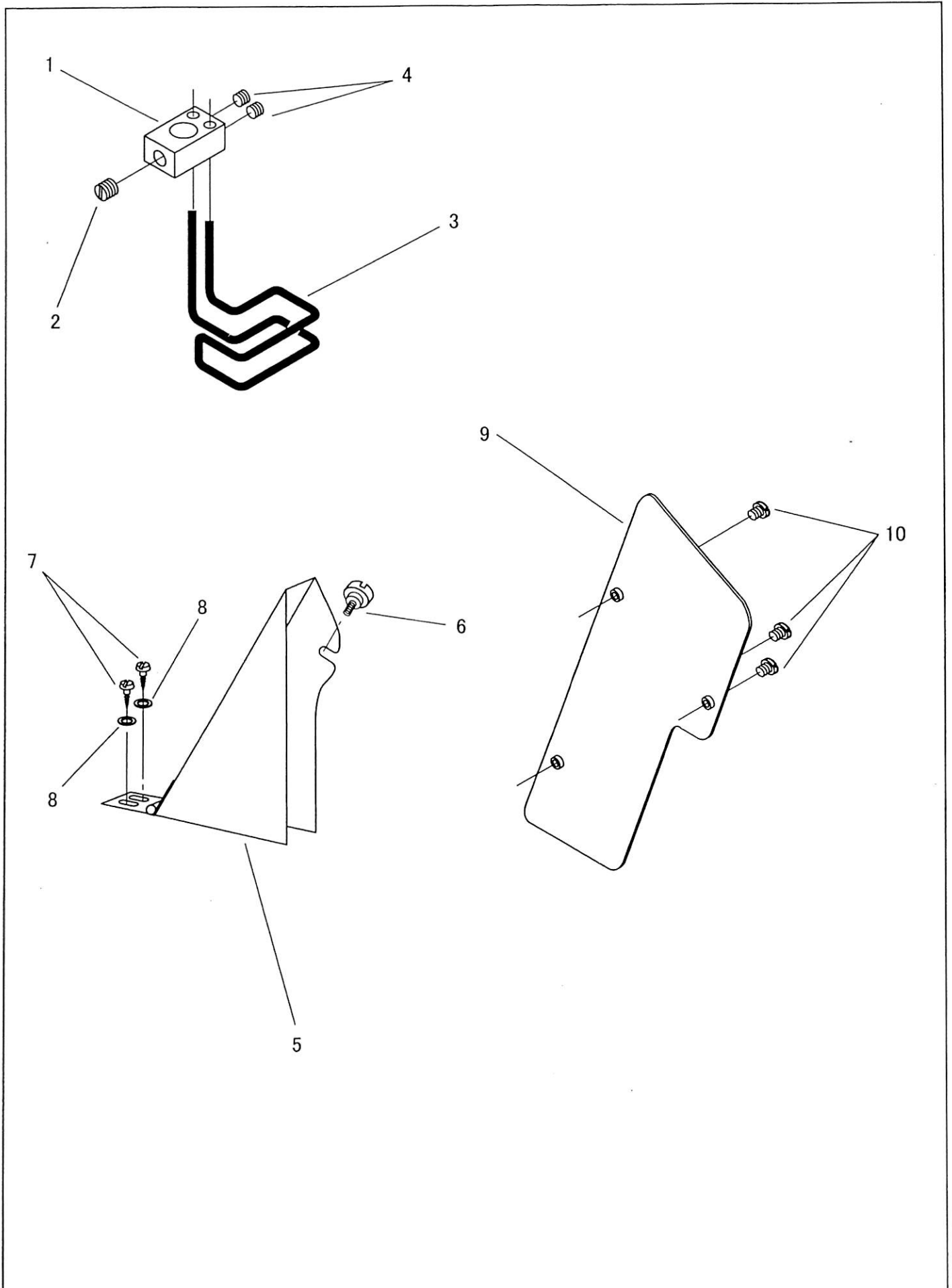

No.	部品番号 PARTS NO.	6BR	6BR-3	6BR-4	個数 QTY	品名	DESCRIPTION
1	1440	*	*	*	1	糸巻セット	BOBBIN WINDER COMPLETE
2	1552	*	*	*	1	ひざ上げセット	KNEE LIFTER COMPLETE
3	1553	*	*	*	1	油受	OIL PAN
4	6055	*	*	*	14	止釘	NAIL
5	11886	*	*	*	2	ヒンジ受ゴム	HINGE RUBBER CUSHION
6	11885	*	*	*	2	ヒンジ	HINGE CONNECTION
7	11887	*	*	*	4	コーナーゴム	CORNER RUBBER CUSHION
8	104879	*	*	*	1	フック	HOOK





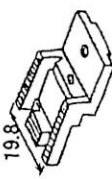

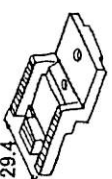
別売品/OPTION

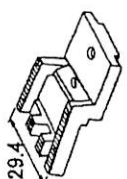
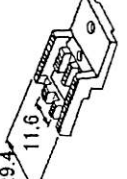
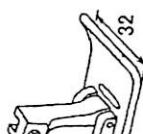
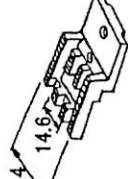
No.	部品番号 PARTS NO.	6BR	6BR-3	6BR-4	個数 QTY	品名	DESCRIPTION
1	35245	*	*	*	1	フィンガーガード取付台	FINGER GUARD BASE
2	8097	*	*	*	1	フィンガーガード取付台止めねじ	SCREW SM15/64X28 L=5
3	1897	*	*	*	1	フィンガーガード	FINGER GUARD
4	8103	*	*	*	2	フィンガーガード止めねじ	SCREW SM11/64X40 L=3.5
5	1458	*	*	*	1	補助ベルトガード(組)	AUXILIARY BELT GUARD COMPLETE
6	11830	*	*	*	1	補助ベルトガード止めねじ	SCREW 9/64X40
7	15081	*	*	*	2	補助ベルトガード木ねじ	WOOD SCREW
8	16287	*	*	*	2	補助ベルトガード木ねじワッシャー	WASHER
9	1996	*	*	*	1	ベルトガード補助板	BELT GUARD AUXILIARY PLATE
10	6339	*	*	*	3	ベルトガード補助板止めねじ	SCREW SM1/8X44 L=4

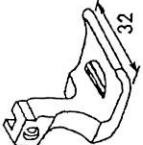
ゲージ表/TABLE OF GAUGE PARTS

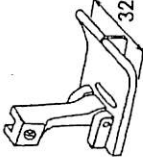
	針板 THROTE PLATE	送り歯 FEED DOG	自由押え HINGED PRESSER FOOT
3列 3 ROW	巾狭 NARROW	 19.8 1881-A	 18 1867-AC
	巾広 WIDE	 29.4 1881	 32 1865C
4列 4 ROW	4枚歯 4 TEETH	 29.4 1882	
	6枚歯 巾狭 6 TEETH NARROW	 29.4 11.6 1882	 32 1893-AC
	6枚歯 巾広 6 TEETH WIDE	 29.4 14.9 1880	

固定押え SOLID PRESSER FOOT	固定押え(溝付) PIPING FOOT	自由押え(ガイド付) HINGED FOOT W/ GUIDE	割りガイド(別売り品) GUIDE PLATE (OPTION)
 1894	 A (mm) NO. 11.0 1885 8.2 1886 6.6 1887 5.2 1888 6.2 1889 9.4 1890 4.6 1891 7.2 1892	 32 1893-BC	 1896 1876に取り付け可 SUITABLE FOR 1876 37112

SEIKO SEWING MACHINE CO., LTD.

2-13-6 Sakaecho, Funabashi-shi Chiba Prefecture, 273-0018, Japan

TEL: 81-47-420-3561 (Overseas dept.)

FAX: 81-47-420-3560

E-mail: export@seiko-sewing.co.jp

<http://www.seiko-sewing.co.jp/>

Parts No. PB29600(0108)

Rev. 2