

針板・下送り軸/THROAT PLATE, LOWER FEED ROCK SHAFT

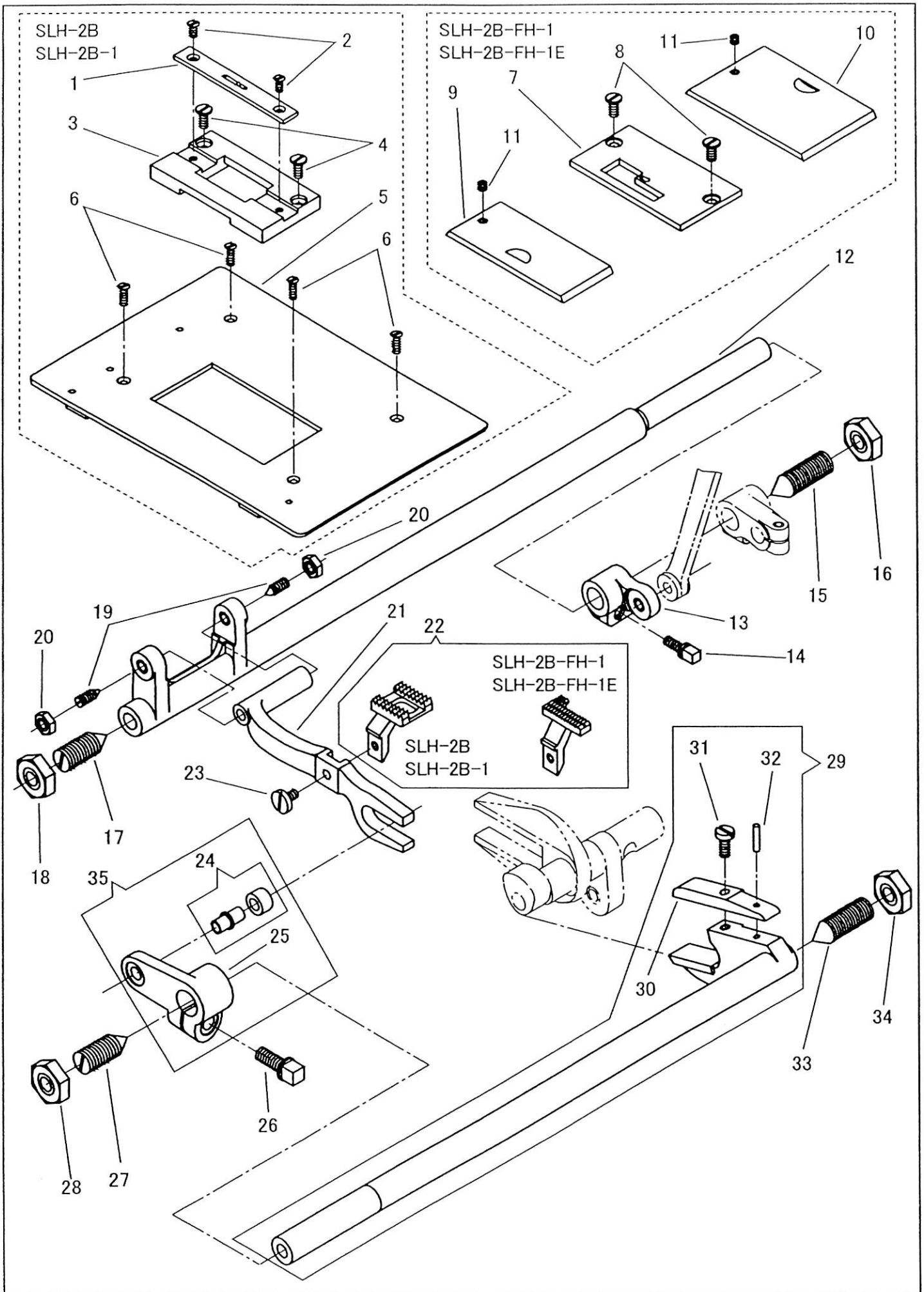

針板・下送り軸/THROAT PLATE, LOWER FEED ROCK SHAFT

No.	部品番号 PARTS NO.	2B	2B-1	2B-FH-1	2B-FH-1E	個数 QTY	品名	DESCRIPTION
1	35190-AB	*	*	-	-	1	針板	THROAT PLATE
2	35191	*	*	-	-	2	針板止めねじ	SCREW 3/16X32
3	35192	*	*	-	-	1	針板台	THROAT PLATE BODY
4	35193	*	*	-	-	2	針板台止めねじ	SCREW 15/64X28
5	35194	*	*	-	-	1	針板台上板	CLOTH PLATE
6	35195	*	*	-	-	4	針板台上板止めねじ	SCREW 3/16X32 L=14.5
7	35175	-	-	*	-	1	針板	THROAT PLATE
7	35175-E	-	-	-	*	1	針板	THROAT PLATE
8	35193	-	-	*	*	2	針板止めねじ	SCREW 15/64X28
9	35177	-	-	*	*	1	角板(左)	BED SLIDE (LEFT)
10	35178	-	-	*	*	1	角板(右)	BED SLIDE (RIGHT)
11	101133	-	-	*	*	2	角板止めねじ	SCREW 15/64X28 L=3.8
12	35184	*	*	*	*	1	下送り軸	LOWER FEED ROCK SHAFT
13	35182	*	*	*	*	1	下送り軸クランク	LOWER FEED ROCK SHAFT CRANK
14	35183	*	*	*	*	1	下送り軸クランク締めねじ	SCREW 1/4X24UNE
15	35185	*	*	*	*	1	下送り軸大ペンねじ(長)	SCREW CENTER 5/8X16UN (LONG)
16	35187	*	*	*	*	1	下送り軸大ペンナット	NUT 5/8X16UN
17	35186	*	*	*	*	1	下送り軸大ペンねじ(短)	SCREW CENTER 5/8X16UN (SHORT)
18	35187	*	*	*	*	1	下送り軸大ペンナット	NUT 5/8X16UN
19	6027-01	*	*	*	*	2	送り腕ペンねじ	SCREW 3/8X28
20	6027-02	*	*	*	*	2	送り腕ペンねじナット	NUT 3/8X28
21	35188	*	*	*	*	1	送り腕	FEED BAR
22	35176	-	-	*	*	1	送り歯	FEED DOG
22	35189	*	*	-	-	1	送り歯	FEED DOG
23	1368	*	*	*	*	1	送り歯止めねじ	SCREW 1/4X24 L=11
24	35235	*	*	*	*	1	上下送り軸クランク丸玉	ROLLER & STUD
25	35233	*	*	*	*	1	上下送り軸クランク	FEED LIFTING ROCK SHAFT CRANK
26	35234	*	*	*	*	1	上下送り軸クランク締めねじ	SCREW 3/8X18
27	35186	*	*	*	*	1	上下送り軸大ペンねじ(短)	SCREW CENTER 5/8X16UN (SHORT)
28	35187	*	*	*	*	1	上下送り軸大ペンねじナット	NUT 5/8X16UN
29	35232C	*	*	*	*	1	上下送り軸	FEED LIFTING ROCK SHAFT COMPLETE
30	35232-01	*	*	*	*	1	上下送り軸補助板	WEARYING BLOCK
31	35223	*	*	*	*	1	上下送り軸止めねじ	SCREW 1/4X24 L=16
32	50174	*	*	*	*	1	上下送り軸テーパピン	TAPER PIN
33	35185	*	*	*	*	1	上下送り軸大ペンねじ(長)	SCREW CENTER 5/8X16UN (LONG)
34	35187	*	*	*	*	1	上下送り軸大ペンねじナット	NUT 5/8X16UN
35	35233C	*	*	*	*	1	上下送り軸クランク(組)	FEED LIFTING ROCK SHAFT CRANK COMPLETE

糸調子部品/PARTS FOR THREAD TENSION

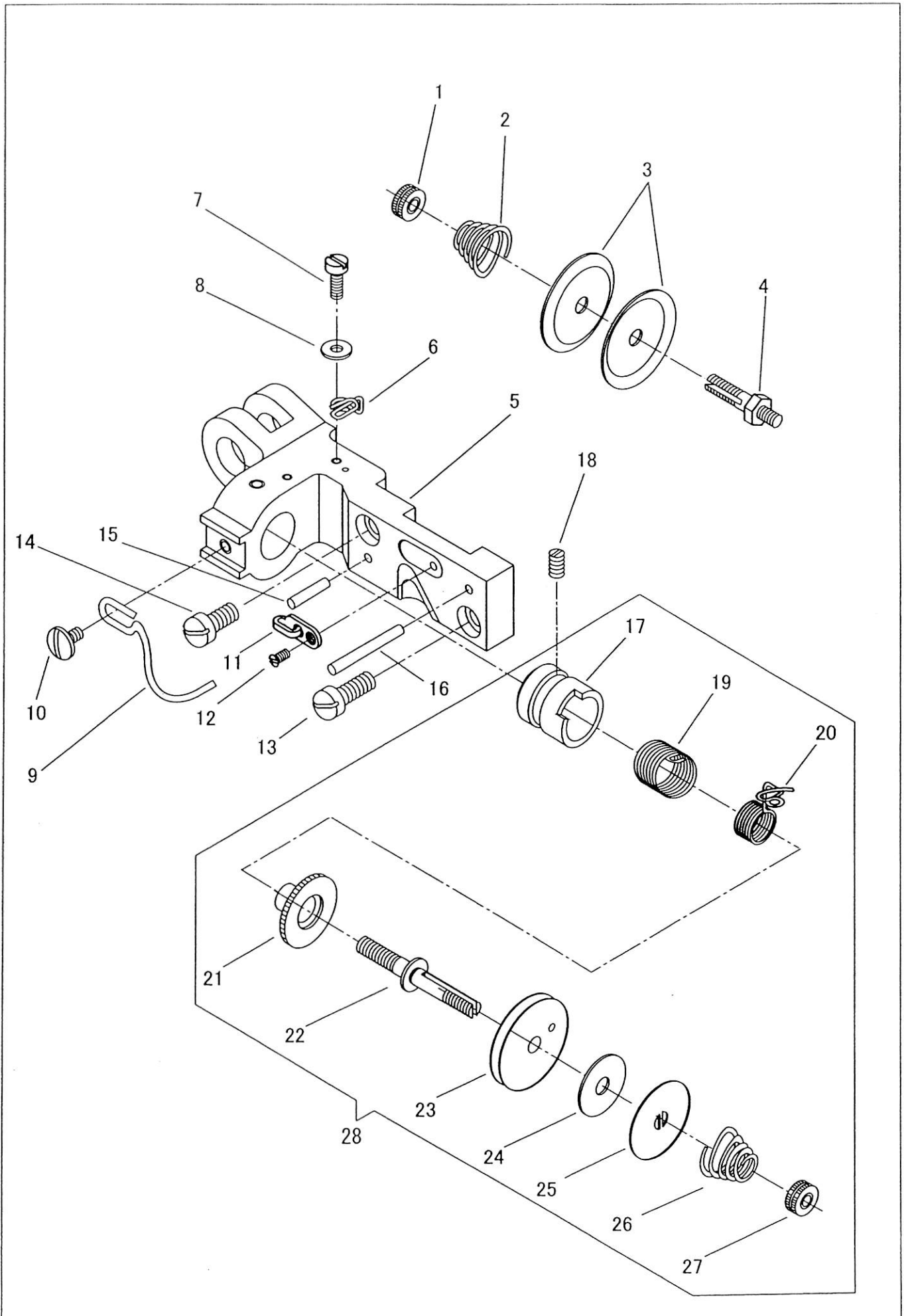

糸調子部品/PARTS FOR THREAD TENSION

No.	部品番号 PARTS NO.	2B	2B-1	2B-FH-1	2B-FH-1E	個数 QTY	品名	DESCRIPTION
1	8079	*	*	*	*	1	小調子棒ナット	TENSION THUMB NUT 1/4X40
2	1422	*	*	*	*	1	小調子棒スプリング	TENSION SPRING
3	1423	*	*	*	*	2	小調子棒皿	TENSION DISC
4	4171	*	*	*	*	1	小調子棒	TENSION STUD (POST)
5	35087	*	*	*	*	1	上送りニ又台	CONNECTING BRACKET
6	35159	*	*	*	*	1	糸掛(中)	THREAD GUIDE (MIDDLE)
7	6025	*	*	*	*	1	糸掛(中)止めねじ	SCREW 11/64X40 L=12
8	11142	*	*	*	*	1	糸掛(中)ワッシャー	WASHER
9	35166	*	*	*	*	1	大糸掛	LARGE THREAD GUIDE
10	18417	*	*	*	*	1	大糸掛止めねじ	SCREW 4.5X32 L=8
11	10683	*	*	*	*	1	糸掛(下)	THREAD GUIDE (LOWER)
12	10685	*	*	*	*	1	糸掛(下)止めねじ	SCREW 3.4X36
13	10519	*	*	*	*	1	上送りニ又台止めねじ(長)	SCREW 6.75X24 L=17.5
14	35088	*	*	*	*	1	上送りニ又台止めねじ(短)	SCREW 6.75X24 L=15
15	35089-01	*	*	*	*	1	上送りニ又台ノックピン	PIN 4X22L
16	35089-02	*	*	*	*	1	上送りニ又台ノックピン	PIN 4X35L
17	1414	*	*	*	*	1	糸調子臼	TENSION REGULATOR
18	10581	*	*	*	*	1	糸調子臼止めねじ	SCREW 7/32X32 L=7
19	1417	*	*	*	*	1	糸取り補助スプリング	REGULATING SPRING
20	35161	*	*	*	*	1	糸取りスプリング	THREAD TAKE-UP SPRING
21	1418	*	*	*	*	1	糸取りスプリング調節	THREAD TAKE-UP SPRING ADJUSTING SLEEVE
22	35160	*	*	*	*	1	糸調子棒	THREAD CONTROLLER STUD
23	35162	*	*	*	*	1	糸調子皿	TENSION DISC
24	35164	*	*	*	*	1	糸調子皮	TENSION DISC LEATHER
25	35163	*	*	*	*	1	糸調子丸一皿	TENSION DISC WASHER
26	35165	*	*	*	*	1	渦巻スプリング	TENSION RELEASE SPRING
27	8079	*	*	*	*	1	糸調子ナット	TENSION THUMB NUT 1/4X40
28	35160C	*	*	*	*	1	糸調子棒(組)	THREAD CONTROLLER STUD COMP.

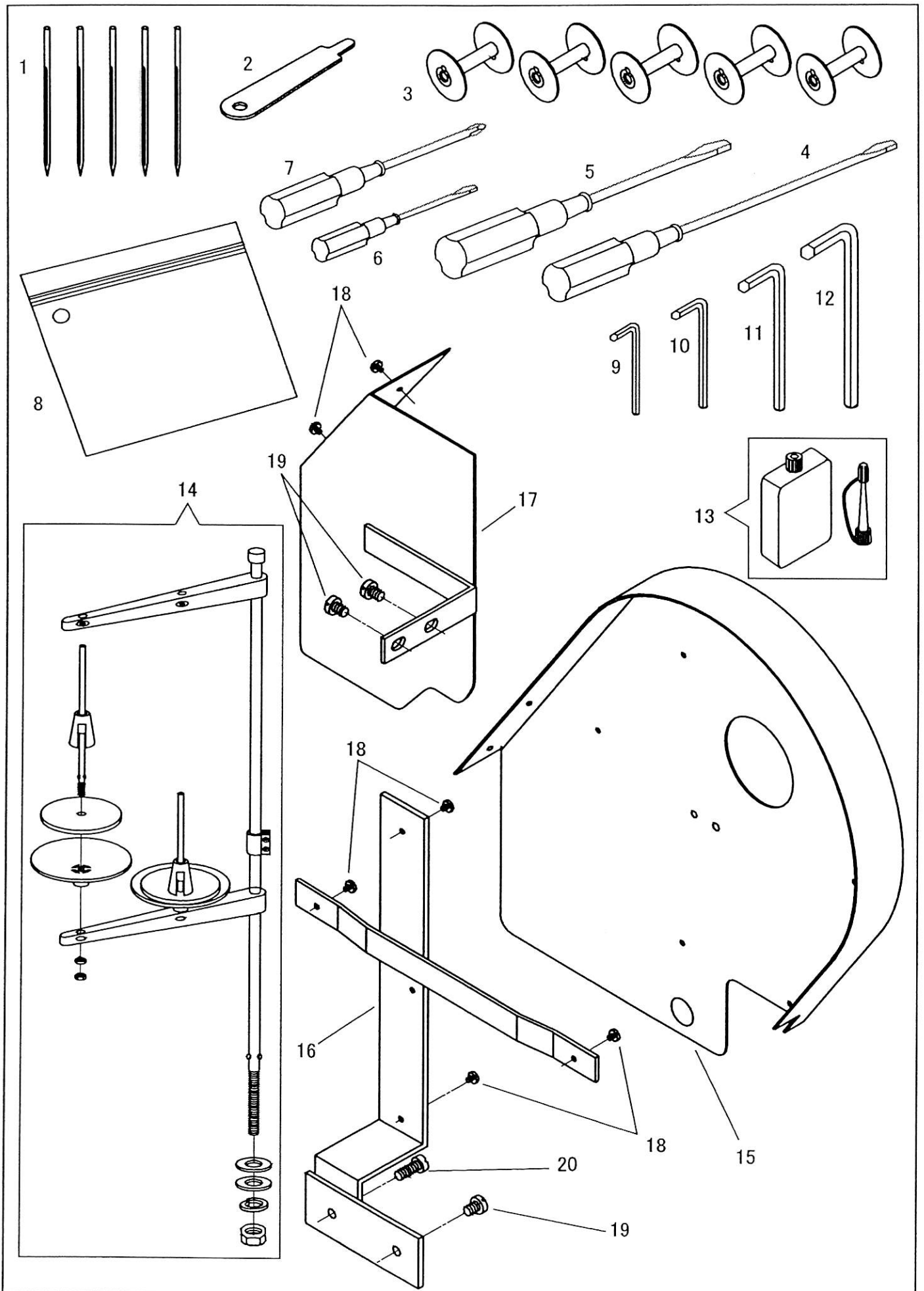

付属品1/ACCESSORIES 1

No.	部品番号 PARTS NO.	2B	2B-1	2B-FH-1	2B-FH-1E	個数 QTY	品名	DESCRIPTION
1	N0925	*	*	*	*	5	針	NEEDLE 1000 #250
2	35225	*	*	*	*	1	シリンダー開閉板	SHUTTLE CYLINDER OPENER
3	35226	*	*	*	*	5	ボビン	BOBBIN
4	8118	*	*	*	*	1	ドライバー(大)	SCREW DRIVER (LARGE)
5	8120	*	*	*	*	1	ドライバー(中)	SCREW DRIVER (MIDDLE)
6	8121	*	*	*	*	1	ドライバー(小)	SCREW DRIVER (SMALL)
7	19473	*	*	*	*	1	十字ドライバー	SCREW DRIVER (CROSS TYPE)
8	8132-B	*	*	*	*	1	部品袋	ACCESSORY BAG
9	19457	*	*	*	*	1	六角レンチ(2.5mm)	HEXAGONAL WRENCH (2.5MM)
10	19458	*	*	*	*	1	六角レンチ(3mm)	HEXAGONAL WRENCH (3MM)
11	19459	*	*	*	*	1	六角レンチ(4mm)	HEXAGONAL WRENCH (4MM)
12	19460	*	*	*	*	1	六角レンチ(5mm)	HEXAGONAL WRENCH (5MM)
13	8123	*	*	*	*	1	油(小)	OILER
14	35254	*	*	*	*	1	糸立セット	THREAD STAND COMPLETE
15	35494-01	*	*	*	*	1	ベルトガード本体(1)	BELT GUARD BODY (1)
16	35494-03	*	*	*	*	1	ベルトガード取付板	BELT GUARD STAY
17	35239-A	*	*	*	*	1	ベルトガード本体(2)	BELT GUARD BODY (2)
18	30046	*	*	*	*	6	ベルトガード本体止めねじ	SCREW M4X0.7 L=6
19	13005	*	*	*	*	3	ベルトガード取付板止めねじ(短)	SCREW 6.75X24 L=10
20	10519	*	*	*	*	1	ベルトガード取付板止めねじ(長)	SCREW 6.75X24 L=17.5

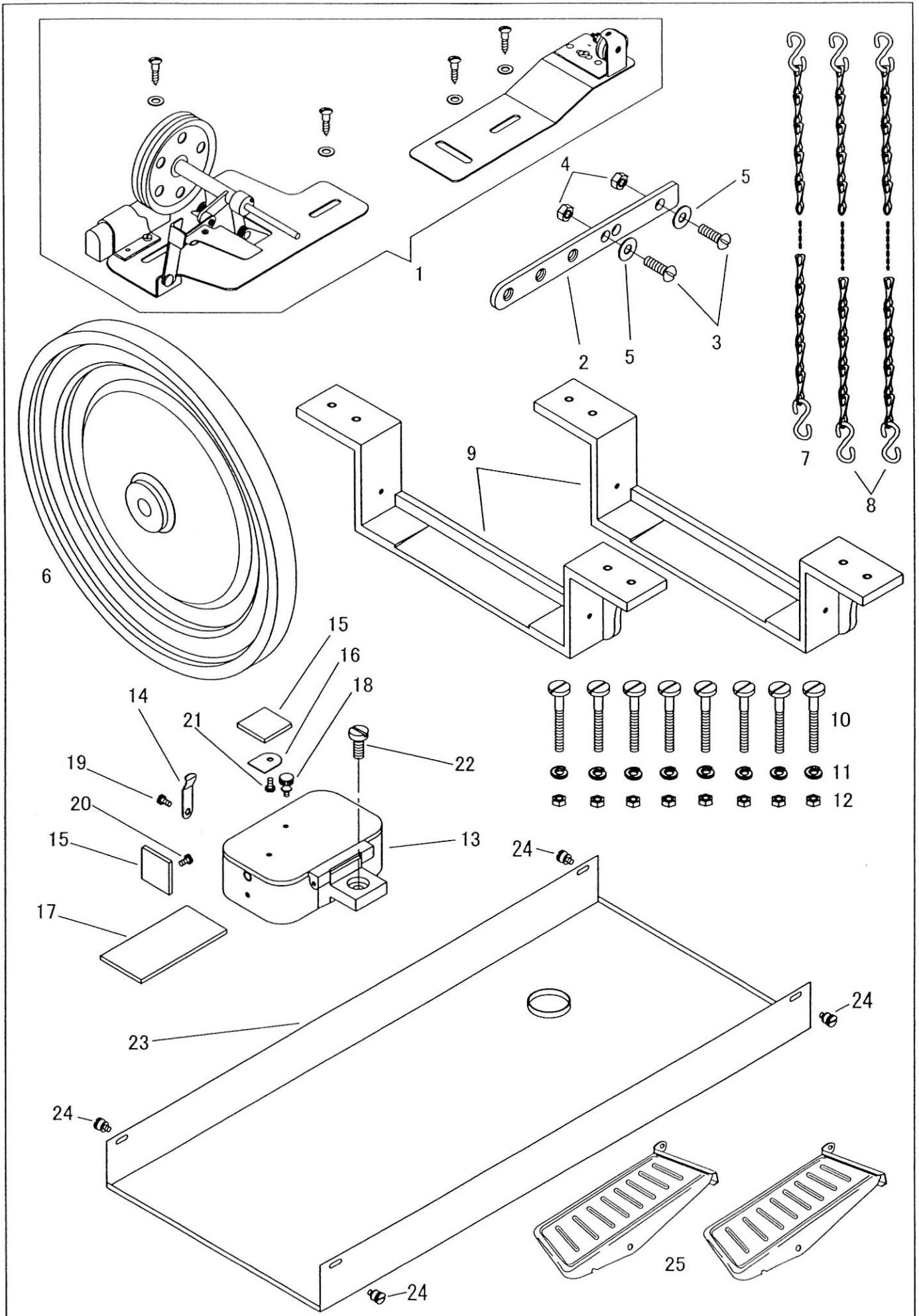

付属品2/ACCESSORIES 2

No.	部品番号					個数	品名	DESCRIPTION
	PARTS NO.	2B	2B-1	2B-FH-1	2B-FH-1E	QTY		
1	35255	*	*	*	*	1	糸巻セット	BOBBIN WINDER COMPLETE
2	11376	*	*	*	*	1	モーターレバー補助板	MOTOR LEVER EXTENSION
3	11377	*	*	*	*	2	モーターレバー補助板止めねじ	SCREW 1/4X32 L=19.5
4	8126-02	*	*	*	*	2	モーターレバー補助板止めねじナット	NUT 1/4X32
5	8126-03	*	*	*	*	2	モーターレバー補助板ワッシャー	WASHER
6	35007	*	*	*	*	1	プーリー	PULLEY
7	17082	*	*	*	*	1	くさり(500)	CHAIN (500)
8	13079	*	*	*	*	2	くさり(1000)	CHAIN (1000)
9	35240	*	*	*	*	2	ヒンジ	BED HINGE
10	35241	*	*	*	*	8	ヒンジ止めねじ	SCREW 5/16X18 L=65.5
11	0058	*	*	*	*	8	ヒンジ止めねじスプリングワッシャー	WASHER
12	0040	*	*	*	*	8	ヒンジ止めねじナット	NUT 5/16X18
13	35157C	*	*	*	*	1	オイルボックス(組)	OIL BOX COMPLETE
14	35157-04	*	*	*	*	1	スプリング板	OIL BOX COVER SPRING
15	35157-07	*	*	*	*	2	フェルト(小)	OIL BOX FELT (SMALL)
16	35157-08	*	*	*	*	1	フェルト押え板	OIL BOX FELT PLATE
17	35157-09	*	*	*	*	1	フェルト(大)	OIL BOX FELT (LARGE)
18	10699	*	*	*	*	1	開閉つまみ	THUMB SCREW 3.4X36
19	8100	*	*	*	*	1	スプリング板止めねじ	SCREW 9/64X40 L=6.5
20	8100	*	*	*	*	1	フェルト押え止めねじ	SCREW 9/64X40 L=6.5
21	8100	*	*	*	*	1	フェルト押え板止めねじ	SCREW 9/64X40 L=6.5
22	35223	*	*	*	*	1	オイルボックス止めねじ	SCREW 1/4X24 L=16
23	35242	*	*	*	*	1	油受け	OIL PAN
24	11570	*	*	*	*	4	油受け止めねじ	SCREW 13/64X32
25	13094	*	*	*	*	2	ペダルセット	PEDAL WITH STOP RINGS

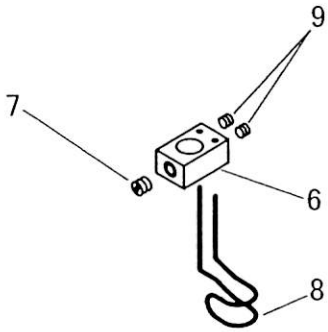
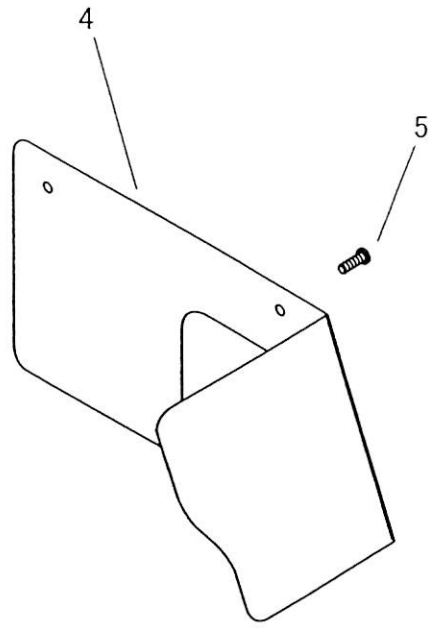
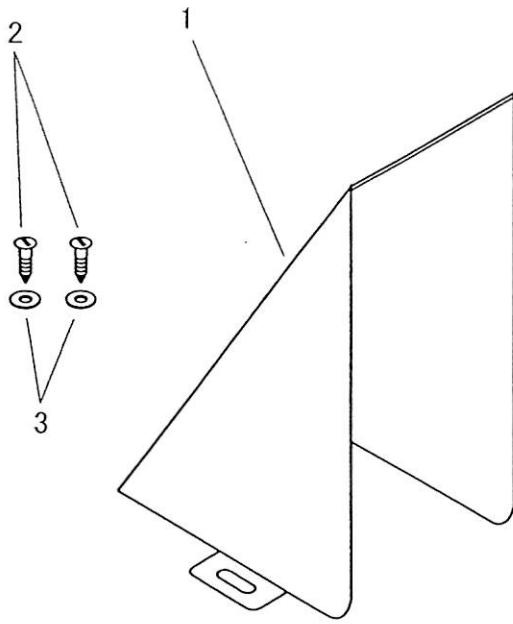

別売品/OPTION

No.	部品番号					個数	品名	DESCRIPTION
	PARTS NO.	2B	2B-1	2BLEH-1	2BLEH-1E	QTY		
1	35237	*	*	*	*	1	補助ベルトガード	AUXILIARY BELT GUARD
2	15081	*	*	*	*	2	補助ベルトガード木ねじ	WOOD SCREW
3	16287	*	*	*	*	2	補助ベルトガード木ねじワッシャー	WASHER
4	35238	*	*	*	*	1	補助ベルトガード(前)	AUXILIARY BELT GUARD (FRONT)
5	30046	*	*	*	*	1	補助ベルトガード(前)止めねじ	SCREW M4X0.7 L=6
6	35245	*	*	*	-	1	フィンガーガード取付台	FINGER GUARD BASE
6	35246	-	-	-	*	1	フィンガーガード取付台	FINGER GUARD BASE
7	8097	*	*	*	*	1	フィンガーガード取付台止めねじ	SCREW 15/64X28 L=5
8	35244	*	*	*	-	1	フィンガーガード	FINGER GUARD
8	28564	-	-	-	*	1	フィンガーガード	FINGER GUARD
9	8103	*	*	*	*	2	フィンガーガード止めねじ	SCREW 11/64X40 L=3.5

SEIKO SEWING MACHINE CO., LTD.

2-13-6 Sakaecho, Funabashi-shi Chiba Prefecture,
273-0018, Japan

TEL: 81-47-420-3561 (Overseas dept.)

FAX: 81-47-420-3560

E-mail: export@seiko-sewing.co.jp

<http://www.seiko-sewing.co.jp/>

セイコーミシン株式会社

〒273-0018 千葉県船橋市栄町2-13-6

TEL: 047-420-3561, IP電話: 050-3535-3491

FAX: 047-420-3560

E-mail: eigyo@seiko-sewing.co.jp

(国内営業)

Parts No. PB72100 (1015)

Rev. 4.3