

# HVP-70 series

AC Servo Motor for “SEIKO” machine



## Features

Simple and easy to use for “SEIKO” machines.

(Pre-setting the necessary parameters for “SEIKO” Models then only setting the machine code number when initial operation.)

Specification matched the “CE” Standard.

Without synchronizer(if damaged), motor working as Clutch motor and the backtack solenoid & auto-foot lifter still working.

Solenoid over current protected.

C300 operation panel with computer RS232C interface, the control box can program from computer.

Fully digital design, powerful parameter built-in for application.

With O.V. ,O.C. ,L.V. protection function and controlled by software.

With auto-running timer inside, easy to test. (Function no.135, 136, 137 & 138)

Can direct drive.

Easy to maintain through error cord display.

# HVP-70 series

## Dimension

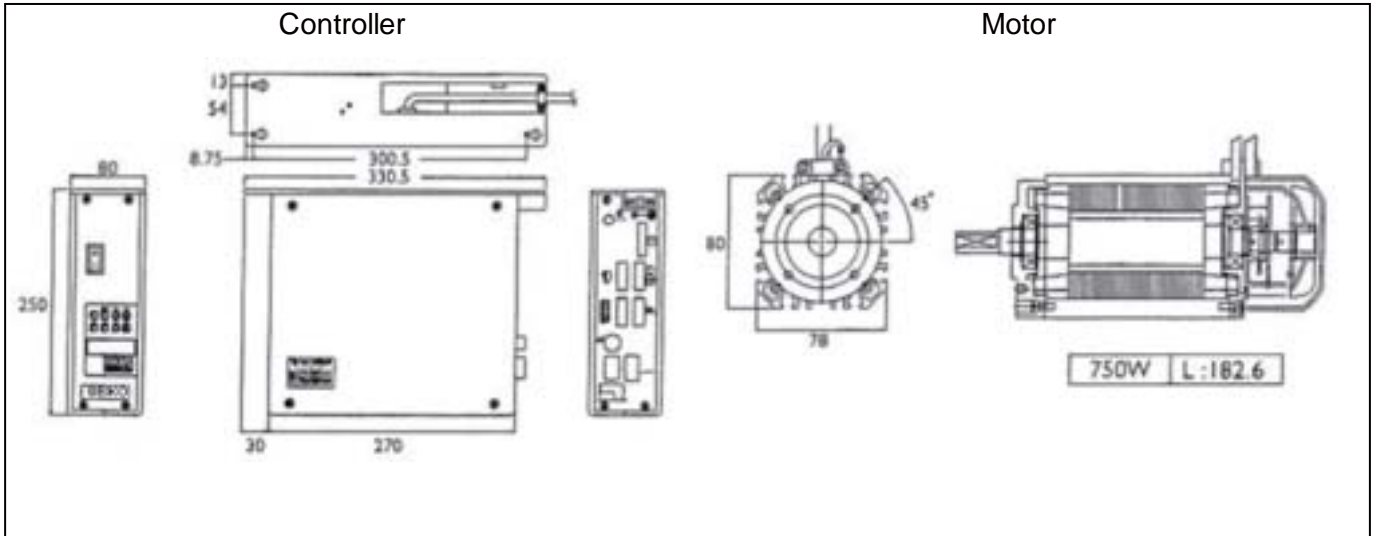

## Option Parts

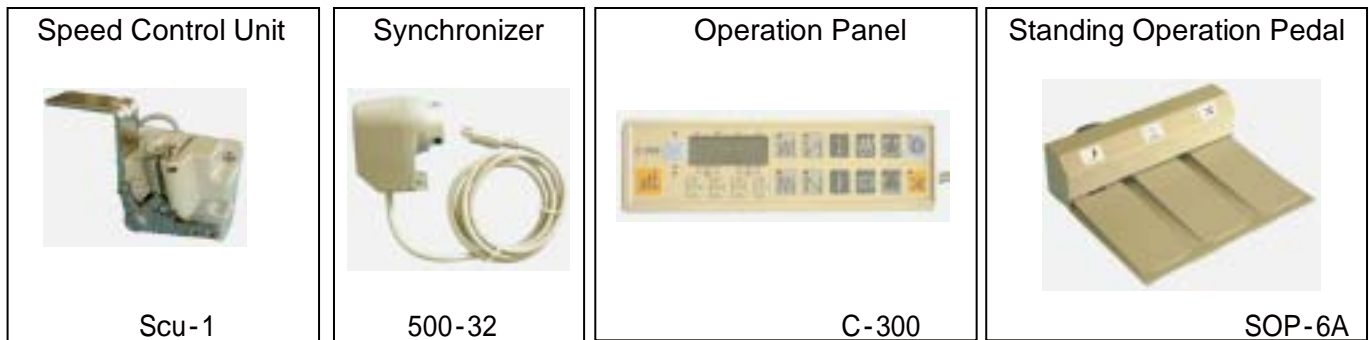

## Specification

Rated speed (r.p.m)	3,500	2,500
Rated torque (N·m)	2.05	2.86
Rated output (W)	750	
Power voltage range (V)	100-120 / 200-240	
Pulley size available (mm)	55-85	
Gross weight (Kg)	10.9	
Packing dimension (mm)	400L X 350W X 320H	

## Feature

- Needle up/down
- Slow start
- Presser foot lifter
- Trimmer
- Automatic backtacking
- Climbing device, dual stitching device
- Edge sensor input
- DC12V lamp output



### SEIKO SEWING MACHINE CO., LTD.

2-13-6, Sakaecho, Funabashi-shi  
Chiba Prefecture, 273-0018, Japan

Phone : +81-47-420-3561 (Overseas dept.)

Fax : +81-47-420-3560

E-mail : export@seiko-sewing.co.jp

<http://www.seiko-sewing.co.jp/>