

# JW two needle series

Two needle, Extra heavy duty, Extra long arm, Extra large vertical axis hook, Compound feed and walking foot, Lockstitch machines

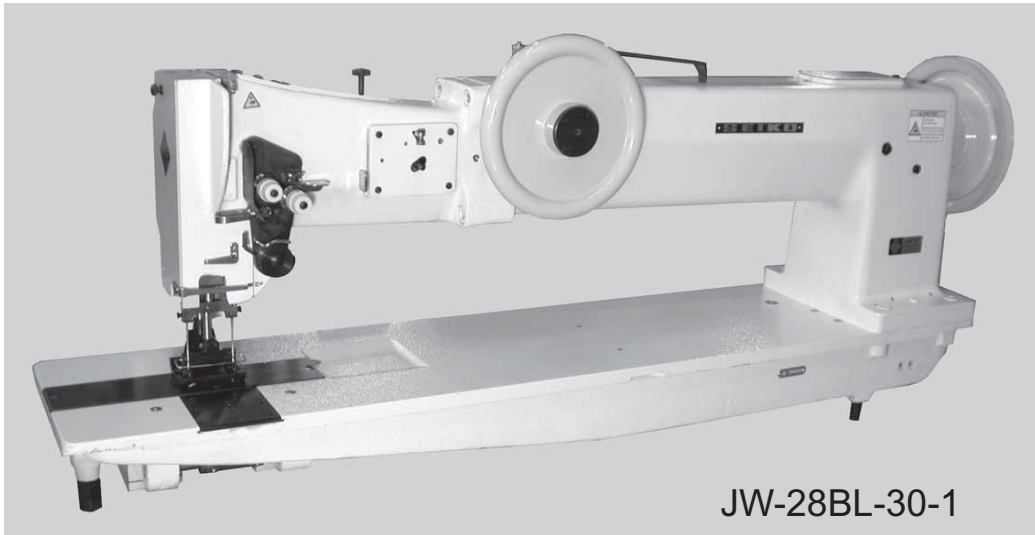

JW-28BL-30-1

## Variety

### JW-28BL-10

10 inch machine arm, reverse stitch

### JW-28BL-20-1

20 inch machine arm, reverse stitch

### JW-28BL-30-1

30 inch machine arm, reverse stitch

Auto thread trimmer



### JW-28BLC-20

20 inch machine arm, reverse stitch



### JW-28BLC-30

30 inch machine arm, reverse stitch



JW-28BL-10

10 inch machine arm



Clutch driven puller feed

## Applications

- For sewing extra heavy weight materials such as canvas, vinyl, leather, synthetics, and various coated, laminated and rubberized fabric.
- Suitable for sewing such as tents, tarps, awnings, truck covers, auto marine and furniture upholstery, field covers, fabric structures and heavy bulky products.

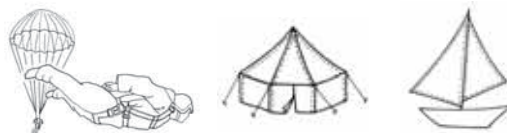

# JW two needle series

## Features

- Long and wide working space is suitable for sizable materials such as tents and sail clothes.
- Extra large vertical axis hook.
- Compound feed and walking foot mechanism assures even feeding of materials.
- Automatic hook lubrication.
- Safety clutch prevents the hook from being damaged.
- Reverse feed operated by foot pedal.
- Push button stitch regulator.
- Built-in bobbin winder. (except 10 inch model)
- Thread trimmer machine available. (except 10 inch)
- Front handwheel (30 inch model only) allows for easy positioning of the needle.
- Cloth puller available. Add suffix "R" when ordering.
- Automatic back tack(BT) and foot lift(FL) available.
- Single needle machines available as standard.

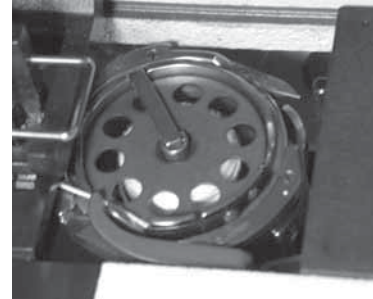

Extra large vertical axis hook

## Specifications (JW-□□)

Variety	28BL-10	28BL-20-1	28BL-30-1	28BLC-20	28BLC-30
Number of needle	Two needle				
Max. sewing speed	1,200 s.p.m.				
Max. stitch length	25/64" (10 mm)				
Clearance under presser foot	by knee		29/32" (23 mm)		
	by hand		25/32" (20 mm)		
Needle bar stroke	1-27/32" (46.8 mm)				
Needle(standard)	DYx3 (#24) , 794 (#180)				
Thread	#5 (standard)				
Hook	Extra large vertical axis hook				
Amount of lift of walking foot	15/64" - 11/32" standard 15/64" (6 mm - 9 mm) (standard 6 mm)				
Thread take up lever	Slide type				
Lubrication	Semi-automatic type				
Bed size	20-25/64"x 7" (518 x 177 mm)	33-5/16"x 9-1/16" (846 x 230 mm)	43-5/16"x 9-1/16" (1,100 x 230 mm)	33-5/16"x 9-1/16" (846 x 230 mm)	43-5/16"x 9-1/16" (1,100 x 230 mm)
Working space	10"x 6-1/32" (254 x 153 mm)	20"x 6-1/32" (508 x 153 mm)	30"x 6-1/32" (762 x 153 mm)	20"x 6-1/32" (508 x 153 mm)	30"x 6-1/32" (762 x 153 mm)
Motor	Clutch motor			AC Servo motor	

NOTE (1) Speed depends on threads, materials and type of operation  
(2) Specifications subject to change without notice

## Available needle gauge size

Variety	Available needle gauge size range
28BL-10	3/16"(4.8 mm) - 1-3/4"(44.5 mm) standard 3/4"(19.1 mm)
28BL-20-1	3/16"(4.8 mm) - 2-1/2"(63.5 mm) standard 3/4"(19.1 mm)
28BL-30-1	3/16"(4.8 mm) - 2-1/2"(63.5 mm) standard 3/4"(19.1 mm)
28BLC-20	3/16"(4.8 mm) - 2"(50.8 mm) standard 3/4"(19.1 mm)
28BLC-30	3/16"(4.8 mm) - 2"(50.8 mm) standard 3/4"(19.1 mm)



**SEIKO SEWING MACHINE CO., LTD.**

2-13-6, Sakaecho, Funabashi-shi  
Chiba Prefecture, 273-0018, Japan

Phone : +81-47-420-3561 (Overseas dept.)

Fax : +81-47-420-3560

E-mail : export@seiko-sewing.co.jp

Printed in Japan 2006.06

<http://www.seiko-sewing.co.jp/>